



LUXAIRTM
EXTRACTION WITH ATTRACTION

LA-FLT



Reducer Collar reduces the motor exhaust from 150mm to 125mm if required (Already supplied in box)

Please note this hood must be installed on a minimum of 125mm Ducting

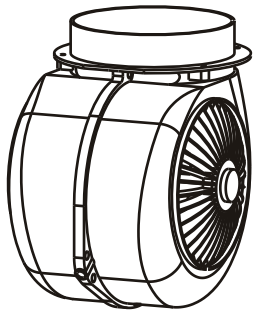

Spare Motor 680 m³/hr
- Fits Models 60cm - 90cm

Spare Motor 980 m³/hr
- Fits Models 100cm - 110cm

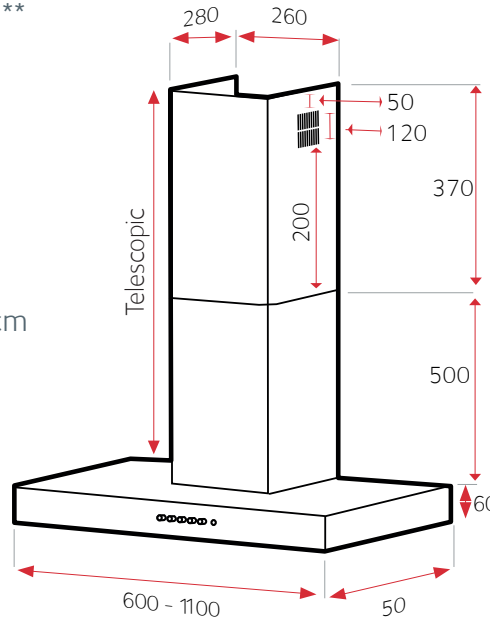

Replacement Switch 2
(Timer Switch)

**Please note on models pre 2012, switch unit is hard wired to the motor. All current models have a plug fitted to both the

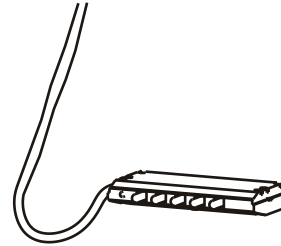

Transformer 1 - 60cm - 90cm
Transformer 2 - 100cm - 110cm

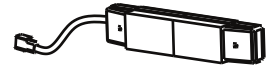

-2x Halogen Fittings 60cm - 90cm
-4x Halogen Fittings 100cm - 110cm
Please note we have 2 different fittings, Polished and Stainless Steel

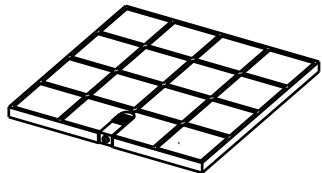

1x Charcoal Filter Square 3

Please note this filter fits directly under the motor. A screw fixing is located behind the metal grease filters

Mesh Grills (current Models)

LA-60-FLT-BLK	2	337x260
LA-70-FLT-BLK	2	323x338
LA-80-FLT-BLK	3	337x260
LA-90-FLT-BLK	3	338x272
LA-100-FLT-BLK	4	337x260
LA-110-FLT-BLK	4	337x260

Please note you must measure your mesh grill size. Older models will have different sizes to current models

