



LUXAIR™
EXTRACTION WITH ATTRACTION

LA-COSMIC-CEILING



Reducer Collar reduces the motor exhaust from 150mm to 125mm if required (Already supplied in box)

Please note this hood must be installed on a minimum of 125mm ducting. We highly advise 150mm ducting

Spare Motor 950 m³/hr
- New 'A' Rated Energy Efficient Motor

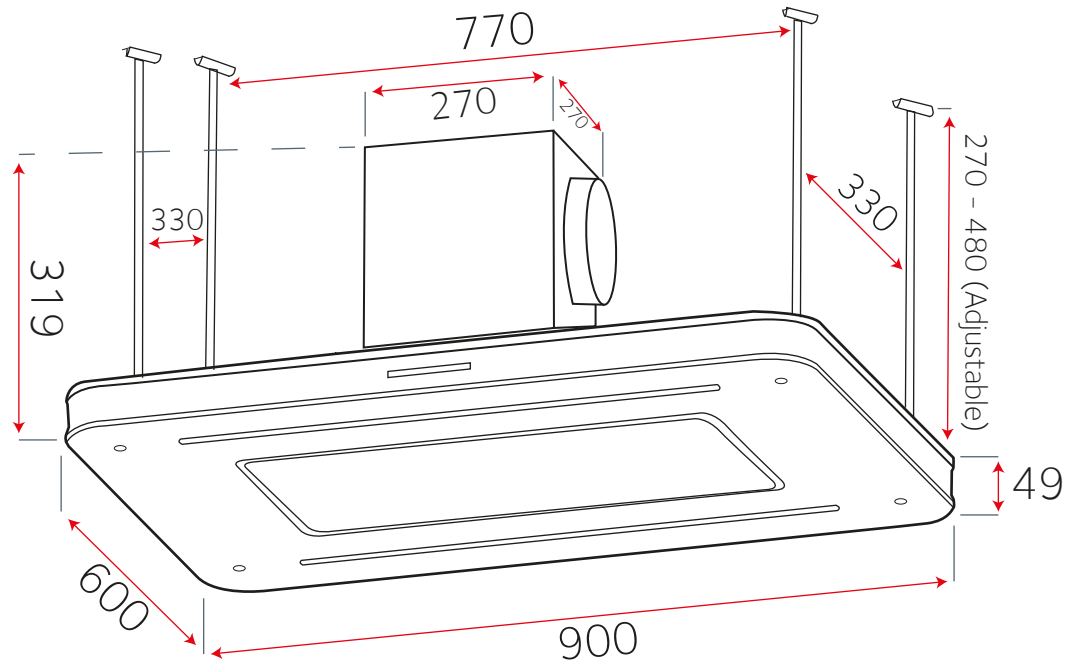

Mesh Grills (current Models)

LA-COSMIC-CEILING x1 260x330
(All Models)

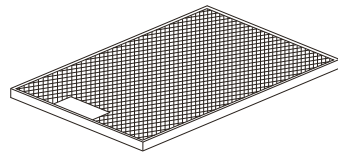

Please note you must measure your mesh grill size. Older models will have different sizes to current models

- 2x 7w LED Strips

