



LUXAIRTM
EXTRACTION WITH ATTRACTION

LA-NEPTUNE



Reducer Collar reduces the motor exhaust from 150mm to 125mm if required (Already supplied in box)

Please note this hood must be installed on a minimum of 125mm Ducting

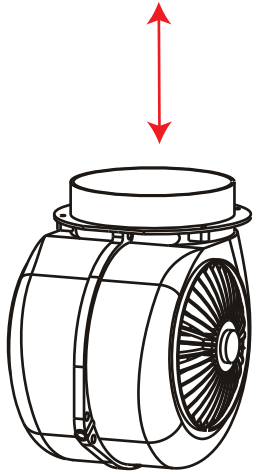

Spare Motor 950 m³/hr
- New 'A' Rated Energy Efficient Motor

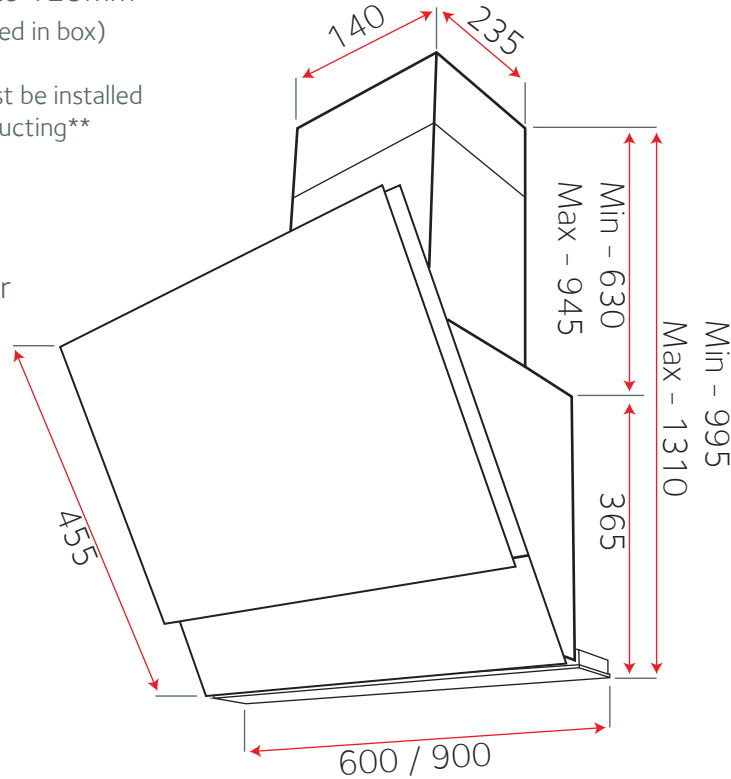

Replacement Switch
- Touch Sensitive

Please contact Luxair for further information

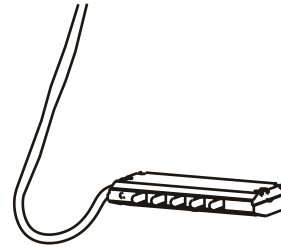

- 1x (6x 1w) LED Lighting Bar

Please contact Luxair for further information

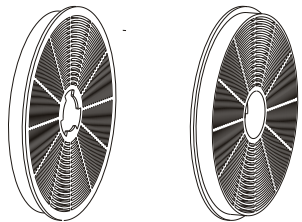
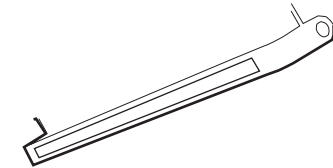

2x Charcoal Filter Round 5

(2 Filters Per Pack, 1 either side of Motor)

Mesh Grills (current Models)

LA-NEPTUNE x2 222x250
(All Models)

Please note you must measure your mesh grill size. Older models will have different sizes to current models

