



# 2 Way Signal Booster with IR Bypass

27822BMR  
User Guide



DigiLink

## Introduction

Congratulations on the purchase of your new SLX Booster. SLX is renowned for producing high quality electrical accessories and signal distribution products. SLX Boosters have a number of features that assist quality distribution of your TV and/or Radio signals around your home, including:

- More efficient Switch-Mode Power Supply - these run cooler saving energy whilst also making them safer in your home
- Improved gain flatness delivering a better balance across the performance range
- Lower noise figure for optimum picture and sound quality
- Greater signal handling capacity to cope with more channels
- Coaxial connectors - simple to plug in to standard aerial connections

We are sure you will enjoy using your SLX Booster, it's easy to install and incorporates the latest technology for energy efficient, long-term, continuous use.

If you have any queries please get in touch with our technical department at [www.slxtechnology.com/support](http://www.slxtechnology.com/support)

## Additional Features

SLX Bypass boosters have an IR bypass circuit and are DigiLink compatible, which means you have the option to control a digital satellite receiver via a Link-eye in another room using the original or a compatible remote control.

SLX Bypass boosters provide 9V DC on every outlet to power a Link-eye but also have short-circuit protection to prevent overload. If the booster detects a short-circuit it will only shut down the power on the outlet with the short, all other outlets will continue to function as normal.

**Please Note: To view output from the satellite RF2 output you will need a TV with an analogue tuner.**

All SLX boosters comply with RED (The Radio Equipment Directive 2014/53/EU).



## General Safety Precautions

### To Prevent Overheating

The recommended clearances and other precautions given in these instructions must be observed to prevent overheating. In addition, units should not be positioned where they are likely to become covered by curtains, fabric or insulating material. The amp should not be left resting on a carpet.

### Other precautions

These appliances are not waterproof, they are intended for indoor use only and must not be positioned where they could be exposed to dripping or splashing water. Objects containing liquids should not be placed on or near the amplifier.

To prevent fire, make sure the unit and attached cabling is installed well away from naked flames and other heat sources.

### Mains Plug

Your amplifier is supplied with a standard mains plug already fitted, if you need to change the plug use a competent professional (ELECTSA or NICEIC) to make the connection. If you need to change the fuse use a 3 Amp fuse to BS1362 carrying the ASTA or BSI approved mark and refit the plastic fuse carrier.

## Before Installing Please Note

### Applications

SLx DigiLink Boosters are suitable for digital TV signal distribution Ch21-60. If you are affected by 4G interference in your area you may need a Ch60 filter (currently available from at800 free of charge).

### Installation

Important note: attention is drawn to the General Safety Precautions Panel above which contains advice on safe installation and operation of these products.

### Location

Choose a location for the booster from which it is convenient to run cables from the antennas and to the system outlets. Typical examples of suitable locations are a loft space or a cupboard. In weak signal areas it is best to keep the aerial cables as short as possible. Select a cool, dry location to install the amplifier. This means a location where the ambient temperature will remain between -10°C and +40°C, and which is free from risk of dripping or splashing water. The fixing location should allow adequate access to the equipment for wiring and maintenance. Clearance of at least 25mm should be allowed around the left hand side and top of the unit for ventilation. More clearance will be needed on the other sides to allow access for cables.

### Fixing

The booster should be fixed to a wall or other suitable hard surface using the keyhole slots on the back of the housing and suitable screws and wall plugs, a template is provided on page 6. The booster should not be left supported by its own wiring, nor should it be left resting on a carpet or other insulating and/or inflammable surfaces.

### Signal Connections

Input and output signal connections are made using IEC coax connectors. Good quality plugs and digital quality double screened coaxial cable should be used to ensure optimum performance from your booster.

### Using the Booster with a Sky™ Digibox

1. When using this booster with a Sky Digibox, the booster must be fed from the RF OUT-2 socket of the Digibox. However if the RF Channel is set to 59 or above (68 is usually the default channel) you will need to reset it to a channel from 21-58 in the Digibox Setup Menu.
2. Later Digibox models such as the Sky+HD 2TB are not fitted with an RF OUT2 output and you will need an I/O converter such as the Labgear MRX600K to distribute signals from the Digibox to other TVs.
3. To view satellite RF2 output TVs require an analogue tuner.

## Installing your Booster - For aerial signal distribution:

1. Connect your UHF aerial downlead to the UHF socket and connect your FM/DAB aerial downlead (if applicable) to the FM socket on the amplifier.
2. Connect your TVs and DAB/FM tuners to any of the booster's TV sockets in any combination.

### Please Note:

If your TV does not have a built-in Freeview™ receiver you will need to connect your TV to the amplifier via a Freeview™ set top box.

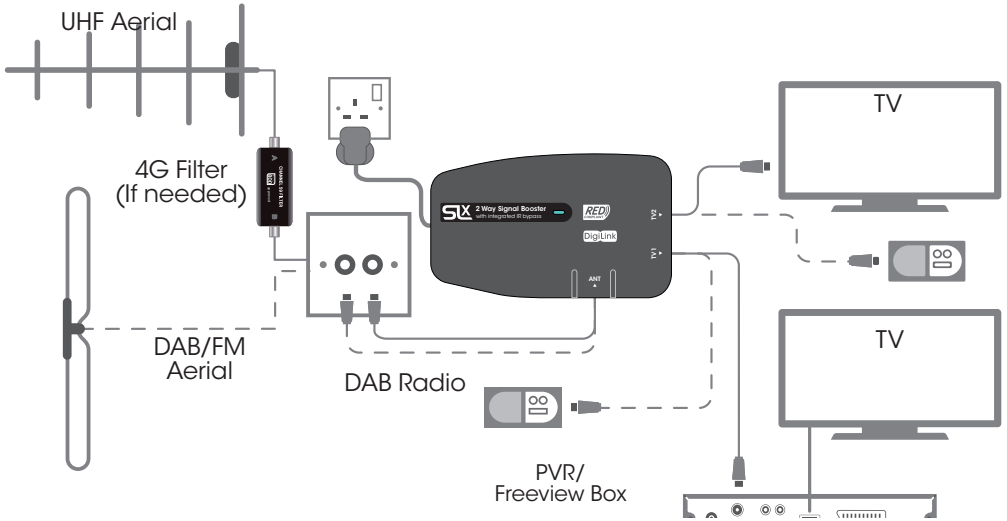

## For signal distribution from a Satellite Receiver

**Please Note:** To view output from the satellite RF2 output you will need a TV with an analogue tuner.

1. Connect your UHF aerial downlead to the aerial input on your Satellite Receiver and connect your FM aerial downlead (if applicable) to the FM socket on the booster.
2. Connect an aerial fly-lead from the RF2 output on the Satellite Receiver to the UHF input on the booster.
3. Connect your TVs and FM tuners to any of the booster's TV sockets in any combination. Once connected, you can tune each television to digital terrestrial channels\* and a channel for satellite viewing.

**Note:** Only one satellite channel can be viewed at any one time without the use of additional satellite receivers and subscriptions.

**Note:** To operate your digital satellite receiver from one of the connected TVs you will now need to install a Link device such as the SLX Link.

**Note:** To view digital terrestrial channels an aerial must be connected to the Aerial IN socket on the satellite. Also connected TVs must have a built-in Freeview™ receiver or be connected to the booster via a Freeview™ set top box.

## Signal distribution from a Satellite Receiver

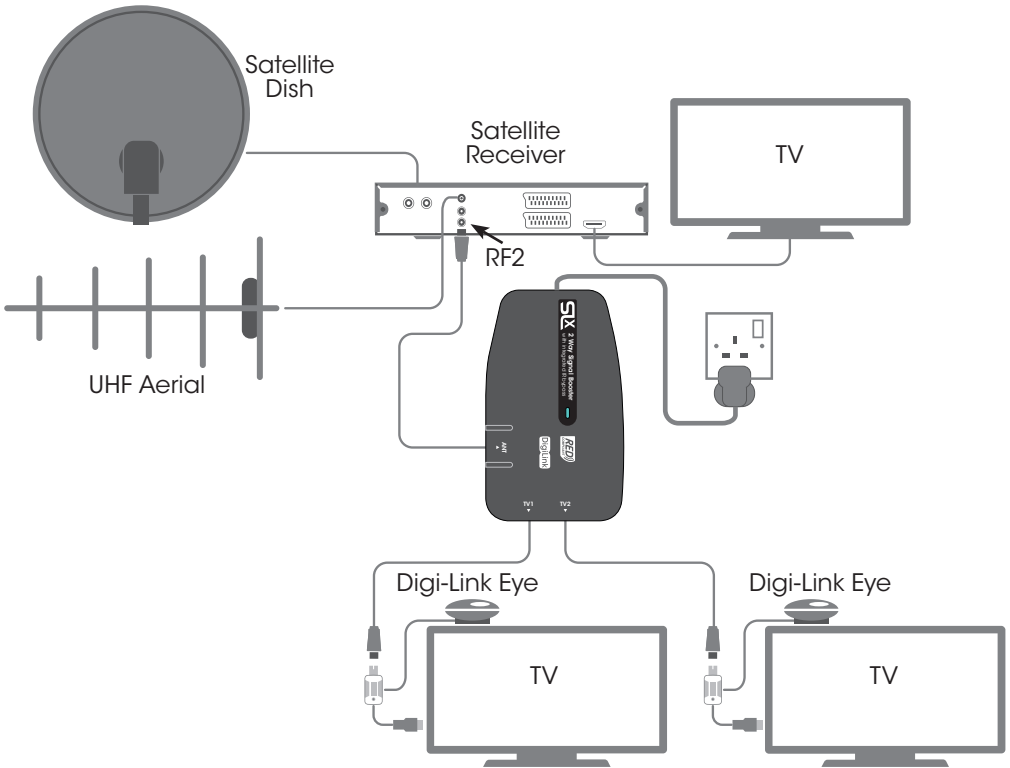

### Resetting the RF Channel on a Digibox

1. Switch on your Sky™/Sky+™/ Sky+ HD™ receiver and view on your main television.
2. Press the SERVICES button on your Sky™ remote.
3. Select SYSTEM SETUP option (for SKY+ HD there is no SYSTEM SETUP option press 0 instead).
4. Press the following buttons in sequence: 0, 1, SELECT (for SKY+ HD this is a hidden option and does not appear on screen). You should now see the installers' menu.
5. Select the RF channel number option and key in a new channel number from 21-58 and select 'Power On'. Make a note of the channel number you choose as you may need it when tuning your other TVs.

## Troubleshooting

If you experience reception problems after installing the your booster, please see below:

### No picture or sound

Is the signal reaching your TV? Check:

- Everything, including the booster is switched on
- Coaxial connections are correctly made (no braid or foil touching the inner core)

### Picture or sound breaking up

- Use the best wideband aerial ideally fitted outdoors
- Use good quality coax cable, poorly screened cable can pick up noise
- In some cases too much signal can cause signal break-up which can be solved by fitting an attenuator to the input to the booster

For specific help with digital TV reception problems, visit [www.digitaluk.co.uk](http://www.digitaluk.co.uk) or [www.bbc.co.uk/reception/television/freeview/reception\\_problems](http://www.bbc.co.uk/reception/television/freeview/reception_problems)

### Problems with satellite television

If you are experiencing any problems with your satellite television picture, check that all cables and connectors have been fitted correctly. If the problem persists it is probably due to the dish alignment or a temporary problem with the channel transmissions. Please contact your local satellite dealer if the problem persists.

## Specifications

| Booster             | In | Out | Frequency<br>VHF Signal<br>UHF Signal | Suitable<br>for                   | Gain | Noise<br>Typ. | Isolation<br>Out/Out | Max<br>Output | IR<br>Bypass    | IR Power         |
|---------------------|----|-----|---------------------------------------|-----------------------------------|------|---------------|----------------------|---------------|-----------------|------------------|
| 27822BMR<br>SLx2 IR | 1  | 2   | 87-790MHz                             | FM/DAB/<br>TV Ch21-60<br>Freeview | 17dB | <3dB          | 12dB                 | 94dB $\mu$ V  | 5-30MHz<br>+3dB | 9VDC<br>15mA SSP |

Philex reserve the right to modify their designs or specifications, In the light of future developments, without prior notice. Performance figures quoted are typical and subject to normal manufacturing and service tolerances.

## Technical Support

If you experience problems setting up your aerial, please visit our technical website at [www.slxtechnology.com/support](http://www.slxtechnology.com/support) you can send us a message or **live chat** during office hours.

## Declaration of Conformity

Hereby, Philex declares that this booster/ amplifier for TV broadcast reception in domestic premises is in compliance with the Radio Equipment Directive 2014/53/EU. The full Declaration of Conformity is available by contacting the following internet address: [www.slxtechnology.com/DoC](http://www.slxtechnology.com/DoC)



Standard: EN 303 354  
Product Type: D Signal Distribution Amplifier

Suitable for digital TV signal distribution Ch21-60 from a receiver or from an aerial fitted with a 4G filter in the UK and EIRE.



Waste electrical and electronic products should not be disposed of with household waste. Please recycle where facilities exist. Check with your Local Authority for recycling advice.



## Wall Mounting Drilling Template

