

1

HEATRAE SADIA

Cameo

ELECTRIC SHOWER

INSTALLATION and USER INSTRUCTIONS

ref. 36 00 5804 issue 2 July 01



Model number
Cameo 7.2kW - 95 02 1645

**PLEASE READ AND UNDERSTAND THESE INSTRUCTIONS BEFORE
COMMENCING INSTALLATION**

PLEASE LEAVE THESE INSTRUCTIONS WITH THE USER

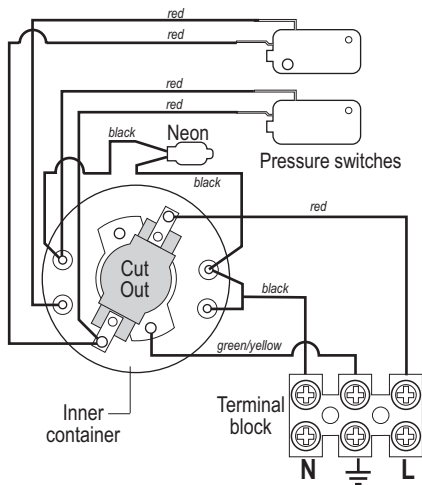
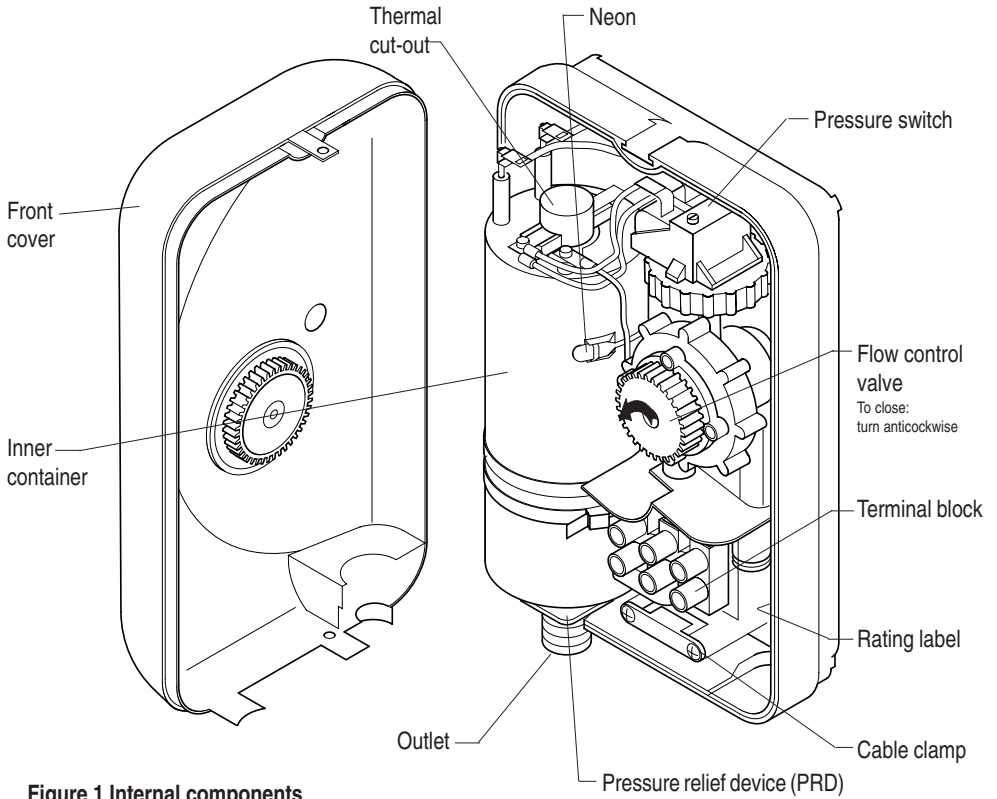

CONTENTS

Internal components	p2
Wiring diagram	p2
Technical specifications	p3
Important information	p4
Siting and plumbing	p5
Things you must do	p5
Electrical installation	p7
Connecting to services	p8
Cable entry	p9
Pipe entry	p9
Plumbing	p10
Fitting the riser rail	p10 & p11
Fitting the wall bracket	p11
Fitting the hose	p12
Electrics	p12
Fitting the cover	p12
Commissioning	p13
Guarantee & service policy	p13
Environmental information	p13
User information	p14
Fault finding	p15 & p16
Address and phone numbers	p16

1 TECHNICAL SPECIFICATIONS

1.1 CONNECTIONS

Inlet connection -15mm ext. diameter
(copper or 'Speedfit'
Stem Elbow)

Water entry point - bottom and rear

Cable entry point - bottom and rear

1.2 ELECTRICAL

Nominal Power Rating

Model	240V	230V
7.2kW	7.2kW 30A	6.6kW 28.75A

1.3 MATERIALS

Backplate, cover
and control knob -High Impact
Polystyrene

Elements -Copper sheathed rod
type

1.4 DIMENSIONS

Height - 232mm

Width - 146mm

Depth - 95mm

1.5 STANDARDS AND APPROVALS

Complies with the requirements of
EN 60335-2-35.

British Electrotechnical Approvals Board
(BEAB) approved.

Complies with European Community
Directives (CE).

2 IMPORTANT INFORMATION

2.1 Your shower is designed and tested to the very highest standards and complies fully with all of the relevant British and European standards for safety and reliability. The shower is manufactured in a BSEN ISO 9002 - registered factory - your assurance of a quality product.

2.2 To ensure correct use and maintenance of the shower, please read and adhere to the following warnings and guidelines.

FOR INSTALLERS

2.3 Do not attempt any of the electrical or plumbing work necessary to install this product unless you have good practical experience and adequate understanding of the IEE Wiring Regulations and Water Regulations.

2.4 WARNING: THIS APPLIANCE MUST BE EARTHED.

2.5 Before removing the front cover, always ensure your shower heater is isolated from the electrical mains.

2.6 This product is splash proof and is approved for use in shower cubicles and over baths. However, **do not install the shower heater in a position where the handset, in its normally-parked position, will consistently direct the spray over it.**

FOR USERS

2.7 If water emerges from anywhere other than the spray head outlets, do not use your shower, **TURN OFF ELECTRICITY** and refer to the Fault Finding section.

2.8 IT IS IMPORTANT TO CLEAN THE SPRAY PLATE OR SPRAY ASSEMBLY REGULARLY, particularly in hard water areas, where this may be necessary as often as once a week. Failure to do so will affect the performance of the shower and in extreme cases may cause the pressure relief device (PRD) to operate - see Fig. 1 and Fault Finding (p16).

Refer to the user instructions for handset maintenance information - see 8.3.

2.9 The shower heater outlet, hose and handset act as a vent. They must not be blocked, obstructed, or have connected to them any fitting not approved by the manufacturers. The use of unapproved accessories may affect the performance and safety of the unit.

2.10 WARNING! DO NOT USE the shower if the HOSE IS DAMAGED in any way; for instance if the outer covering has parted to reveal the inner tube.

A damaged hose can suddenly restrict the flow and result in extremely hot water being emitted from the showerhead.

A damaged hose could completely block the outlet of the shower; the resulting increase in pressure could burst a weakened or damaged hose.

2.11 Do not install the shower in a situation where the water in it could freeze. Any damage caused by freezing will not be covered by the guarantee.

If the shower is suspected of being frozen, SWITCH OFF IMMEDIATELY. Refer to Fault Finding (p15)

2.12 Do not leave the infirm, disabled users, or young children unattended in the shower.

2.13 Before stepping into the shower, always test the temperature of the spray with your hand.

2.14 Switch off at the isolating switch after showering.

2.15 As with all electrical appliances, it is advisable to have your shower and installation checked at least every two years by a competent electrician, to ensure that there is no deterioration due to age and usage.

3 SITING AND PLUMBING

3.1 Spend some time planning exactly where to site the shower heater and riser rail. Bear in mind the height of people who will be using it.

THINGS YOU MUST DO

3.2 Check that the **water pressure** to the shower is adequate. If in doubt, consult a competent plumber.

Maximum 0.7MPa (7bar - 100 psi)

Minimum 0.1MPa (1bar - 14.5psi)

The use of other services connected to the water pipe supplying the shower heater may cause the water pressure to drop below the minimum. Therefore this should be taken into account.

The following conversions may be useful:

1 bar = 14.5 lbf/in² = 33.3 ft head of water.

1 lbf/in² = 2.3 ft head.

3.3 Electric shower heaters are normally plumbed into the mains water (except for special low pressure versions). However, the shower heater may be fed from a storage tank where there is a sufficient head of water, i.e. over 10m.

3.4 Mount the shower heater on a flat vertical wall with the outlet, to which the hose is connected, pointing downwards.

3.5 DO NOT place the shower heater where it will be in the direct spray from a normally-parked handset.

3.6 Allow room around the shower heater for removal of the front cover - see Fig. 7 & 8.

3.7 Position the riser rail close to the heater, not necessarily on the same wall (but bear in mind paragraph 3.5) so that in the highest parked position, the handset is not more than 610mm above the bottom of the heater and in its lowest position it is no lower than 305mm below the heater - see Fig. 3.

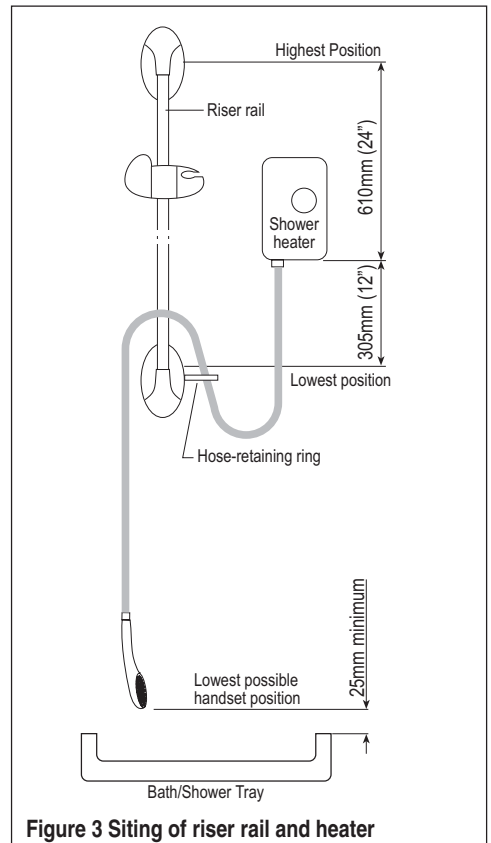

Figure 3 Siting of riser rail and heater

3.8 If the handset can reach to within 25mm (1") of the spillover level of the bath, shower tray, wash basin, WC or bidet, then to prevent the possibility of back-siphonage of used water (Water Regulations Guide G15.14/R15.14) you must either:

1. Install a hose-restraining ring - see Fig. 3.
2. Fit a double-check valve in the pipe work to the shower.

3.9 Decide from which direction your inlet pipe will enter the shower heater. There is a choice of entry from bottom or rear - see Fig. 12. It is advised to use rear entry when possible, as this gives a neater installation.

3.10 Ensure there are no services such as gas, water pipes, electrical or telephone cables beneath the surface of the wall before drilling. Special hand-held testers are available from hardware stores.

3.11 The water connection to the shower heater should be made using standard 15mm outside diameter copper or a 'Speedfit Stem Elbow'. The ends of the pipe should be cut square and be free from internal and external burrs and deep scratches.

3.12 Cut all necessary pipe work to length with a pipe cutter and not a hacksaw, to minimise swarf - see Fig. 4.

3.13 A Water Regulations Advisory Service listed servicing valve should be fitted in the water supply pipe to the shower. This is to allow the shower heater to be serviced without turning off the water supply to other appliances.

3.14 DO NOT use plumber's paste on any joints as this may damage the shower.

3.15 DO NOT use a blow-torch or other form of heat close to the shower heater as this may damage the non-metallic parts.

3.16 DO NOT use excessive force, but do ensure adequate support, when making connections.

3.17 Before making the final water connections to the shower heater, the pipe-work **MUST BE FLUSHED THOROUGHLY** to remove brick dust, swarf etc. which could severely damage the shower itself - see Fig. 5.

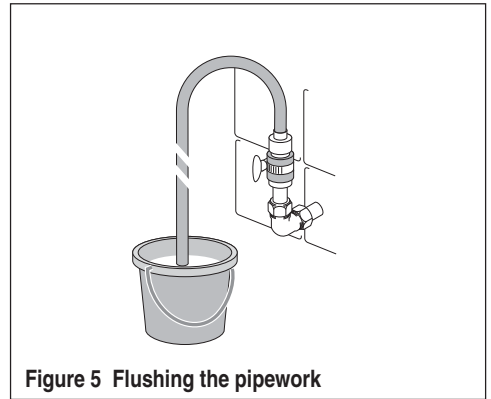

Figure 5 Flushing the pipework

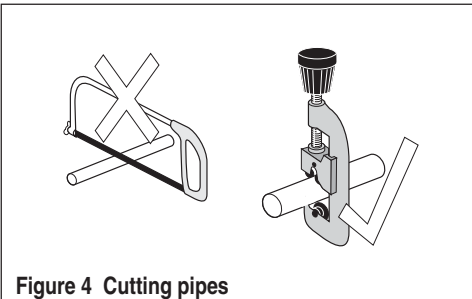

Figure 4 Cutting pipes

4 ELECTRICAL INSTALLATION

WARNING

4.1 This appliance must be earthed.

4.2 The installation, supply cable and circuit protection must conform to BS7671 'Requirements for electrical installations' (IEE Wiring Regulations).

The following notes are for guidance only:

4.3 The shower heater must only be connected to a 230/240V ac supply.

4.4 Before making any electrical connections within the installation, make sure that no terminal is live. If in doubt, SWITCH OFF the whole installation at the consumer unit or switch fuse (where fitted).

4.5 The shower heater must be connected to its own independent electrical circuit. It **MUST NOT** be connected to a ring main, spur, socket outlet, or lighting circuit, otherwise the circuit will overheat - see Fig. 6.

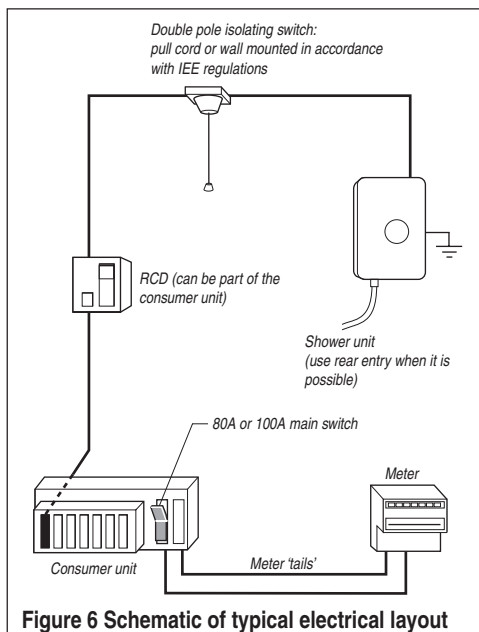

4.6 Check that your consumer unit (main fuse box):

1. has a main switch rating of 80A or above and
2. has a spare fuse way which will take the fuse/mcb you need to fit - see Fig. 6.

If so, you can wire the shower direct to the spare fuse of your consumer unit - see Fig. 6.

Note that not all consumer units accept a 35/40/45A sized fuse.

4.7 If 4.6, 1 and 2 are not achievable, the installation is not straightforward, since it could involve installing a new consumer unit to serve the whole house or just the shower. You will need to call in your Regional Electricity Company to check the circuit and make the connections to the meter or service connector block. They will also check the earth bonding of items in the bathroom.

4.8 All exposed metallic parts in the bathroom must be bonded together using cable of at least 4mm² CSA (cross sectional area). These parts include metal baths, radiators, water pipes (including the feed to the shower), taps and waste fittings.

4.9 For all installation arrangements work back from the shower to the consumer unit. Before making the final connections, check the circuit for continuity and insulation resistance.

4.10 It is recommended that a **residual current device (rcd)**, formerly known as an earth leakage circuit breaker (elcb), with a tripping current of 30mA, is incorporated in the circuit. This removes the need to check your earth loop impedance.

4.11 A double-pole isolating switch rated at 30A or greater, with a contact separation of at least 3mm in each pole, must be incorporated in the circuit. This must have a mechanical indicator showing when the contacts are open. An indicator lamp alone is not sufficient. It is recommended that only cord operated switches are fitted in bathrooms. The switch must be located so that the body is more than 2.25m above the inside of the bottom of the bath or shower tray and more than 600mm outside the showering area. It should be readily accessible (you should switch off the shower at the isolating switch after showering).

4.12 Choosing cable and fuse sizes

The nominal current of your shower is 30A at 240V - see 1.2. The current rating of your cable must be at least that of the shower itself. Use Table 1 to choose a fuse or mcb. **DO NOT** use rewirable fuses.

If the cable is to be:-

1. bunched with others
2. in an ambient of above 30°C
3. in an insulating wall or within thermal insulation, e.g. loft insulation
- 4 any other unusual situation

the current rating will be reduced and it will be necessary to use a larger size of cable.

IF IN DOUBT **ALWAYS** SEEK ADVICE FROM A COMPETENT ELECTRICIAN.

5 CONNECTING TO SERVICES

PREPARATION

5.1 Remove the fixing screw which holds the front cover onto the backplate of the shower heater. Carefully remove the cover.

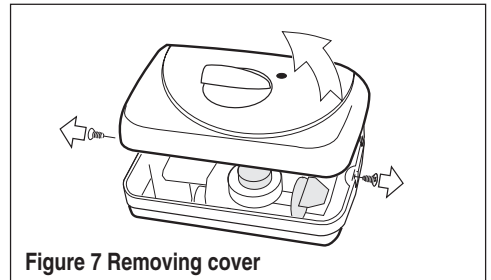

Figure 7 Removing cover

5.2 The control knob is an integral part of the cover - do not attempt to remove it.

5.3 The unit must be mounted on a flat surface, which covers the full width and length of the backplate. It is important that the wall surface is flat otherwise difficulty may be encountered when fitting the cover.

TABLE 1

(Values are in Amperes)

	4mm ² cable			6mm ² cable		
	Clipped direct ¹	Enclosed in trunking ²	Enclosed in insulating wall ³	Clipped direct ¹	Enclosed in trunking ²	Enclosed in insulating wall ³
Cable rating	36	30	N/A	46	38	32
Fuse rating	30	30	N/A	30	30	30
MCB rating	32	N/A	N/A	32	32	32

1. Clipped direct means cable clipped onto a wall without a covering, or embedded directly in masonry, concrete, plaster etc.
2. Enclosed in trunking means cable is on its own in a plastic or metal conduit fixed to the wall or ceiling.
3. Enclosed in insulating wall, where cable is enclosed in a plastic or metal conduit within a thermally insulated wall where heat can only escape through the insulating material.

5.4 DO NOT fit the shower to the wall and tile up to the case. It must be fitted **on to a finished flat and even wall surface**. This allows removal for servicing.

5.5 You should leave at least 130mm around the shower heater for fitting the front cover in place and for fitting the cover-fixing screws - see Fig. 8.

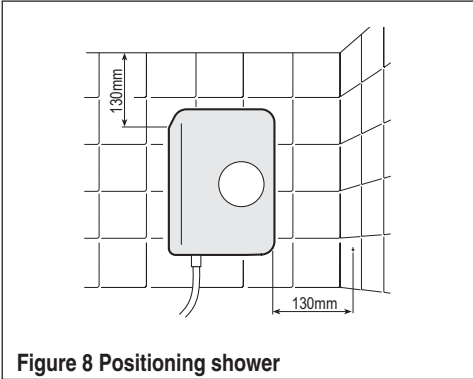

Figure 8 Positioning shower

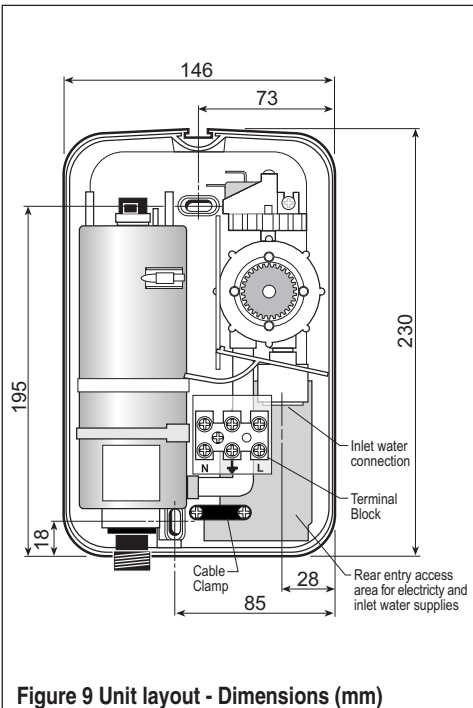

Figure 9 Unit layout - Dimensions (mm)

CABLE ENTRY

5.6 Cable entry can be from the rear (preferred) or from the bottom. The backplate has cut out positions to suit 2 sizes of cable. When opting for bottom entry make cut out to suit cable before fitting backplate to the wall - see Fig. 10.

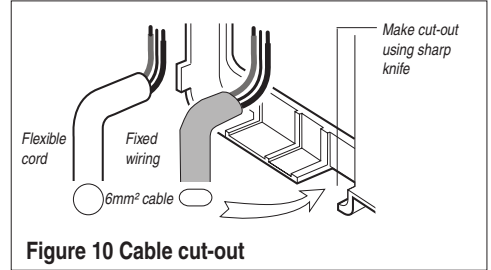

Figure 10 Cable cut-out

PIPE ENTRY

5.7 Plumbing entry can be from the rear (preferred) or from the bottom. The backplate has a cut out position to suit 15mm pipe. When opting for bottom entry make cut out before fitting backplate to the wall - see Fig. 11.

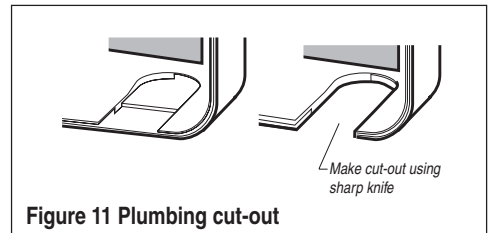

Figure 11 Plumbing cut-out

5.8 Fix the shower heater loosely to the wall. The wallplugs provided are suitable for most brick walls (use a 6.5mm diameter masonry drill), but if your wall is plasterboard or soft building block, you should use special wallplugs and an appropriate drill, obtainable from most hardware stores.

PLUMBING

5.9 Decide where to connect to the water mains for your feed to the shower. Ensure that the pipe you have selected is not a gas pipe (they can look similar) or a hot water pipe or from a cold water storage tank (unless you have sufficient head - see 3.2 & 3.3).

5.10 Cut the necessary pipe work to length, assemble and offer up to the installation before making any soldered joints. Ensure that the pipe is the correct length, as shortening it can be difficult once joints have been made.

5.11 Carry out any cutting with pipe cutters to minimise swarf.

5.12 Remember to incorporate a servicing valve and, if required, a double check valve - see 3.8 & 3.13.

5.13 Locate your stop cock and turn off the water supply. Check that the pipe you intend tapping into no longer carries water, by opening a tap that the pipe supplies.

5.14 Make your connection to the pipe. If it is on a low-lying loop there may be some water left in the pipe, so be prepared for some flow of water. Make all joints except that to the shower heater before flushing.

5.15 It is essential to flush the pipe in order to clear debris, particles or solder and swarf prior to connecting to the shower - see Fig. 5.

5.16 Turn the water off after flushing, either at the stop cock or by using your servicing valve.

5.17 Connect the cold water supply pipe to the inlet of the shower, this is a push fit connection - see Fig. 12.

5.18 Fit top and bottom screws and secure the backplate to the wall ensuring that it is level.

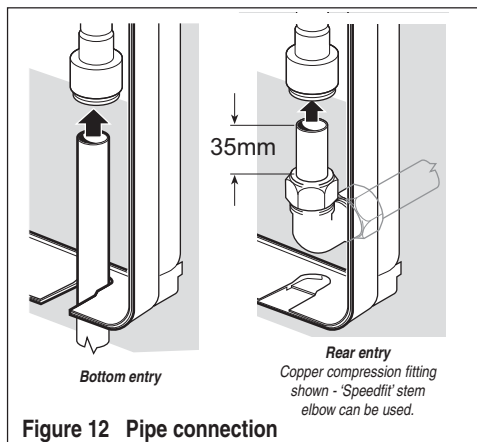
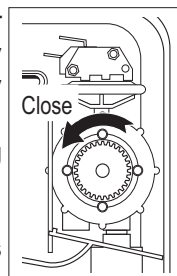

Figure 12 Pipe connection

5.19 Close the shower flow control valve by turning the gear fully anticlockwise.

5.20 Turn the servicing stop valve on slowly and check for leaks in all pipework and rectify as necessary.



5.21 Turn off the servicing valve.

FITTING THE RISER RAIL

5.22 Remove the covers from the two end brackets.

5.23 Locate the riser rail into the two end brackets and decide on the best position of the rail in relation to the heater unit - see 3.7.

5.24 Mark the positions of the top screw holes and remove the riser rail from the wall. Drill and plug the screw holes.

5.25 Secure the top end bracket using the screws provided.

5.26 Fit the handset holder onto the riser rail and slot the rail into bottom end bracket.

5.27 Slot riser rail into top end bracket and mark position of bottom screw holes. Remove bottom end bracket and riser rail sub-assembly, drill and plug holes, then replace and screw to wall.

5.28 Clip the finishing covers onto the top and bottom end brackets.

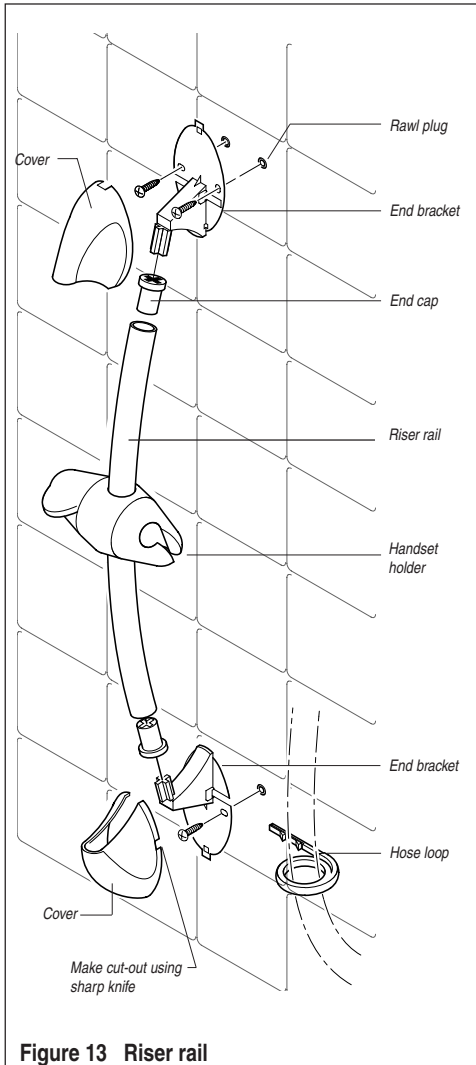

FITTING THE WALL BRACKET

5.29 Remove plastic wall fixing plate from the wall bracket. Position the fixing plate on the wall and make a mark with a pencil through each of the two holes.

5.30 Drill and plug the holes, then screw the fixing plate to the wall.

5.31 Using your fingers, pull forward the flexible “bellows” of the wall bracket to reveal the end that fixes onto the wall plate.

5.32 Slide the wall bracket onto the rails on the fixing plate and press downwards until it fits into place.

5.33 Replace “bellows” to cover wall bracket.

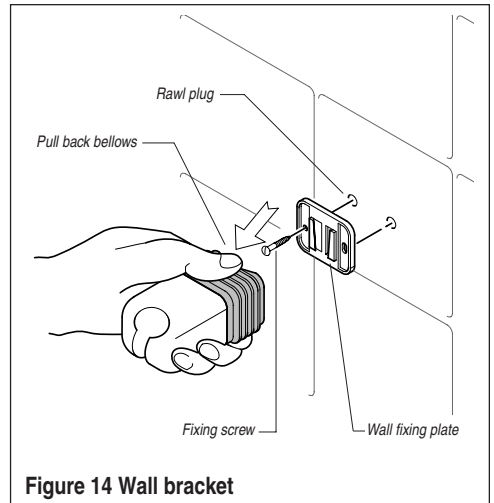

FITTING THE HOSE

5.34 Secure one end of the hose to the handset and screw the other end of the hose to the shower heater outlet. Ensure that the black sealing washers are fitted.

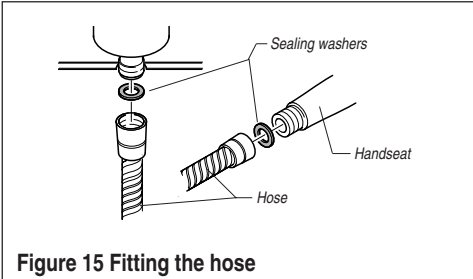

Figure 15 Fitting the hose

ELECTRICS

5.35 Design your system as outlined on pages 7 & 8. Lay the cable in your chosen route, ensuring that you have ample length.

5.36 Leave the connection to the consumer unit or switch-fuse until last.

5.37 Remember, when working on electrical components, ensure they are **not** switched on electrically. If in any doubt, switch off at your main switch at the fuse board or consumer unit.

5.38 The cable entry should have been decided before fitting the backplate - see 5.6.

5.39 Remove the screws and clamping bar from the cable clamp - see Fig.16.

5.40 Feed the cable in the backplate (unscrew backplate for easy feeding if necessary).

5.41 Strip the outer sheath of the cable to a point about 5mm above the clamp, **thus ensuring that the cable is clamped across its outer sheath.**

5.42 Strip the insulation from the cores and make connections - see Fig. 16.

5.43 Make sure that all the terminal block screws are tightened **FIRMLY**.

5.44 Refit the clamp bar (for a 10mm² cable, the clamp bar is not required). If cable enters from the rear **DO NOT** use the cable clamp.

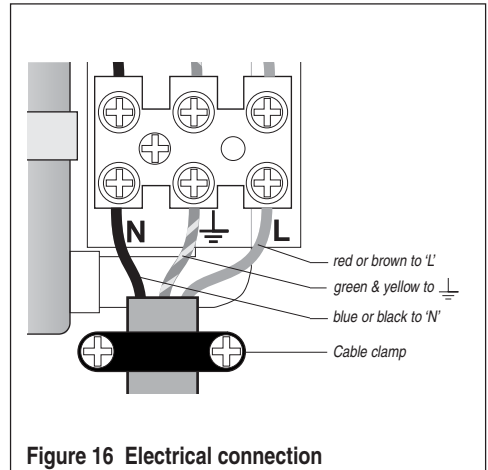

Figure 16 Electrical connection

FITTING THE COVER

5.45 The hose must be fitted - see 5.34.

5.46 Check that the flow control valve is fully closed by turning the gear fully anticlockwise - see 5.19.

5.47 Turn control knob until the indicator is between 'START' and 'STOP'.

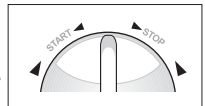

5.48 Place the cover onto the backplate.

5.49 Secure the cover to backplate using screws provided.

COMMISSIONING

NOTE: The first operation of the shower is intended to ensure the heater unit contains water before the unit is switched on.

5.50 Secure the handset on the riser rail, in a position where it can spray safely.

5.51 Before turning on the electricity and mains water to the shower, ensure the control knob is turned fully clockwise.

5.52 Turn on the main water supply at the servicing stop valve and slowly turn the control knob anticlockwise (it will take approximately 30 seconds for a smooth flow of water to be obtained whilst any air is being dispersed from the shower).

5.53 Stop the water flow by rotating the control knob clockwise.

5.54 Turn on the electrical supply at the isolating switch.

5.55 Rotate the control knob half a turn anticlockwise. After approximately 15 seconds, the water will start to heat.

5.56 To obtain warmer water turn the control knob clockwise and for cooler water turn anticlockwise.

5.57 Shut off the shower by turning the control knob clockwise. The unit is now ready to use.

6 GUARANTEE & SERVICE POLICY

This product is guaranteed against faulty materials and manufacture for a period of 2 years from the date of purchase provided that:-

6.1 The unit has been installed in accordance with the Installation and User Instructions and all relevant Codes of Practice and Regulations in force at the time of installation and that all necessary controls and safety valves have been fitted correctly.

6.2 Any valves and controls are of Heatrae Sadia recommended type and specification.

6.3 The unit has not been modified or tampered with in any way and has been regularly maintained as detailed in the Installation and User Instructions.

6.4 The unit has been used only for heating potable water.

The unit is not guaranteed against damage by frost and the inner container with integral heating element is not guaranteed against excessive scale build-up.

This guarantee in no way affects the statutory rights of the consumer.

The policy of Heatrae Sadia is one of continuous product development and, as such, we reserve the right to change specifications without notice.

7 ENVIRONMENTAL INFORMATION

Heatrae Sadia products are manufactured from many recyclable materials. At the end of their useful life they should be disposed of at a Local Authority Recycling Centre in order to realise the full environmental benefits.

8 USER INFORMATION

8.1 To turn on and set temperature:

1. Turn on your isolating switch.
2. Turn water control knob anti-clockwise to allow water to flow until "power on" neon illuminates; the shower is then heating.

WARMER - DECREASE FLOW - TURN KNOB CLOCKWISE

COOLER - INCREASE FLOW - TURN KNOB ANTI-CLOCKWISE

Make adjustments carefully. Give the shower a few seconds after each adjustment to stabilise, then check the temperature by hand before stepping into the shower.

A cold shower can be obtained simply by leaving your isolating switch off and operating the water control knob.

8.2 To turn off:

1. Turn the water control knob fully clockwise.
2. Turn off your isolating switch.

Maintenance

8.3 Cleaning the Handset:

To obtain the best performance from your shower, the handset must be cleaned regularly, maybe as often as once a week in hard water areas.

This is because the fine outlet holes can become blocked with scale and this will affect the pattern of the spray and cause the heater to perform poorly.

The easiest and most effective method of cleaning your handset, regardless of which type you have with your shower, is to soak it in a proprietary descalant or vinegar. For best results the handset should be left to soak overnight.

With handset types 1 & 2, the spray plate can be easily unscrewed by hand, should you need to give the handset a quick clean. Use a small stiff brush such as a toothbrush or nailbrush to remove the limescale, before screwing the sprayplate back into the handset.

8.4 Inspection

We recommend that in the interests of safety the shower and its electrical installation is checked by a qualified electrician at least every two years.

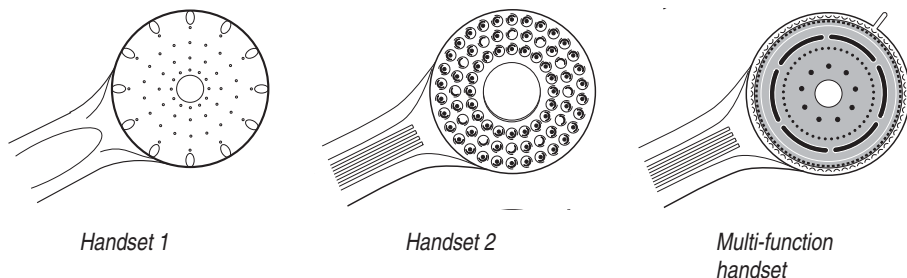

Figure 17 Handsets

9 FAULT FINDING

In the unlikely event of a problem, consult the trouble shooting chart below.

For your particular system follow the suggested remedies in the order given. If you are unable to remedy the problem, **CONTACT YOUR INSTALLER IN THE FIRST INSTANCE**. Do not attempt any electrical or plumbing work unless you are competent to do so.

SYMPTOM	POSSIBLE CAUSE	REMEDY
1. No flow or not enough flow.	A. Water control knob is turned fully clockwise.	Turn water control knob anti-clockwise.
	B. Water turned off at mains or servicing valve.	Ensure water is fully turned on at the mains and at servicing valve in circuit.
	C. SHOWER HEATER SUSPECTED OF BEING FROZEN.	If so, DO NOT USE 1. Switch off immediately at isolating switch. 2. Turn water off at servicing valve (if fitted) or at stop cock. 3. Contact our Service Department.
	D. There may be an outlet blockage.	Disconnect handset from hose and run the shower. 1. If water flows, then handset is blocked with scale or debris. Remember that disturbances to plumbing elsewhere in your house, or in the street, can dislodge debris which can find its way to the shower. Clean the handset and spray rings/plate thoroughly. 2. If the water does not flow, remove hose from the shower outlet. 2a If the water flows then the hose is blocked. This could be due to damage, severe kinking or even an obstruction. Renew the hose. 2b If the water does not flow, there is a blockage in the plumbing to the shower, or the shower itself. Contact our Service Department if the shower is considered to be the problem.
2. Flow adequate but water too cold.	A. Electrical power to the shower heater is off.	Ensure that the electrics to the shower are switched on, and the neon is lit.
	B. Water flow too high.	Reduce the flow by turning the water control knob clockwise slowly. NOTE: If the knob is turned too far clockwise, the safety pressure switch inside the shower will turn off the heating elements. This is apparent when the indicator light on the shower goes out. If this happens, turn the knob anti-clockwise until the light comes on.

SYMPTOM	POSSIBLE CAUSE	
3. Water too hot.	A. Water flow too low.	Increase the flow by turning the water control knob anti-clockwise.
	B. Spray plate blocked with scale or debris.	Clean the handset spray plate.
4. Temperature varies while showering, cycling hot/cold.	A. Pressure switch is operating, normally making a "click" as it does so.	
	B. Input pressure is below 1.0 bar (14.5 psi); flow is not stable.	Ensure that your stop cock and servicing valve are opened fully.
5. "Power on" indicator not lit. Isolating switch "On" but its neon not lit.	A. Cartridge fuse or miniature circuit breaker (mcb) has operated in your fusebox (or consumer unit) or switch fuse.	Switch off shower and isolating switch. Renew fuse or reset the mcb. If they operate a second time, contact a qualified electrician.
	B. Residual current device (rfd) or (earth leakage circuit breaker) has operated.	Follow the same procedure as above. If this has happened with a "split load" consumer unit on initial installation, check that the neutral core of the shower feed cable is connected to the "protected" neutral bar of the unit.
6. Water emerges from bottom of the unit.	PRD has operated	<ol style="list-style-type: none"> 1. Switch off immediately at isolating switch. 2. Turn water off at the servicing valve (if fitted) or stop valve. 3. Contact Heatrae Sadia Service Department.

Due to continuous improvement and updating, specifications may be altered without prior notice.

Heatrae Sadia Heating Ltd, Hurricane Way, Norwich, Norfolk NR6 6EA. www.heatraesadia.com	Service Tel: (01603) 420330 Fax: (01603) 420349 email: service@heatraesadia.com	Sales Tel: (01603) 420110 Fax: (01603) 420149 email: sales@heatraesadia.com