

## Powersaver DUAL Flexi Immersion Controller



### Benefits

The Powersaver Dual bridges the gap between the bulky, aged electro-mechanical immersion controllers and the complicated 'bells & whistles' digital versions.

A table of pre-selectable adjustable programs are offered - covering all of the low rate electricity tariffs, including Economy 7, Economy 10 & Eco 20:20 times. Turn the Installer Switch to the program of choice (refer to Installation and User Instructions). Adjustment is possible to the preset times enabling the program periods to be reduced or cancelled as required. The review button allows ON/OFF times to be checked & there is automatic GMT/BST changeover.

There is a ½ hour, 1 hour & 2 hour boost function with a digital display countdown clock, allowing the user to clearly see boost times. There is also a programmable boost function for further end user convenience; this program is deliberately limited to a maximum of 2 hours, meaning expensive electricity is not being wasted during peak times.

Suitable for Single, Twin & Dual element immersion heaters.

### Features

- Suitable for single, dual and twin immersion elements
- Direct upgrade to Horstmann E7 & E7Q and Sangamo Q7 controllers
- Pre-set programs for use with low rate tariffs
- 24 hour electronic timer

#### Single

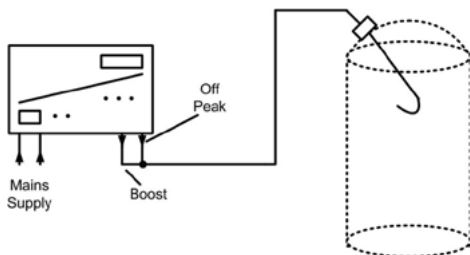

#### Dual

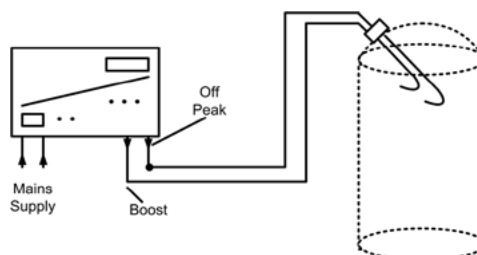

#### Twin

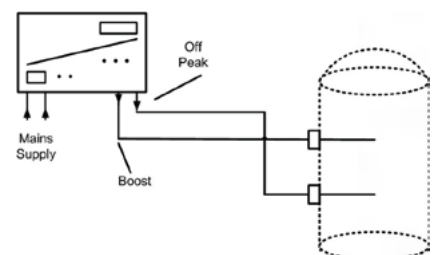

## Technical Data

Supply Voltage	230V +10% / -15%
Frequency	50/60Hz
Power Consumption	1.2W
Program Cycle	24 Hours
Contact Rating	13A Resistive 230V Suitable for immersion heaters up to 3kW
Contact Type	Micro-disconnection on control. Disconnection to immersion heater(s) via double pole rocker switch
Memory Reserve	3 years
Timing Accuracy	+/- 0.5 sec per day at +23oC
Operation Temperature	0oC to 35oC
Shock Protection	Class 1
Live Parts	Enclosed
Enclosure Protection	IP30
Dimensions	169mm x 114mm x 60mm deep (excluding rocker switch & buttons)
Conforms to	BS EN60730

## Electrical Connections

### Internal Wiring Diagram

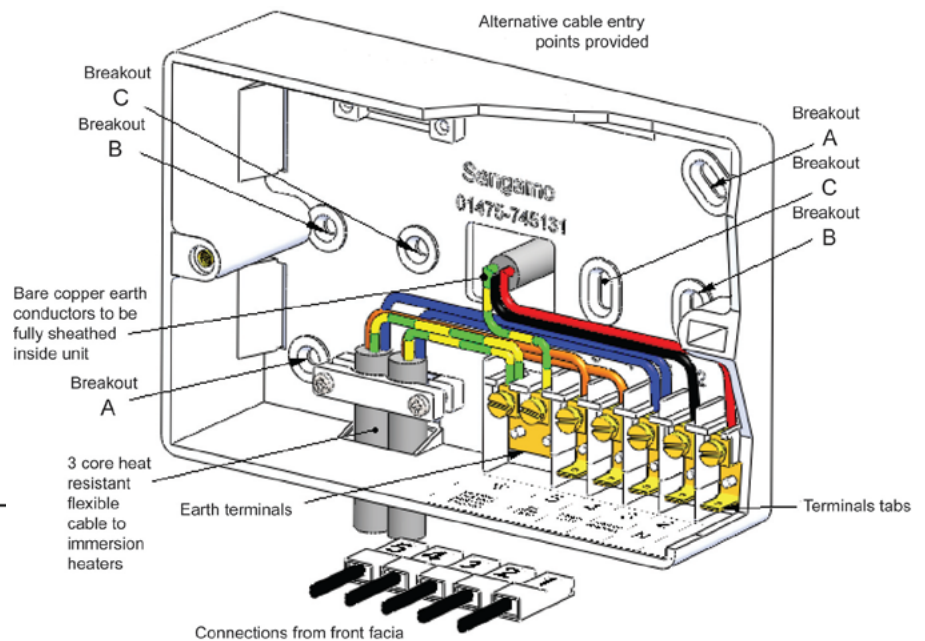
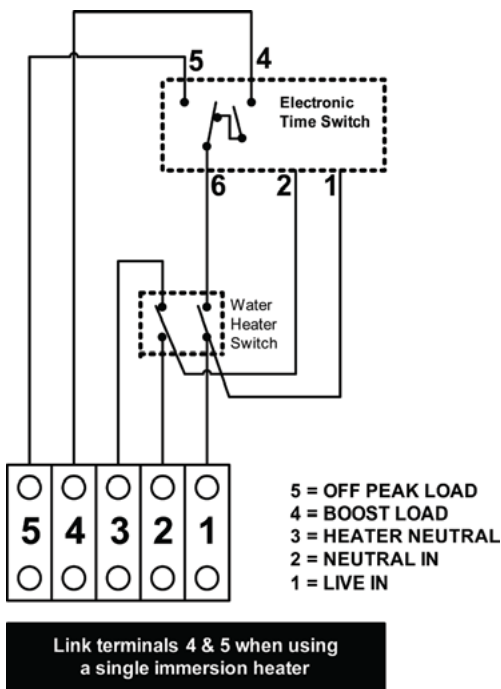

## Contact Us: 01475 745131

### CUSTOMER CARE POLICY

As part of Sangamo's continuous improvement program, the Company operates a Customer Care Policy. This means that we welcome your comments and complaints, as it can only help us to improve our services to you, our customer.



Sangamo Limited, Industrial Estate, Port Glasgow,  
 Renfrewshire PA14 5XG

Tel: 01475 745131 Fax: 01475 744567

Email : enquiries@sangamo.co.uk Web: www.sangamo.co.uk