

**14. Disposal :**



Please disposal of the unserviceable device according to the current statutory requirements.

**15. Technical specification :**

	LED Derby II	LED Double Derby II
<b>Voltage :</b>	120/240Vac, 50/60Hz	
<b>Fuse :</b>	1A (Fast blow)	
<b>LED :</b>	3 x 3W LEDS (Red, Green, Blue)	
<b>LED Life:</b>	10,000 hrs	
<b>Power Consumption:</b>	20W	
<b>Dimensions :</b>	365 x 295 x 190mm	385 x 295 x 300mm
<b>Weight:</b>	3kg	4kg

Note: Conforms to Laser and LED Safety standard BSEN60825-1 2007

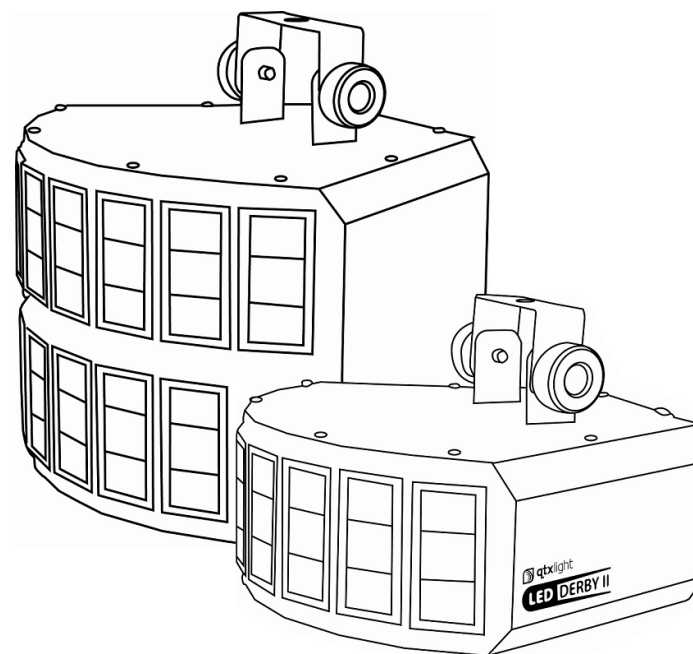

# LED Derby & Double Derby II

## User manual

151.576UK & 151.575UK

Version 2.0

**LED DERBY & DOUBLE DERBY II: For indoor use only**

	<p><b>CAUTION! Please read this manual carefully before operating! Pay special attention to Sections 3 &amp; 5 of this document.</b></p>
---	--

**1. General introduction :**

Our classic LED Derby lights have been upgraded with the latest LED technology to offer a more exciting light effect at an affordable price. This upgraded version is now smaller, lighter and has been fitted with efficient high power LEDs and improved optics, resulting in a brighter output and ultra sharp beams. With the vastly improved built-in programs and 6 channel DMX, this light effect offers much more excitement than the previous model and is suitable for many applications such as permanent fixtures in bars, nightclubs as well as being portable enough for the mobile DJ.

**Features :**

- 3 x 3W LEDs (Red, green and blue)
- Auto mode, Sound activated (with auto mode when no sound detected), or DMX operated
- Master and Slave mode (inter-compatible with each other)
- 6 channel DMX
- Adjustable sound sensitivity
- Low power consumption
- IEC power daisy chain facility
- Includes mounting bracket

**13. DMX controlling:**

DMX Channel	Function & Value
<b>Channel 1</b>	000-255 Red brightness 0-100%
<b>Channel 2</b>	000-255 Green brightness 0-100%
<b>Channel 3</b>	000-255 Blue brightness 0-100%
<b>Channel 4</b>	000-255 Overall Dimmer 0-100%
<b>Channel 5</b>	000-255 Strobe speed slow to quick
<b>Channel 6</b>	000-255 Rotation Speed Slow to Fast

**Dip Switch addressing**

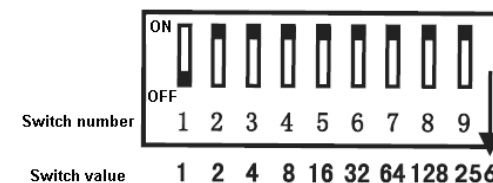

To set the DMX address please see the example table below and for more details visit the QTX website [www.qtxlight.com](http://www.qtxlight.com)

(Note: 1 = On, 0 = Off)

DMX Address	DIP Switches								
	1	2	4	8	16	32	64	128	256
1	1	0	0	0	0	0	0	0	0
2	0	1	0	0	0	0	0	0	0
3	1	1	0	0	0	0	0	0	0
...	..	..	..	..	..	..	..	..	..
410	0	1	0	1	1	0	0	1	1

**12. Functions guide:**

On	Off	Function
1	2,3,4,5,6,7,8,9,10	Sound to light mode. When no sound or sound sensitivity is set to minimum then unit will be in Auto mode
1, 2	3,4,5,6,7,8,9,10	Sound to light mode. When no sound or sound sensitivity is set to minimum then unit will be in Auto mode (SLOW)
1,3	2,4,5,6,7,8,9,10	Sound to light mode. When no sound or sound sensitivity is set to minimum then unit will be in Auto mode (FAST)
9	1,2,3,4,5,6,7,8,10	Auto rotating mode (All LEDs on)
10	1,2,3,4,5,6,7,8,9	Slave Mode

\* Use these switches in combination with the others listed when connecting one or more fixtures by a DMX cable.

When a DMX cable is connected the items automatically switch to DMX mode. You can see how to set the address in the next section.

**2. Package contents:**

Please check the contents to ensure that the product has been received in good condition.

Light x 1unit	IEC Power Lead x 1	User's Guide x 1pcs
---------------	--------------------	---------------------

If you find any accessory is missing or the lighting has arrived with any problems, please contact your local dealer at once. This product contains no serviceable parts to make no attempt to try to fix or modify this item yourself as you may invalidate the warranty. We recommend you keep the original package and proof of purchase for any possible replacement or returned demand.

**3. Installation :**

This product is for professional use only and every person involved with the installation, operation and maintenance of this device should be qualified and follow the instructions of this User Guide. We recommend that this product is not used for audience scanning and should be used within the guidelines of radiation of lasers used for display purposes "HSG95". (copies of the guidance can be downloaded from the HSE website

<http://www.hse.gov.uk/pubns/priced/hsg95.pdf>

When you connect to the main power supply the device will illuminate and the light effect will change with music when in sound activated mode.

**4. Mounting instruction :**

The fixture may be mounted in any position provided there is adequate room for ventilation. It is important never to obstruct the fan or vent pathway. Mount the fixture using a clamp. Unscrew the safety screws underneath the device and fix a G-Clamp to the fixture. After finding desired position tighten the G-Clamp. When selecting installation location, take into consideration routine maintenance. Safety cables must always be used. Never mount in places where the fixture will be exposed to rain, high humidity, extreme temperatures changes or restricted ventilation. The product should be securely mounted so that its output emission is always directed away from people and at objects that are able to reflect emission in a hazardous direction. In this regard, the separation distances cited in HS(G)95 should be observed.

**5. Caution :**

For your safety, please kindly pay attention to all of the warnings below:

- Always plug in the power plug last and disconnect from the mains, when the device is not in use or before cleaning.
- Do not install and operate the device in rain or extreme heat, moisture or dusty environments.
- This device is for indoor use only and in a dry environment.
- Do not switch on immediately but wait until it reaches room temperature, if the device has been exposed to drastic temperature fluctuations.
- Do not shake the device and avoid brute force when installing or operating

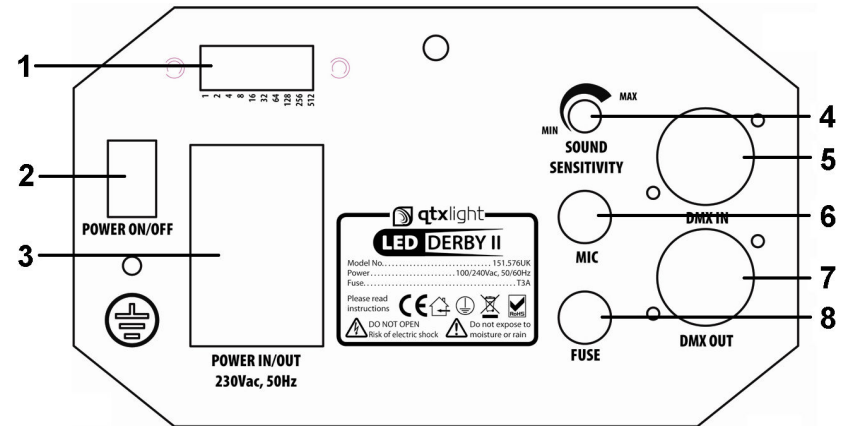
**11. Rear display :**

1. DMX Dip switch control
2. Power ON/OFF Switch
3. IEC Power in and Power loop out
4. Sound sensitivity control
5. DMX IN
6. Microphone
7. DMX OUT
8. Fuse

\* NOTE: Rear display is the same for the Double Derby II version

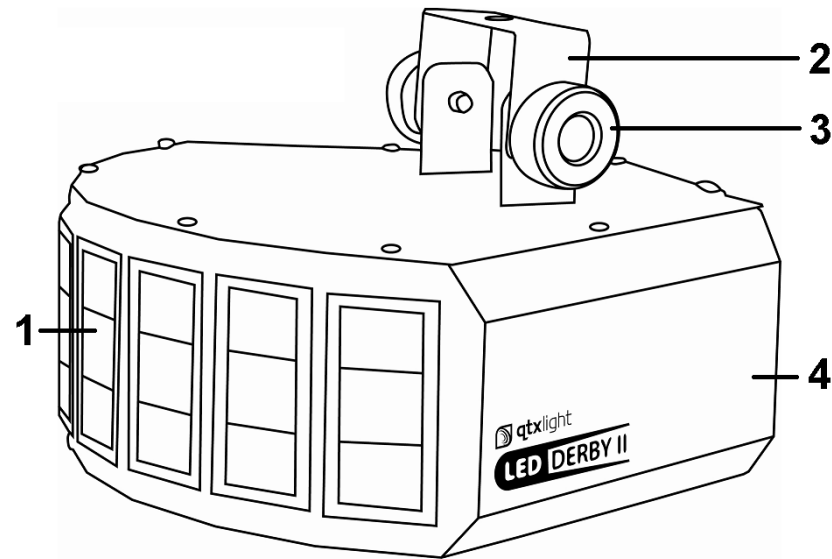
**10. Layout:**

1. Lens
2. Mounting bracket
3. Thumb screw
4. Housing cover

- Do not use the device during thunderstorms and please disconnect the power.
- Do not use solvents or aggressive detergent to clean the device. Use a soft and clean cloth.
- Do not modify the device or the connected power cord without authorization.
- Use appropriate safety-rope.
- Do not stare into the light, this product emits hazardous levels of optical radiation and will cause serious injury to the eyes if viewed at close range.
- This product should be securely mounted so that its output emission is always directed away from people and at objects that are able to reflect emission in a hazardous direction. In this regard, the separation distances cited in HS(G)95 should be observed.
- The symbol  determines the minimum distance from lighted objects. The minimum distance between light-output and the illuminated surface must be more than 0.5m.

**6. Connect with power supply:**

Use the plug to connect to the main power supply as following.

Line	Connection	International signal
Brown	Live	L
Blue	Neutral	N
Yellow /Green	Earth	E

**7. Replacing fuse :**

Disconnect from the main power supply first, then remove the fuse from the IEC Socket or fuse holder . Replace with a fuse of the correct rating as stated on product label or user guide.

**8. General maintenance :**

To maintain optimum performance and minimize wear, fixtures should be cleaned frequently. Usage and environment are contributing factors in determining frequency. As a general rule, fixtures should be cleaned at least twice a month. Dust build-up reduces light output performance and can cause overheating. This can lead to reduced lamp life and increased mechanical wear. Be sure to power off fixture before conducting maintenance.

Unplug fixture from power. Use a vacuum or air compressor and a soft brush to remove dust collected on external vents and internal components. Clean all

glass when fixture is cold with a mild solution to the cloth or tissue, and drag dirt and grime to the outside of the lens. Gently polish optical surface until they free of haze and lint.

The cleaning of internal and external optical lenses and/or mirrors must be carried out periodically to optimize light output. Cleaning frequently depends

on the environment in which the fixture operates: damp, smoky or particularly dirty surroundings can require cleaning fluid. Always dry the parts carefully. Clean the external optics at least every 20 days.

**9. Quick trouble shooting :**

7.1 If the unit does not function – Check that the main power is on and the fuse is intact.

7.2 If the unit is not reacting to music – check the unit is in “sound to light” mode and that the sensitivity control is fully clockwise.

7.3 If the product is not reacting to DMX signals, check the cables and connections