

Spectrum Laser

User manual

152.753UK

Version 1.0



- Please read this manual fully before installing or operating this product as it contains important safety information relating to its installation and operation.



- This Class 3B laser product emits hazardous levels of optical radiation and will cause injury to the eyes if viewed directly.
- This product is not suitable for projection directly at audiences or other personnel.
- This product must not be used for any form of audience scanning application and is for professional use only.

15. Disposal :



Please disposal of the unserviceable device according to the current statutory requirements.

16. Specification:

Voltage : 230Vac, 50/60Hz	Blue : 300mW 455nm
Fuse : 2A Slow blow	DMX Channels : 9
Laser Class : 3B 	Dimensions : 220 x 176 x 99mm
Red Laser: 150mW 650nm	Power Consumption : 15W
Green Power : 50mW Green	Weight : 1.6kg

Note: Conforms to Laser and LED Safety standard BSEN60825-1 2007 incorporating corrigendum 2008

Manual copyright protected by QTX Light

14. DMX controlling :

DMX CHANNEL	DMX VALUE	DESCRIPTION
1 (Mode)	000-010	Blackout
	011-062	Sound to light
	063-160	Auto Mode
	161-255	DMX 512 Mode
2 (Pattern Select)	000-255	Laser Pattern select (when CH1 in DMX mode)
3 (X Rotation)	002-131	X axis rotation static
	132-255	X axis rotation auto
4 (Y Rotation)	002-131	Y axis rotation static
	132-255	Y axis rotation auto
5 (X Movement)	002-131	X axis move position static
	132-255	X axis movement auto
6 (Y Movement)	002-131	Y axis move position static
	132-255	Y axis movement auto
7 (Zoom)	002-083	Zoom in / out manually
	084-163	Zoom out automatically
	164-255	Zoom in automatically
8 (Rotate)	002-108	Rotate position manually
	109-255	Rotation automatically
9 (Scan Speed)	000-255	Control the scanner speed of the patterns

1. Introduction:

This Class 3B  laser product should only be installed and used by personal who are trained in the management of laser radiation and are able to operate in accordance within the guidance given by the Health and Safety Executive (HSE) in HS(G)95: "The Radiation Safety of Lasers used for Display purposes".

Copies of this guide can be downloaded from the HSE website below:

www.hse.gov.uk/pubns/priced/hsg95.pdf

This product contains no user-serviceable parts. Under no circumstances should any attempt be made by the user to dismantle or modify it in any way.

2. Installation and mounting instructions:

This product must be securely mounted so that its emission is always directed away from people and objects that are able to reflect the emission towards people. In this regard the separation distances of 3 metres vertically and 2.5 metres horizontally, cited in HS(G)95 and shown overleaf must be observed.

Venue cross-sectional view

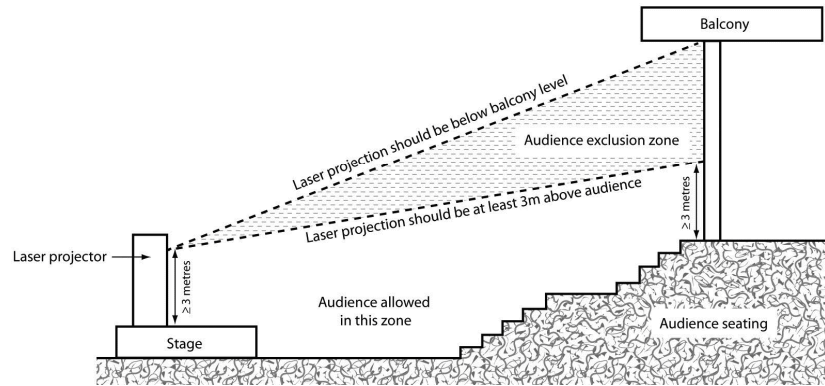

Venue birds eye view

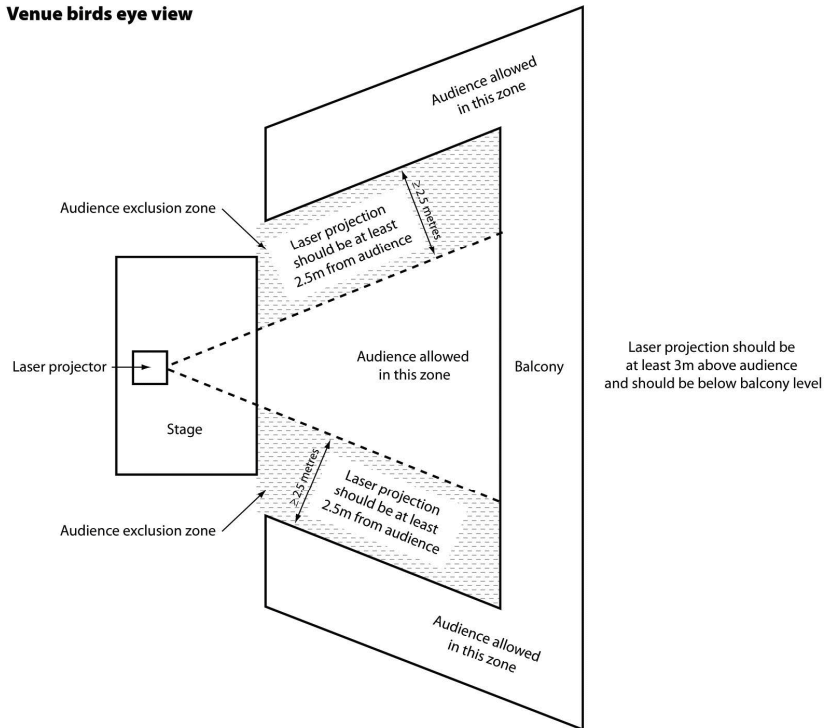

13. DMX-512 connection :

The fixture is equipped with 3-pin XLR connectors for DMX input and output. The SE connectors are wired in parallel. Only use a shielded twisted-pair cable designed for 3-pin XLR-plugs and connectors in order to connect the controller with the fixture or one fixture with another.

DMX - output
XLR mounting-sockets (rear view):



DMX-input
XLR mounting-plugs (rear view):

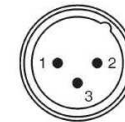

- 1 - Shield
- 2 - Signal (-)
- 3 - Signal (+)

Building a serial DMX-chain:

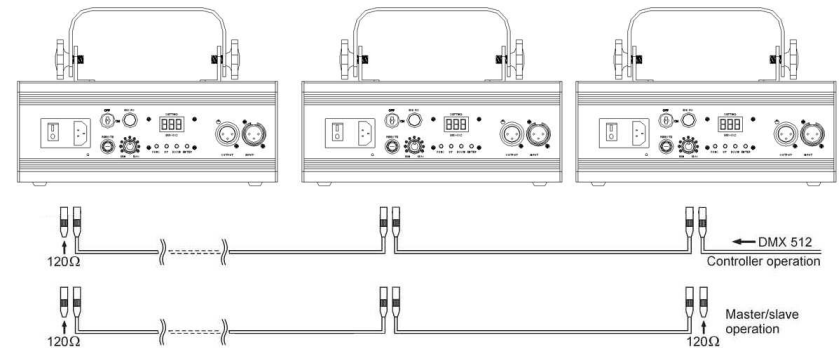

Caution: At the last fixture, the DMX-cable has to end with a terminator. Solder a 120 Ohm resistor between PIN 2 (-) and PIN 3 (+) into a 3-pin XLR-plug and plug it in the DMX-output of the last fixture.

12. Functions guide:

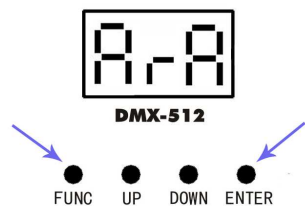

- MENU:** Select Function
- UP:** Scroll up
- DOWN:** Scroll down
- ENTER:** Confirm selection

DISPLAY	STAND ALONE MODE PREPROGRAM EFFECT
AUE	Auto Running Random Effect
SOU	Sound Activated Random Effect
H96	Colour Select Mode
001	DMX Address
SLA	Slave Mode

Always allow enough room for adequate ventilation. It is important never to obstruct the fan or air-vents

The product must be fixed to suitable rigging using an appropriate clamp and the fixing screws tightened to prevent the fixture from moving. A suitable safety cable should also be used.

When selecting the installation location, take into account the need for routine maintenance and also make sure that there is no possibility of any unauthorized persons interfering with the installation. Never install in locations where the product could be exposed to rain, high humidity, extreme temperatures, or restricted ventilation. Also ensure that the laser is located a minimum of 0.5metres from any potentially flammable materials

SPECTRUM LASER: For indoor use only**3. General introduction:**

This spectacular effect combines red, green and blue lasers to create an amazing 7 colour display. It can be operated in standalone, auto, sound to light, and 9 channel DMX modes. With a combined power of 0.5W this laser is one of the brightest in its class, making it suitable for mobile DJs through to venue installers.

Features :

- 7 Colour laser effect (RGB Mix)
- 128 stepper motor laser patterns
- 0.5W total laser power (Red: 150mW, Green 50mW, Blue: 300mW)
- 3 colour operating modes (7 colour, RGY or white)
- Auto, sound to light and 9 channel DMX modes
- Master/slave mode
- Easy digital display to set the mode of operation
- Key controlled for laser emission safety
- We recommend that this product is used within the guidelines HSG95

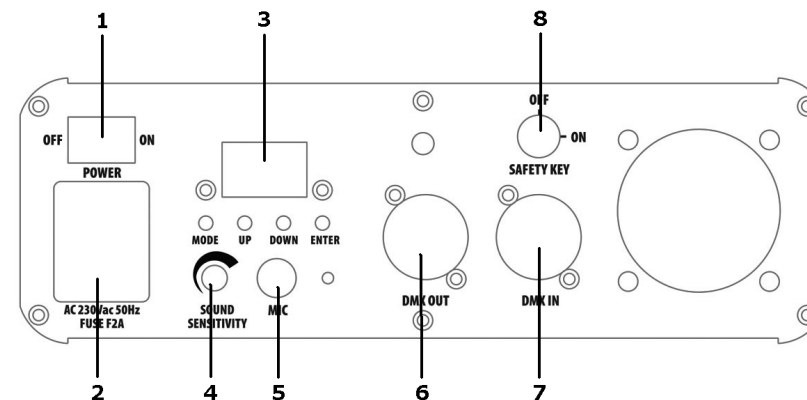
11. Rear display:

1. Power ON/OFF Switch
2. IEC Power IN
3. Digital display
4. Sound sensitivity
5. Microphone
6. DMX OUT
7. DMX IN
8. Safety Key

10. Layout:

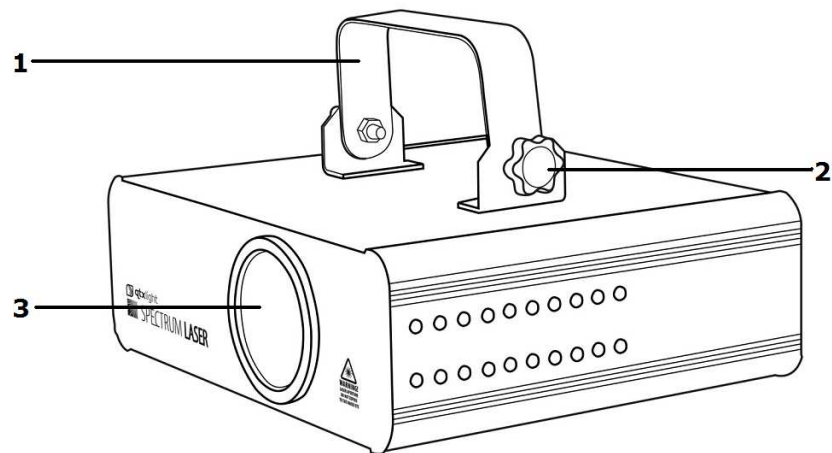

- 1. Mounting bracket
- 2. Thumb screw
- 3. Laser Aperture

4. Packaging contents:

Please check the contents to ensure that the product has been received in good condition.

Laser x 1unit	User's Guide x 1pc
IEC Power Lead x 1pc	Safety Keys x 2pcs

If you find any accessory is missing or the lighting has arrived with any problems, please contact your local dealer at once. This product contains no user-serviceable parts so make no attempt to try to fix or modify this item yourself as this will invalidate the warranty. We recommend you keep the original package and proof of purchase for any possible replacement or returned demand.

5. Connect with power supply:

Use the plug to connect to the main power supply as following.

Line	Connection	International signal
Brown	Live	L
Blue	Neutral	N
Yellow /Green	Earth	E

6. Replacing fuse :

Disconnect from the main power supply first, then remove the fuse from the IEC Socket or fuse holder . Replace with a fuse of the correct rating as stated on product label or user guide.

7. Caution:

For your safety, please kindly pay attention to all of the warnings below:

- Always plug in the power plug last and disconnect from the mains when the device is not in use or before cleaning.
- Do not install and operate the device in rain or extreme heat, moisture or dusty environments.
- This device is for indoor use only and in a dry environment.
- Do not switch on immediately. Wait until the unit reaches room temperature.
- Do not shake the device and avoid brute force when installing or operating
- Do not use the device during thunderstorms and please disconnect the power.
- Do not use solvents or aggressive detergent to clean the device. Use a soft and clean cloth.
- Do not modify the device or the connected power cord without authorization.
- Do not stare into the aperture. This product emits hazardous levels of optical radiation and will cause serious injury to the eyes if viewed at close range.
- This product should be securely mounted so that its output emission is always directed away from people and at objects that are able to reflect emission towards people. In this regard, the separation distances cited in HS(G)95 should be observed.
- The symbol  determines the minimum distance from lighted objects. The minimum distance between light-output and the illuminated surface must be more than 0.5m.

8. General maintenance:

Be sure to power off the fixture before conducting maintenance.

To maintain optimum performance and minimize wear, fixtures should be cleaned frequently. Usage and environment are contributing factors in determining frequency. As a general rule, fixtures should be cleaned at least twice a month. Dust build-up reduces can reduce light output & performance as well as overheating. This can lead to reduced life and increased mechanical wear.

Unplug fixture from power. Use a vacuum or air compressor and a soft brush to remove dust collected on external vents and internal components. Clean all glass when fixture is cold with a mild solution to the cloth or tissue, and drag dirt and grime to the outside of the lens. Gently polish optical surfaces until they are free of haze and lint.

The cleaning of internal and external optical lenses and/or mirrors must be carried out periodically to optimize light output. Cleaning frequently depends on the environment in which the fixture operates: damp, smoky or particularly dirty surroundings can require cleaning fluid. Always dry the parts carefully. Clean the external optics at least every 20 days.

9. Quick trouble shooting :

7.1 If the unit does not function – Check that the main power is on and the fuse is intact.

7.2 If the unit is not reacting to music – check the unit is in “sound to light” mode and that the sensitivity control is fully clockwise.

7.3 If the product is not reacting to DMX signals, check the cables and connections