

ILW2

IN-LINE WIRELESS CONTROLLER FOR SINGLE COLOUR LED TAPE

Item ref: 153.698UK

User Manual



WARNING: This product is intended for professional installation of single colour LED tape and should be connected by qualified personnel in accordance with electrical safety standards. Ensure that the rated load indicated is not exceeded.

Installation

The ILW2 controller can be employed to control Fluxia single colour LED tape operating from a 5-24Vdc power supply. Maximum short term current load is rated at 12A. For constant full power output, it is advised to limit this to 6A load.

For Fluxia single colour LED tape (153.705-153.718UK), it is recommended to connect no more than 3 x 5m tapes radially from the same controller. When connecting 5m tapes to make a longer run (up to 15m), it is advised to use bypass wiring instead of connecting end-to-end to avoid noticeable voltage drop at the furthest end from the power supply. Examples are shown below.

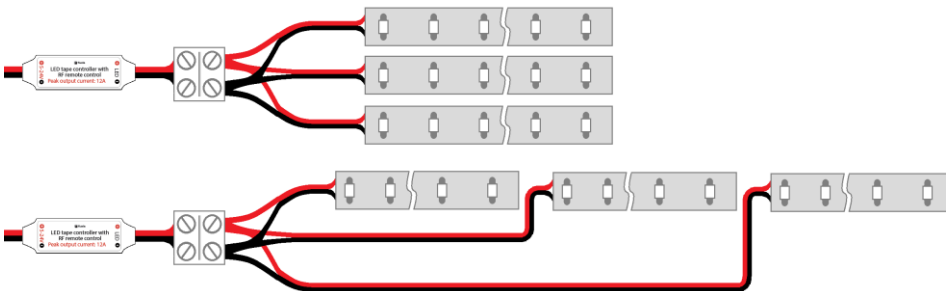

Remote control

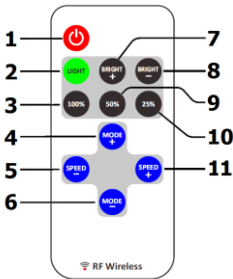

- | | | |
|-----|---------|--|
| 1. | POWER | LED on / standby button |
| 2. | LIGHT | switches from pattern to static light mode |
| 3. | 100% | sets static light brightness to 100% |
| 4. | MODE+ | steps upwards through modes |
| 5. | SPEED- | reduces speed of pattern |
| 6. | MODE- | steps downwards through modes |
| 7. | BRIGHT+ | increases brightness |
| 8. | BRIGHT- | decreases brightness |
| 9. | 50% | sets static light brightness to 50% |
| 10. | 25% | sets static light brightness to 25% |
| 11. | SPEED+ | increases speed of pattern |

- Remove the clear tab from the handheld remote to engage the battery (replacement CR2025 button cell)
- To switch LEDs on, press the POWER button (from standby, the last setting is resumed)
- If there is no response from the handset, it may be necessary to pair the handset to the controller (see "Pairing" below)
- MODE+ and - buttons step through the 8 preset programmes in sequence (shown below)
- SPEED+ or - will alter the rate of change in the selected mode
- LIGHT button overrides the pattern mode to give a static light setting
- BRIGHT+ or - will change the brightness in static mode
- Preset brightness can be jumped to via the 25%, 50% or 100% buttons
- Press POWER to enter standby mode (all LEDs off)

Pairing: If the LED controller does not respond to the RF remote handset, disconnect DC power from the controller. Reconnect the DC power to the controller and within 5 seconds of powering on, hold down the "100%" and "25%" buttons simultaneously. The controller should now be paired with the handset and should respond to it.

Preset	Name	Description
1	Random Glow	Fade in and out at random brightness & intervals
2	Regular Glow	Fade between fully on and off at a regular rate
3	Half Glow	Fade between fully on and half-on at a regular rate
4	Flicker	Flash on and off at a fast regular rate
5	Offset Flash	Flash on and off with pause at a regular rate
6	Even Flash	Flash on and off evenly at a regular rate
7	SOS	3 short - 3 long - 3 short Morse Code flash sequence
8	Strobe	Very short burst at regular intervals

Specifications	
Power supply	5-24Vdc, 12A (50% duty cycle) or 6A (100% duty cycle)
Remote control frequency	433MHz
Lead length (power input, LED output)	100mm
Connections	Red wire "+", black wire "-"
Controller dimensions	42 x 13 x 5mm
Weight	4.8g

*Errors and omissions excepted.
Copyright© 2014. AVSL Group Ltd.*

ILW4

IN-LINE WIRELESS CONTROLLER FOR RGB LED TAPE

Item ref: 153.699UK

User Manual



WARNING: This product is intended for professional installation of RGB LED tape and should be connected by qualified personnel in accordance with electrical safety standards. Ensure that the rated load indicated is not exceeded.

Installation

The ILW4 controller can be employed to control Fluxia RGB LED tape operating from a 5-24Vdc power supply. Maximum short term current load is rated at 3 x 4A. For constant full power output, it is advised to limit this to 3 x 2A load.

There are 2 versions of Fluxia RGB LED tape - 153.720UK has 60 LEDs per metre and 153.721UK has 30 LEDs per metre. It is recommended that each controller is connected to no more than 300 RGB LEDs (i.e 1 x 5m roll of 153.720UK or 2 x rolls of 153.721UK connected in parallel).

For longer runs, each subsequent roll should be linked using the ILA4 amplifier (153.701UK). The ILA4 also accepts 5-24Vdc and connects from the end of a controlled length of RGB LED tape to the beginning of the next length of RGB LED tape to match the patterns/colours of the first tape. (also 3 x 4A peak, 3 x 2A continuous output)

Connection is via a 4-pin coupler, as supplied with Fluxia RGB LED tape. Ensure that the red triangle is connected to "+" or "Common" on the LED tape.

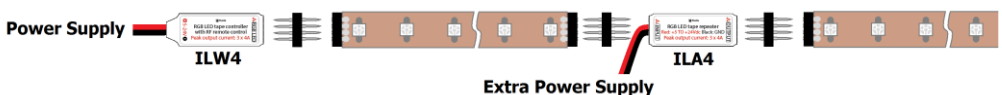

Remote control

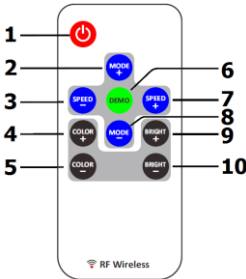

- | | |
|-------------|---------------------------------|
| 12. POWER | LED on / standby button |
| 13. MODE+ | steps upwards through modes |
| 14. SPEED- | reduces speed of pattern |
| 15. COLOR+ | steps upwards through colours |
| 16. COLOR- | steps downwards through colours |
| 17. DEMO | initiates the demo mode |
| 18. SPEED+ | increases speed of pattern |
| 19. MODE- | steps downwards through modes |
| 20. BRIGHT+ | increases brightness |
| 21. BRIGHT- | decreases brightness |

- Remove the clear tab from the handheld remote to engage the battery (replacement CR2025 button cell)
- To switch LEDs on, press the POWER button (from standby, the last setting is resumed)
- If there is no response handset to the controller (see from the handset, it may be necessary to pair the "Pairing" below)
- To test all LED functions, pressing the DEMO button will initiate a full demo programme
- MODE+ and - buttons step through the 19 preset programmes in sequence (shown below)
- SPEED+ or - will alter the rate of change in the selected mode
- COLOR+ or - will override the pattern mode and step through 20 static colours
- BRIGHT+ or - will change the brightness of the selected colour
- Press POWER to enter standby mode (all LEDs off)

Pairing: If the LED controller does not respond to the RF remote handset, disconnect DC power from the controller. Reconnect the DC power to the controller and within 5 seconds of powering on, hold down the "SPEED-" and "SPEED+" buttons simultaneously. The controller should now be paired with the handset and should respond to it.

Preset	Name	Description
1 - 2	Scrolls	2 types of scrolls through full spectrum of colours
3	RGB Glow	Fade between fully on and half through Red, Green, Blue
4	7 Colour Glow	Fade between fully on and half through 7 different colours
5 - 10	Static Glows	Glow presets for Blue, Cyan, Green, Red, White
11	RGB Jump	Switch between Red, Green and Blue
12	6 Colour Jump	Switch between 6 different colours
13	RGB Flash	Flash on and off through Red, Green and Blue
14 - 18	Static Strobes	Regular, very short burst for Blue, Cyan, Green, Red, White
19	RGB Strobe	Regular, very short burst through Red, Green, Blue

Specifications	
Power supply	5-24Vdc, 12A (to supply 3 x 4A max – 50% duty cycle)
Remote control frequency	433MHz
Lead length (power input)	100mm
Connections	4-pin socket (Common+ / Green / Red / Blue)
Controller dimensions	42 x 13 x 5mm
Weight	4.8g

*Errors and omissions excepted.
Copyright© 2014. AVSL Group Ltd.*

ILC2

IN-LINE CONTROLLER FOR
SINGLE COLOUR LED TAPE

Item ref: 153.700UK

User Manual



WARNING: This controller is intended for professional installation of single colour LED tape and should be connected by qualified personnel in accordance with electrical safety standards. Ensure that the rated load indicated is not exceeded.

Installation

The ILC2 controller can be employed to control single colour LED tape operating from a 5-24Vdc power supply. Maximum short term current load is rated at 12A. For constant full power output, it is advised to limit this to 6A load.

For Fluxia single colour LED tape (153.705-153.718UK), it is recommended to connect no more than 3 x 5m tapes radially from the same controller. When connecting 5m tapes to make a longer run (up to 15m), it is advised to use bypass wiring instead of connecting end-to-end to avoid noticeable voltage drop at the furthest end from the power supply. Examples are shown below.

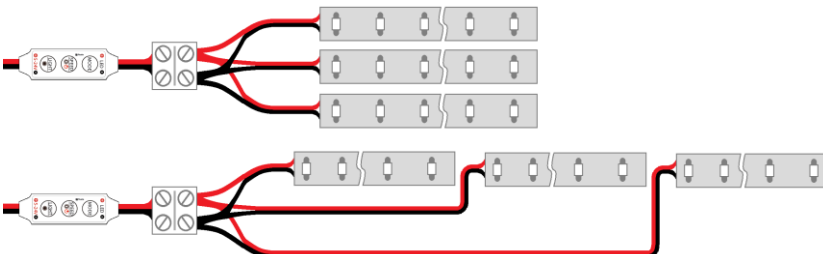

Controls

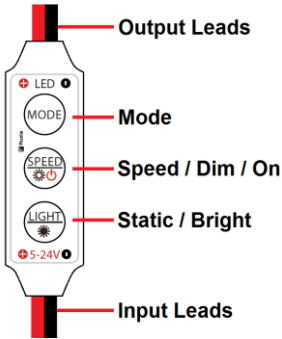

- To switch LEDs on or off, press and hold Speed/Dim/On button for 2 seconds
- Mode button steps through the 8 preset programmes in sequence (shown below)
- Pressing the Speed/Dim/On button in a pattern cycles through various speed settings (10 in total)
- Pressing the Static/Light button switches mode from pattern to static – repeated presses increase brightness
- Pressing Speed/Dim/On in static mode dims the LEDs

Preset	Name	Description
1	Random Glow	Fade in and out at random brightness & intervals
2	Regular Glow	Fade between fully on and off at a regular rate
3	Half Glow	Fade between fully on and half-on at a regular rate
4	Flicker	Flash on and off at a fast regular rate
5	Offset Flash	Flash on and off with pause at a regular rate
6	Even Flash	Flash on and off evenly at a regular rate
7	SOS	3 short - 3 long - 3 short Morse Code flash sequence
8	Strobe	Very short burst at regular intervals

Specifications

Power supply (input/output)	5-24Vdc, 12A max (short term)
Lead length (input/output)	100mm
Controller dimensions	42 x 13 x 5mm
Weight	7.2g

*Errors and omissions excepted.
Copyright© 2014. AVSL Group Ltd.*

ILC4 and ILA4

Item ref: 153.702UK, 153.701UK

IN-LINE CONTROLLER AND AMPLIFIER FOR RGB LED TAPE

User Manual



WARNING: These products are intended for professional installation of RGB LED tape and should be connected by qualified personnel in accordance with electrical safety standards. Ensure that the rated load indicated is not exceeded.

Installation

The ILC4 controller can be employed to control Fluxia RGB LED tape operating from a 5-24Vdc power supply. Maximum short term current load is rated at 3 x 4A. For constant full power output, it is advised to limit this to 3 x 2A load.

There are 2 versions of Fluxia RGB LED tape - 153.720UK has 60 LEDs per metre and 153.721UK has 30 LEDs per metre. It is recommended that each controller is connected to no more than 300 RGB LEDs (i.e 1 x 5m roll of 153.720UK or 2 x rolls of 153.721UK connected in parallel).

For longer runs, each subsequent roll should be linked on using the ILA4 amplifier. The ILA4 also accepts 5-24Vdc and connects from the end of a controlled length of RGB LED tape to the beginning of the next length of RGB LED tape to match the patterns/colours of the first tape. (also 3 x 4A peak, 3 x 2A continuous output)

Connection is via a 4-pin coupler, as supplied with Fluxia RGB LED tape. Ensure that the red triangle is connected to "+" or "Common" on the LED tape.

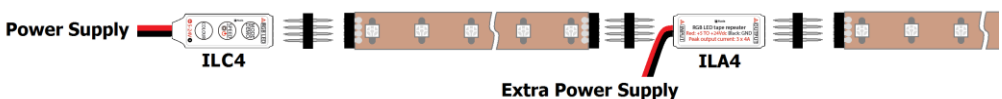

Controls

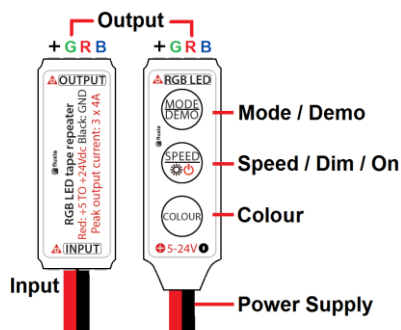

- To switch LEDs on or off, press and hold Speed/Dim/On button for 2 seconds
- Mode/Demo button steps through the 8 preset programmes in sequence (shown below)
- Pressing Speed/Dim/Colour cycles through 10 different speed levels
- Holding the Mode/Demo button for 2 seconds enters a demo mode, cycling through all presets
- Press the Colour button to enter static colour mode
- Pressing Colour again changes to one of 20 colours
- Pressing Speed/Dim/On in static colour mode dims the LEDs through 5 levels of brightness

Preset	Name	Description
1 - 2	Scrolls	2 types of scrolls through full spectrum of colours
3	RGB Glow	Fade between fully on and half through Red, Green, Blue
4	7 Colour Glow	Fade between fully on and half through 7 different colours
5 - 10	Static Glows	Glow presets for Blue, Cyan, Green, Red, White
11	RGB Jump	Switch between Red, Green and Blue
12	6 Colour Jump	Switch between 6 different colours
13	RGB Flash	Flash on and off through Red, Green and Blue
14 - 18	Static Strobes	Regular, very short burst for Blue, Cyan, Green, Red, White
19	RGB Strobe	Regular, very short burst through Red, Green, Blue

Specifications

Power supply	5-24Vdc, 12A (to supply 3 x 4A max – 50% duty cycle)
Lead length (power input)	100mm
Connections	4-pin socket (Common+ / Green / Red / Blue)
Controller dimensions	42 x 13 x 5mm
Weight	4.8g

*Errors and omissions excepted.
Copyright© 2014. AVSL Group Ltd.*