



# BUBBLE MACHINE

## 160.571

**INSTRUCTION MANUAL  
HANDLEIDING  
MODE D'EMPLOI  
BEDIENUNGSANLEITUNG  
BRUGSANVISNING**



CAUTION: Risk of electric shock. Do not open  
LET OP: Niet openen. Gevaar voor elektrische schok  
ATTENTION : Risque d'électrocution. Ne pas ouvrir  
ACHTUNG: Stromschlaggefahr. Nicht Öffnen  
ADVARSEL: Må ikke åbnes. Risiko for elektrisk chok



Do not expose to rain / moisture  
Niet in vochtige ruimtes gebruiken  
Tenir à l'abri de la pluie et de l'humidité  
Vor Regen und Feuchtigkeit schützen  
Må ikke anvendes i våde/fugtige omgivelser

**WARNING**

- Read the instruction manual thoroughly prior to using the unit.
- Keep this manual for future reference.
- Keep out of the reach of children.
- For indoor use only in dry rooms.
- Do not block the fan or the bubble wheel.
- Do not block the ventilation holes.
- Use good quality bubble oil.
- Do not use inflammable chemicals.
- Do not use the unit at room temperatures of more than 40°C.
- Switch the unit off before you refill the tank.
- If the unit is fitted with an earthed plug, this must be connected to an earthed outlet.
- The unit does not contain any user replaceable parts other than those specified in this manual.
- If the plug and/or mains lead are damaged, they need to be repaired by a qualified technician.
- During installation, make sure that nobody is standing in the mounting area.
- The unit contains voltage carrying parts. Do NOT open the housing.
- Unplug the unit from the mains prior to repairs or maintenance.
- Never plug or unplug the unit with wet hands.
- If the unit is damaged to an extent that you can see internal parts, do not plug the unit into a mains outlet.
- Only connect this unit to an earthed mains outlet of 230Vac/50Hz and 10-16A.
- When you unplug the unit from the mains always pull the plug, never the lead.
- In order to prevent dropping of the unit, a safety fastening needs to be installed. This
- In order to avoid accidents in public premises, the local legal requirements and safety regulations/warnings must be fulfilled.

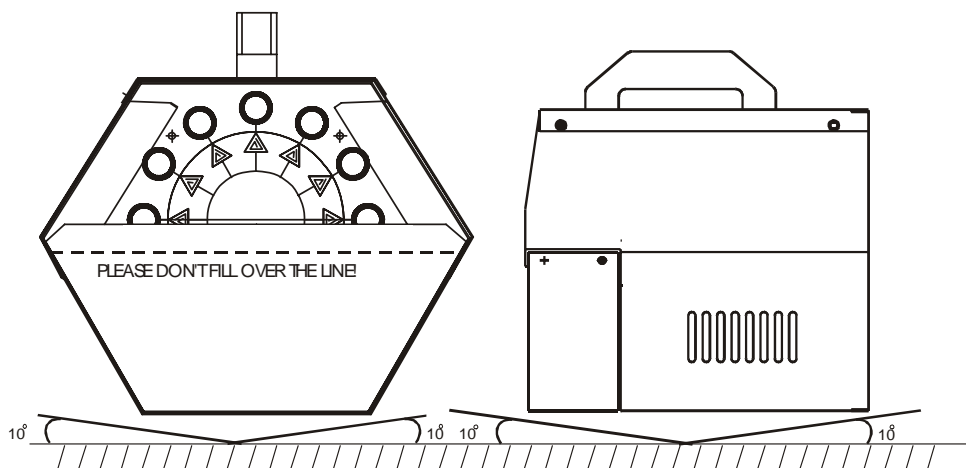
**Use**

- Place the unit on a flat, stable surface which must not be tilted more than 10° (see drawing)
- Fill the tank up to the marking with a good quality bubble fluid (SkyTronic 160.575).
- Switch the unit on via the On/Off switch on the rear side.
- Switch the unit off after use and unplug it from the mains if it will not be used for a long period of time.
- Rinse the unit regularly with clean water.

## **Specifications**

Power supply: ..... 230 VAC / 50 Hz  
Rotation speed: ..... 24 rpm  
Dimensions: .....250 x 240 x 272 mm  
Weight: ..... 3,8 kg

- Specifications and design subject to changes without prior notice

*Do not attempt to make any repairs yourself. This would invalid your warranty.*

*Do not make any changes to the unit. This would also invalid your warranty.*

*The warranty is not applicable in case of accidents or damages caused by inappropriate use or disrespect of the warnings contained in this manual.*

*SkyTronic UK cannot be held responsible for personal injuries caused by a disrespect of the safety recommendations and warnings. This is also applicable to all damages in whatever form.*