

Model Article Code	<b>CVAT PACK 2</b>
Model Description-1	<b>CVAT/4 -2000/315 ND</b>
Model Description-2	<b>Centrifugal Inline Acoustic Box Fan with pre-configured Variable Frequency Drive speed controller (VFD) supplied packaged as standard.</b> Suitable for circular ductwork (315mm diameter). Requires 1PH 230V 50Hz electrical supply.
Applications.	Commercial kitchen canopy extract systems.
Features & Benefits	<p>Robust centrifugal backward inclined impeller matched with an energy efficient 1PH motor (fan).</p> <p>Supplied as standard with a 1PH-3PH Variable Frequency Drive (VFD) speed controller, pre-configured for precise operation with S&amp;P 1PH CVAT fan.</p> <p>Motor overload protection provided by pre-configured VFD.</p> <p>Low noise levels. Includes fireproof insulated interchangeable panels. Suitable for duct airstream temperatures up to 40 °c.</p> <p>3 Year warranty</p>

<b>Pressure</b>	<b>0</b>	<b>50</b>	<b>100</b>	<b>150</b>	<b>200</b>	<b>250</b>	<b>300</b>	<b>350</b>	<b>400</b>
Airflow	0.342	0.306	0.262	0.206	0.080	N/A	N/A	N/A	N/A
<b>Pressure</b>	<b>450</b>	<b>500</b>	<b>550</b>	<b>600</b>					
Airflow	N/A	N/A	N/A	N/A					

Pressure = Pa

Airflow = m<sup>3</sup>/s

<b>Nom RPM</b>	<b>Max W</b>	<b>Max A</b>	<b>Max Airflow m<sup>3</sup>/s</b>	<b>Sound dB(A) @ 3m</b>	<b>Weight Kg</b>	<b>Circ. Duct Connect mm</b>	<b>Electrical Supply to VFD Controller</b>
1460	169	1.03	0.51	37	13.0	315	1PH 230V 50Hz

<b>Accessories</b>	
Model Article Code	<b>513820900</b>
Model Description-1	<b>ACOPEL F400 315/160 N</b>
Model Description-2	Flexible circular duct connectors (315mm Dia). Optional accessory for connecting CVAT fan to rigid circular ducting to isolate any vibration transmission. Supplied x1 each.
Model Article Code	<b>5137265200</b>
Model Description-1	<b>CTI CVA-N 250/315</b>
Model Description-2	Outdoor cover for use when installing the CVAT fan outside. Supplied x1 each.
Model Article Code	<b>5130861700</b>
Model Description-1	<b>KSE-45 Anti-vibration Mounts.</b>
Model Description-2	Anti-vibration mounts for isolating potential vibrations from CVAT fans. Supplied x4 per pack.

Model Article Code	<b>5401304100</b>
Model Description-1	<b>REB-CVF (Remote Mount Speed Control)</b>
Model Description-2	Remote mounted, single-gang size, ON/OFF switch and infinitely variable speed controller. Suitable for use when either VFD is too large or client requires smaller, more aesthetic, controller located at kitchen level.
Model Article Code	<b>L1000000681</b>
Model Description-1	<b>Cook Prep Switch.</b>
Model Description-2	Simple ON/OFF, and High/Low fan speed control functions. High/Low speeds defined at VFD as needed.

Dimensions	A	B	C	D	E	F	H
1400 250ND	500	457	574	250*	58	534	250
2000/315ND	500	457	574	315*	58	534	250
3000/355 ND	650	607	724	355*	58	684	325
4000/400 ND	650	607	724	400*	58	684	325
6000/450 ND	750	707	824	450*	58	784	375
6000/500 ND	650	607	724	500+	58	684	325
9000/500 ND	800	757	874	500*	58	834	400
12000/560 ND	900	826	977	560*	58	937	450
16000/630 ND	1000	959	1077	630*	58	1037	500
15000/710 ND	1100	1059	1177	710*	58	1137	550

**DIMENSIONS (mm)**

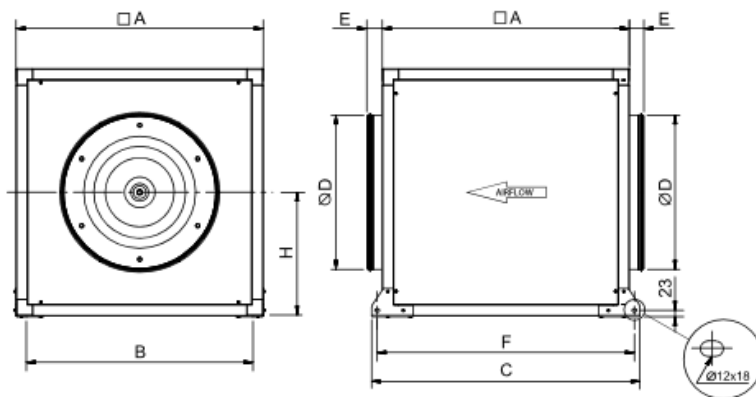

\* 6000/500 ND

