

Model Article Code	CVAT PACK 3
Model Description-1	CVAT/4-3000/355 ND
Model Description-2	Centrifugal Inline Acoustic Box Fan with pre-configured Variable Frequency Drive speed controller (VFD) supplied packaged as standard. Suitable for circular ductwork (355mm diameter). Requires 1PH 230V 50Hz electrical supply.
Applications.	Commercial kitchen canopy extract systems.
Features & Benefits	<p>Robust centrifugal backward inclined impeller matched with an energy efficient 3PH motor (fan).</p> <p>Supplied as standard with a 1PH-3PH Variable Frequency Drive (VFD) speed controller, pre-configured for precise operation with S&P 3PH CVAT fan.</p> <p>Motor overload protection provided by pre-configured VFD.</p> <p>Low noise levels. Includes fireproof insulated interchangeable panels.</p> <p>Suitable for duct airstream temperatures up to 40 °c.</p> <p>3 Year warranty</p>

Pressure	0	50	100	150	200	250	300	350	400
Airflow	0.739	0.691	0.639	0.577	0.501	0.394	0.187	N/A	N/A
Pressure	450	500	550	600					
Airflow	N/A	N/A	N/A	N/A					

Pressure = Pa

Airflow = m³/s

Nom RPM	Max W	Max A	Max Airflow m³/s	Sound dB(A) @ 3m	Weight Kg	Circ. Duct Connect mm	Electrical Supply to VFD Controller
1430	251	1.03	0.739	40	30.00	355	2.2Kw 230V 10A Max

Accessories	
Model Article Code	5138921000
Model Description-1	ACOPEL F400 355/160N
Model Description-2	Flexible circular duct connectors (355mm Dia). Optional accessory for connecting CVAT fan to rigid circular ducting to isolate any vibration transmission. Supplied x1 each.
Model Article Code	5537265300
Model Description-1	CTI CVA-N 355/400
Model Description-2	Outdoor cover for use when installing the CVAT fan outside. Supplied x1 each.
Model Article Code	5130861700
Model Description-1	KSE-45 Anti-vibration Mounts.
Model Description-2	Anti-vibration mounts for isolating potential vibrations from CVAT fans. Supplied x4 per pack.
Model Article Code	5401304100
Model Description-1	REB-CVF (Remote Mount Speed Control)
Model Description-2	Remote mounted, single-gang size, ON/OFF switch and infinitely variable speed controller. Suitable for use when either VFD is too

	large or client requires smaller, more aesthetic, controller located at kitchen level.
Model Article Code	L100000681
Model Description-1	Cook Prep Switch.
Model Description-2	Simple ON/OFF, and High/Low fan speed control functions. High/Low speeds defined at VFD as needed.

Dimensions	A	B	C	D	E	F	H
1400 250ND	500	457	574	250*	58	534	250
2000/315ND	500	457	574	315*	58	534	250
3000/355 ND	650	607	724	355*	58	684	325
4000/400 ND	650	607	724	400*	58	684	325
6000/450 ND	750	707	824	450*	58	784	375
6000/500 ND	650	607	724	500+	58	684	325
9000/500 ND	800	757	874	500*	58	834	400
12000/560 ND	900	826	977	560*	58	937	450
16000/630 ND	1000	959	1077	630*	58	1037	500
15000/710 ND	1100	1059	1177	710*	58	1137	550

DIMENSIONS (mm)

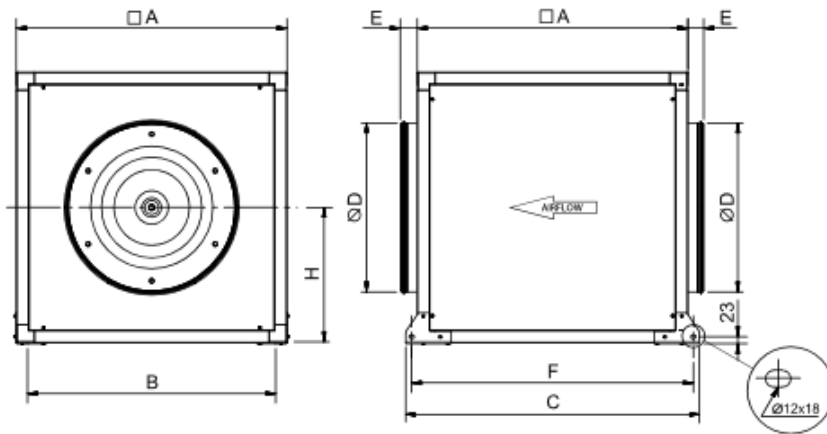

* □ 6000/500 ND

