

Switchmaster 800 Series

SM300, SM400, SM600, SM805

Features

- 24 hour programme
- CONSTANT/TIMED/OFF switching options
- Colour coded tappets (once or twice switching)
- Double insulated
- **SM300:** suitable for combi boilers – volt-free contacts
- **SM400, SM600:** Suitable for gravity or fully pumped systems
- **SM805:** Suitable for fully pumped systems

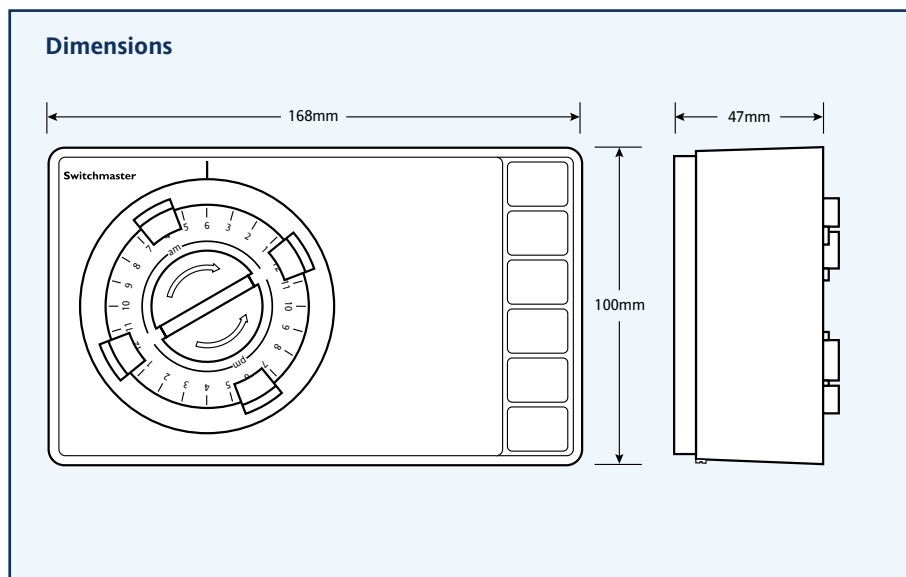

Wiring connections

SM300

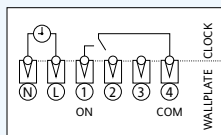

SM400

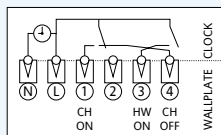

SM600

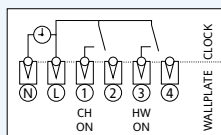

SM805

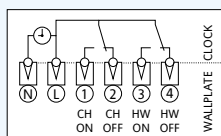

Technical data

Voltage	230v 50Hz
Rating	5 (2) A – all models
Ambient temperature	Operating: 0°C to 45°C Storage: -20°C to 50°C
Programme resolution	90 minutes
Wiring	Designed for fixed wiring only, to comply with current IEE regulations
Maintenance	No user maintenance should be attempted



Invensys Climate Controls Limited
Cordwallis Street, Maidenhead
Berkshire SL6 7BQ

Telephone: +44 (0)1628 546200
Sales Facsimile: +44 (0)1628 673319
Technical Helpline: +44 (0)1628 546222
Website: www.climate-eu.invensys.com

An Invensys Company

AVAILABLE FROM:

