

BEDLAM TONECALLER BASE PCB

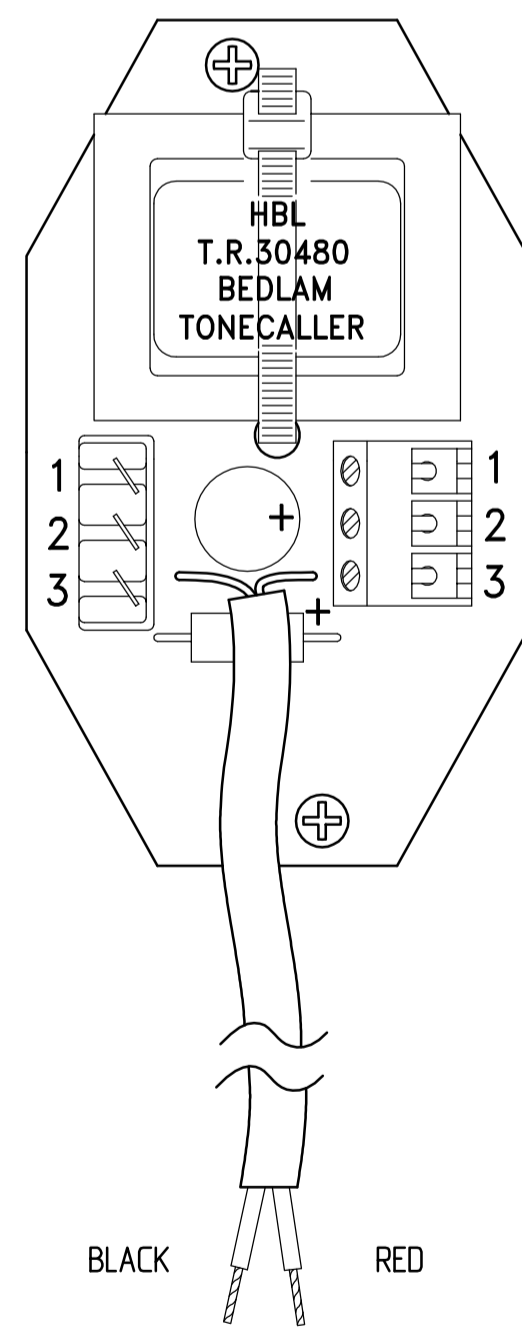

MASTER SOCKET

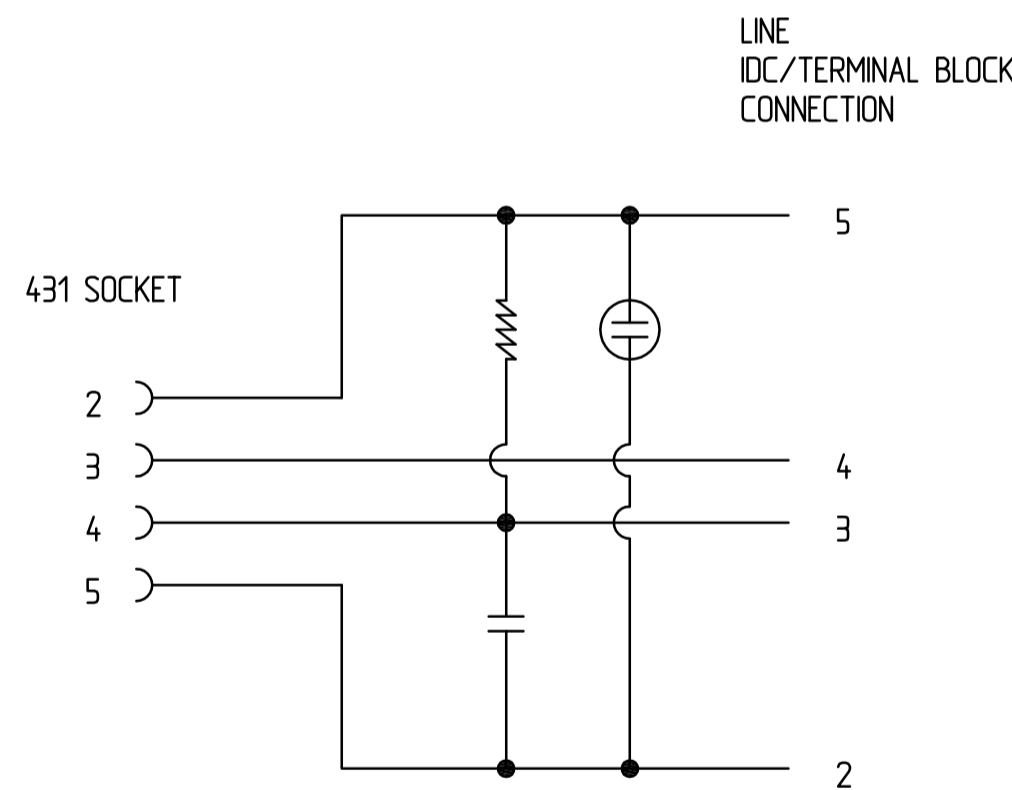

NOTE:

(D) DOMESTIC VERSION FITTED WITH LINE CORD/431 PLUG

The Bedlam Loud Tonecaller is for use in office or factory areas with high background noise level. The Tonecaller will emit a loud sound in sympathy with the ringing signal, and will be silent at all other times.

It is supplied with a cable gland suitable for normal 6-wire cable used by telephone installers (5-7 mm OD). The (D) Domestic version is pre wired to a line cord fitted with 431 plug. The (T) Trade version intended to be hardwired to the telephone system by an engineer responsible for the system.

For Direct Exchange Lines and Private Branch Exchanges (PBX) run by British Telecom, the installation should be done by British Telecom engineers. For other PBX, the installation should be done by the company responsible for the system installation and maintenance.

The unit must be connected in parallel with other approved apparatus where calls may be answered when a ringing indication is given.

It is factory set to maximum sound output and close proximity could result in hearing damage, therefore it should not be mounted within 3 metres of persons using the area.

The Tonecaller should be mounted high up on a secure wall with the Tonecaller nose facing the direction that the sound is to be projected. The unit should be mounted on a vertical wall or upside down from an overhang.

Never mount the Tonecaller with the nose facing upwards, since it would then collect dust and/or water and may suffer failure.

Installation

- Fix the base unit (2) to a suitable surface via the four 5 mm holes provided.
- On (T) unit, pass one end of the 6-wire cable through the cable gland, after first loosening the outer clamp nut. Then terminate two wires of the 6-wire cable to the screw terminals (6) marked 2 and 3 or the Insulation Displacement Connector (IDC) (7) pins 2 and 3. Now tighten the outer clamp nut of the cable gland onto the cable to secure it.
- Take the nose unit, the four long screws (3) and rubber gasket (4), pass the two wires from the base unit through the plastic sleeve and rubber gasket and terminate them in the terminal block (5) in the rear of the nose. Red wire to +ve and the other wire -ve.
- Screw the two halves together using the four long screws. Make sure that the gasket is in position and the wires are not trapped.
- Complete the cable run back to the nearest telephone master or secondary socket using standard installation practice and terminate the free end of the cable to the socket terminals as follows.

Base Unit Terminal	Line IDC/Terminal Block
2	5
3	3

- If the sound output from the tonecaller is too loud, the level may be adjusted by turning the volume adjuster in the nose part, in the direction shown on the circuit box label. Disconnect the unit from the socket terminals before opening the unit for output adjustment, as hazardous voltages may exist inside if the unit is left connected to the line.

The Bedlam Loud Tonecaller is tested and approved for connection to the telephone network, providing it is used according to the guidelines given.

It may be connected to the following types of installation:

- Direct Exchange Lines.
- Extensions with new plan (plug and socket) arrangements provided with these direct exchange lines.
- Compatible switchboards.

It may not be connected to share service (party lines)

It may not be used as an extension to payphone.

Your exchange line provides only a small current to make it ring. Although you may have a number of sockets, it is important to limit the number of phones or Tonecallers connected to the line to ensure that each device will ring.

Every phone or Tonecaller will have a Ringer Equivalence Number or REN. In most cases a standard line should provide enough current for two or more phones or Tonecallers whose RENs add up to no more than 4.

The Bedlam Loud Tonecaller has a REN of 1.5.

Even where the number of phones or tonecallers has been limited there is no guarantee that different types of phones on the same line will ring.

A			G.D.	18/05/05
ISS	REVISION	CHANGE	INT.	DATE

REMOVE BURRS & SHARP EDGES

ALL DIMENSIONS ARE IN MM

MATERIAL	METRIC TOLERANCES UNSPECIFIED	DRAWN	G.D.	INSTALLATION GUIDE BEDLAM LOUD TONECALLER
FINISH	± 0.1 Dim to 2 dec places	CHECKED		
	± 0.2 Dim to 1 dec place	APPROVED		
	± 2 *Angular	SCALE	N/S	
		ZERO DEFECTS	DRG. NO.	81523
				ISS No. A1