

5W LED Energy Saver Bulkhead

Model: LED88 – Black

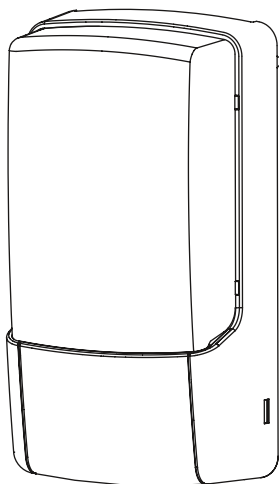

Installation & Operating Instructions

1. General information:

Parts Included

- Luminaire unit.
- Instruction manual. Please keep safe for future reference.
- Accessory pack.

Tools & Parts Needed

- Electric or hand-held drill & bits.
- Terminal or electricians screwdriver.
- Flat and philips screwdriver.
- Wire cutters.

2. Selecting the location:

Unit is for indoor and outdoor use. Unit must be mounted on a non-flammable surface as a fixed luminaire, and is not suitable for portable use.

The unit can get very hot during use. Ensure the unit has cooled before handling.

Ensure adequate ventilation space is allowed between the unit and any object above, in front or to either side of the unit. Suggested space is 0.5m above, 0.3m to either side & 1.0m in front.

3. Installation:

After choosing a suitable location (see previous section) install the unit as follows:

IMPORTANT

Switch off the electricity at the fuse box by removing the relevant fuse or switching off the circuit breaker before proceeding with the installation.

We recommend this unit be fitted by a qualified electrician. Install in accordance with wiring and current building regulations. Please read the instructions carefully.

The unit is suitable for connection to a 230 V AC 50Hz electricity supply. It is suggested that 3-core round flexible cable of 1mm² gauge is used. An isolating switch should be installed to switch the power to the unit ON & OFF. This is for maintenance purposes.

Loosen up the bottom screw (Fig A). Remove wall plate by using a small flat screwdriver (Fig A) by gently easing the wall plate outwards.

Open the rubber plug, mark position of the fixing holes (Fig B). Drill the holes. Insert the wall plugs into the holes.

Pierce the grommet and pass the cable through the grommet.

Clamp the cable to the rear of the unit before securing the unit to the wall.

Fit grommet into its location hole ensuring a good seal.

Fix the unit to the wall (Fig C). Close the rubber plug after tightening the screws (Fig E). Attach the unit to the wall plate by a sound of click, tighten the bottom screw (Fig D). If using a power screwdriver, use the lowest torque setting.

2

Close the rubber plug after tightening the screws.

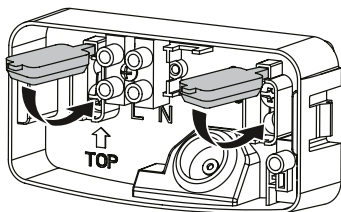

E

Connection

Connect the cable to the terminal block as follows (see connection diagram):

LIVE (Brown)	L
NEUTRAL (Blue)	N
EARTH (Green/Yellow)	

Ensure the connections are secure. Refit wall plate ensuring it clicks firmly into place.

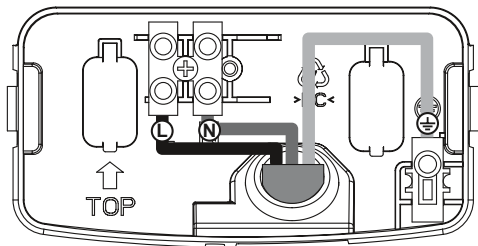

3

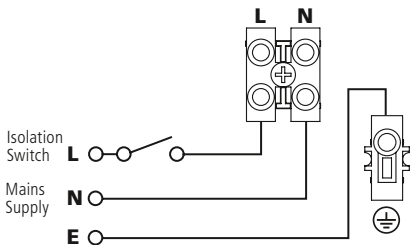

4. Operating and testing:

Turn the power to the unit ON and the unit will illuminate.

5. Technical specifications:

Energy Efficiency	Class A+
Energy Usage	6kWh/1000h
Output	310lm typical
Lamp Beam Angle	90x90 degrees The lamps are not replaceable in this product
Power Supply	230 V AC ~ 50Hz
Lamp Type	5W LED which is the equivalent light output of a 70W Halogen Lamp
Environmental Protection	IP55 (suitable for outdoor use)
EC Directives	Conforms to current EC Directives

**If you experience problems refer to Troubleshooting Guide.
If problems still exist, do not immediately return the unit to store.
Telephone the Timeguard Customer Helpline**

020 8450 0515

**Qualified Customer Support Co-ordinators will be on-line to assist
in resolving your query.**

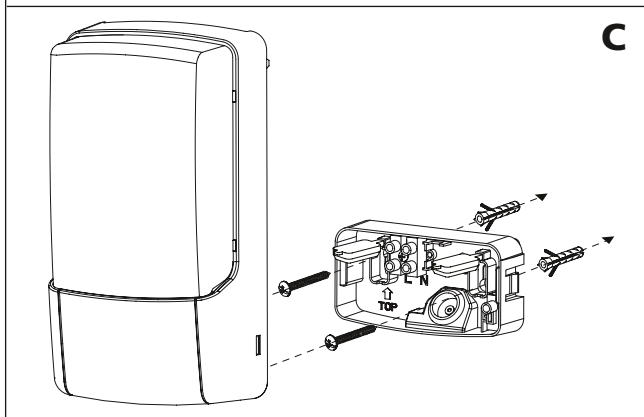
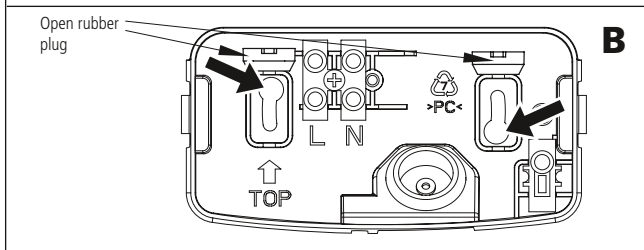
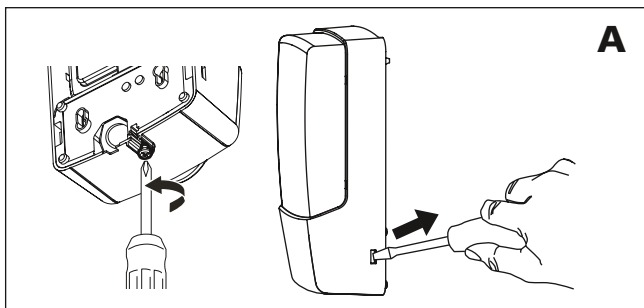

6

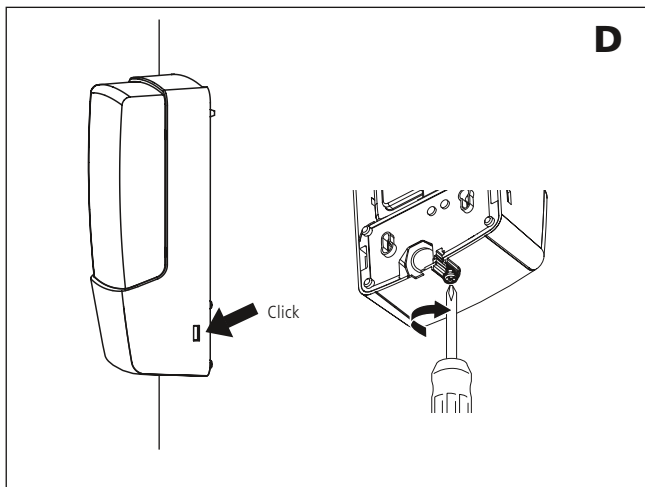

3 Year Guarantee

In the unlikely event of this product becoming faulty due to defective material or manufacture, within 3 years of the date of purchase, please return it to your supplier in the first year with proof of purchase and it will be replaced free of charge. For years 2 to 3 or any difficulty in the first year telephone our helpline on **020 8450 0515**.

Note: A Proof of Purchase is required in all cases. For all eligible replacements (where agreed by Timeguard) the customer is responsible for all Shipping/Postage charges outside of the UK. All Shipping costs are to be Paid in advance before a replacement is sent.

For assistance with the product please contact:

HELPLINE

020 8450 0515

or email helpline@timeguard.com



For a product brochure please contact:

Timeguard Limited.

Victory Park, 400 Edgware Road,

London NW2 6ND

Sales Office: 020 8452 1112

or email csc@timeguard.com

A **theben**® Group Company

67.058.493 (issue 1)