

Programa*stat*

Electronic Room Thermostat

Cat. No. TRT030



Operating & Installation Instructions



A **theben** Group Company

What is a room thermostat? ... an explanation for householders

A room thermostat simply switches the heating system on and off as necessary. It works by sensing the air temperature, switching on the heating when the air temperature falls below the thermostat setting, and switching it off once this set temperature has been reached.

Turning a room thermostat to a higher setting will not make the room heat up any faster. How quickly the room heats up depends on the design of the heating system, for example, the size of boiler and radiators.

Neither does the setting affect how quickly the room cools down. Turning a room thermostat to a lower setting will result in the room being controlled at a lower temperature, and saves energy.

The heating system will not work if a time switch or programmer has switched it off.

The way to set and use your room thermostat is to find the lowest temperature setting that you are comfortable with, and then leave it alone to do its job. The best way to do this is to set the room thermostat to a low temperature – say 18°C – and then

turn it up by one degree each day until you are comfortable with the temperature. You won't have to adjust the thermostat further. Any adjustment above this setting will waste energy and cost you more money.

If your heating system is a boiler with radiators, there will usually be only one room thermostat to control the whole house. But you can have different temperatures in individual rooms by installing thermostatic radiator valves (TRVs) on individual radiators. If you don't have TRVs, you should choose a temperature that is reasonable for the whole house. If you do have TRVs, you can choose a slightly higher setting to make sure that even the coldest room is comfortable, then prevent any overheating in other rooms by adjusting the TRVs.

Room thermostats need a free flow of air to sense the temperature, so they must not be covered by curtains or blocked by furniture. Nearby electric fires, televisions, wall or table lamps may prevent the thermostat from working properly.



Certification mark

1. Introduction

TRT products are a cost effective comprehensive range of thermostats and timers designed for internal use only.

The TRT030 is an electronic room thermostat, with an easily adjustable dial. It has optional PID control (which can help to minimise temperature overshoot), and adjustable swing (difference between on and off switching temperatures), from 1°C to 0.5°C.

It is designed to be surface mounted on its supplied wall plate.

The electrical supply **must** be isolated before removing the thermostat from the wall plate.

TRT030 Electronic Room Thermostat

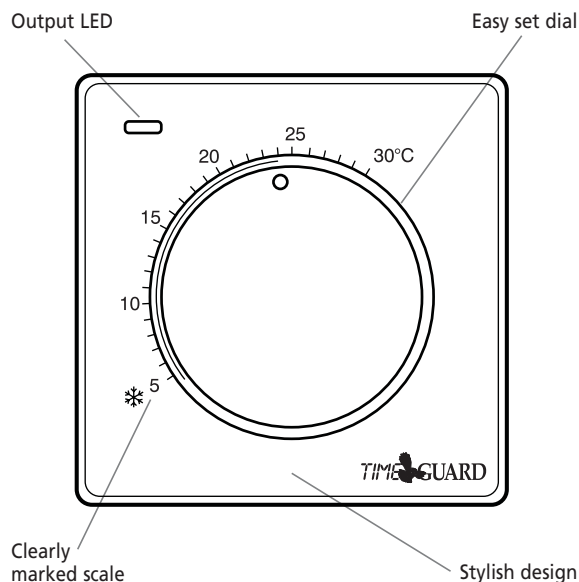

Fig. 1

Rear View of TRT030 (without mounting plate)

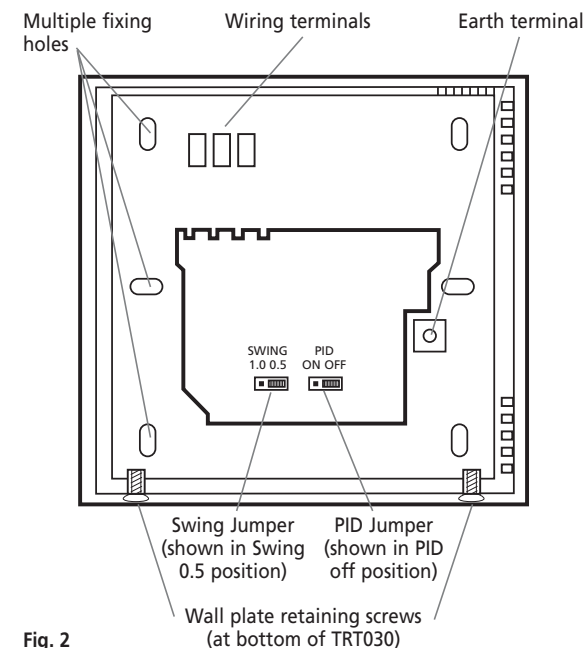

Fig. 2

Contents

TRT030 thermostat
TRT030 instruction
leaflet

TRT030 wall plate
2 x wall plugs
2 x screws

2. Siting

The TRT030 must be sited where it will not be influenced by heat sources, for example above a radiator or a television or in direct sunlight or subjected to draughts.

The product requires air circulation, so do not position above or below shelving or other wall mounted obstacles.

It should be mounted approximately 1.5 meters above floor level.

3. Installation

This product must be installed in accordance with the appropriate building and wiring regulations.

In all cases if there is a doubt as to how to proceed with an installation consult a qualified electrician, your local authority's building control department or the Timeguard helpline (020 8450 0515).

The TRT030 is designed to be surface mounted on the supplied wall plate (Fig. 4).

Always isolate the mains supply before removing the unit from its wall plate.

Isolate 230VAC mains supply.

Incoming and outgoing wires should be 1.5mmsq.

Remove wall plate from unit, by undoing retaining screws (see Fig 2), and pivoting the bottom of the unit outwards. The TRT030 can then be lifted off.

Pass the incoming wires through the opening in wall plate, and fix wall plate securely to the wall, using the screws provided (and wall plugs if necessary) provided. The screws which secure the product to the wall plate should be at the bottom (see Fig 2).

Allow sufficient excess cable to wire up the unit, but not too much to make it difficult to close the unit to the wall plate.

Connect the conductors to the relevant terminals, according to the wiring diagram on the wall plate (or Fig. 3 below). Ensure that the curved brass washer grips the conductor.

Wiring Diagram

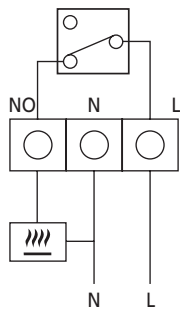

Fig. 3

Back Plate Removed

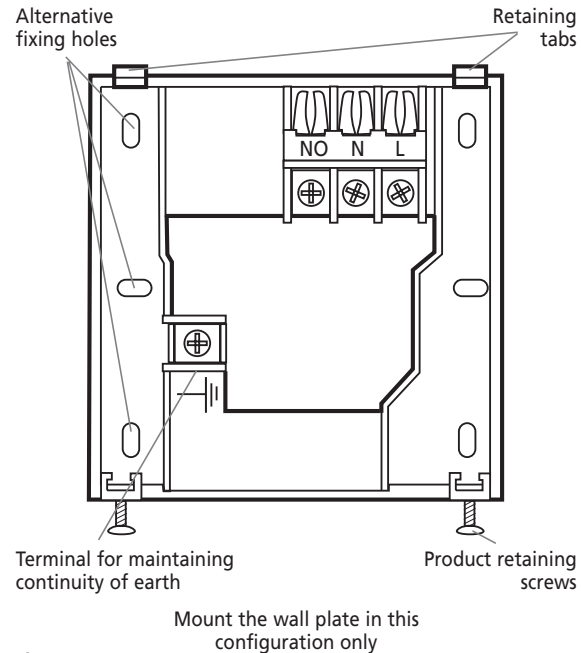

Fig. 4

This unit is double insulated, and hence does not need connection to earth. If earth continuity is required, please use earth terminal on wall plate.

To reinstall the unit on the wall plate first ensure the wall plate retaining screws are loosened enough to clear the TRT030 body then engage the top of the TRT030 onto the wall plate retaining tabs (see Fig 4), and push firmly downwards and then upwards. There will be some resistance from the terminals. Once in place, secure with the retaining screws.

Restore mains to the unit after checking all system wiring is complete.

4. Operation

Use adjuster dial to set desired temperature.

Blue LED is lit when temperature is below desired value, indicating that the thermostat is calling for heat from the boiler. Once the room reaches the desired temperature the LED turns off and the TRT030 ceases to call for heat from the boiler.

The temperature swing can be adjusted between 1°C and 0.5°C by selecting a jumper found on the rear of the unit (see Fig 2).

We suggest using the 0.5°C position unless the boiler turns on and off too rapidly.

PID can also be selected on or off using a jumper on the rear of the unit (see Fig 2).

This can help in reducing temperature over-shoot. We suggest using the PID on position.

To clean use a clean dry cloth only. Do not use any liquid cleaners.

5. Specifications

| | |
|------------------------------|----------------------------------|
| Current rating: | 10 (2) A |
| Voltage: | 220-240V, 50HZ |
| Switch type: | Single pole, single throw (SPST) |
| Operating temperature range: | 0 to 50°C |
| Set temperature range: | 5 to 30°C |
| Complies with: | BS EN 60730 |
| Conforms to directives: | 73-23-EEC, 89-336-EEC |
| Temperature swing: | 1°C or 0.5°C |
| Micro disconnection: | Type 1.B control action |

For assistance with the product please contact:-

HELPLINE

020-8450-0515

or email helpline@timeguard.com



3 Year Guarantee

In the unlikely event of this product becoming faulty due to defective material or manufacture within 3 years of the date of purchase, please return it to your supplier in the first year with proof of purchase and it will be replaced free of charge. For years 2 and 3 or any difficulty in the first year telephone the helpline on **020 8450 0515**.

For a product brochure please contact:

Timeguard Ltd. Victory Park, 400 Edgware Road,

London NW2 6ND Tel: 020-8452-1112

or email csc@timeguard.com

A **theben** Group company

67-058-322