

TRITON

**· Aquasensation AS2000T / AS2000
thermostatic and manual power shower ·**



Installation and Operating Instructions

INSTALLERS PLEASE NOTE THESE INSTRUCTIONS ARE TO BE LEFT WITH THE USER

CONTENTS	Page
Plumbing and electrical notes	1
Introduction	2
Safety warnings	2
Key to main components	3
Specifications	3
Site requirements - water	4
General installation notes	5
Siting of the shower	6
Removing the cover	7
Plumbing connections	7 - 9
Fitting the shower to the wall	10
Electrical connections	11
Commissioning and setup procedure	12 - 13
Temperature control spindle setting	14
Fitting the riser rail	15
Fitting the soap dish and sprayhead	16
Operating the shower	17
Adjusting the sprayhead	18
Adjusting the maximum temperature stop	19
Cleaning – shower and sprayhead	20
Cleaning – filters	21
Spare parts	22 - 23
Fault finding	24
Guarantee, service policy, etc.	rear cover

To ensure the product suitability for commercial and multiple installations, please contact Triton's specification advisory service prior to installation.

Telephone: 02476 325491

Facsimile: 02476 324564

E mail: reception@triton.plc.uk

1 PLUMBING NOTES

- 1.1** All installations must comply with the Local Water Company or Water Undertakers Byelaws.
- 1.2** Supply pipes must be flushed to clear debris before connecting the shower unit (Byelaw 55).
- 1.3** DO NOT connect the shower unit to the mains cold water supply as it would damage the unit and also, the installation would be in breach of the guidance notes contained in 1.1 above.
- 1.4** DO NOT use excessive force when making connections to the flexible hose or sprayhead – finger tightness is sufficient.
- 1.5** DO NOT turn on the electrical supply until the plumbing connections have been completed. Only then can the electricity be switched on in order to power the solenoid to turn water on to the shower when commissioning. *The shower must not be operated dry without water.*
- 1.6** DO NOT solder pipes or fittings within 300mm of the shower appliance, as heat transfer can damage components.
- 1.7** When installed, the top of the shower unit must be at least 75mm lower than the base of the cold water storage cistern to prevent the pump being run dry without water.
- 1.8** A dedicated cold water supply must be taken directly from the cold water cistern to the shower. This draw-off must be on the opposite side of the cistern to the float operated valve.
- 1.9** The action of the pump is to increase the flow rate. If the supply pipework cannot handle the resulting flow rate then:-
- 1.9.1)** The anticipated flow rate may not be achieved.
- 1.9.2)** Air may be drawn into the hot supply from the vent pipe causing spluttering and temperature fluctuations at the sprayhead.
- 1.10** A high level hot feed pipe run will result in air locking and must be avoided.
- 1.11** Standard gate valves MUST be fitted on the hot and cold water supplies to the shower as

an independent means of isolating the water supplies should maintenance or servicing be necessary. DO NOT use stop taps or ball-o-fix type valves which restrict flow.

- 1.12** If the shower unit is installed on a common supply which feeds an adjacent tap, the maximum static inlet pressure for the unit will, under certain circumstances be exceeded. The action of closing the tap can cause a pulse in the supply pressure which will result in damage to the unit. This can be resolved by the installation of a suitably sized mini expansion vessel, sited as close as possible to the tap and pressurised to 0.5 bar.

2 ELECTRICAL NOTES

- 2.1** The installation must comply with BS 7671 'Requirements for electrical installations' (IEE wiring regulations) and Electrical Supply Company regulations. Ensure the incoming hot and cold water supplies to the shower are adequately earth bonded.
- 2.2** DO NOT turn on the electrical supply until the plumbing connections have been completed. Only then can the electricity be switched on in order to power the solenoid to turn water on to the shower when commissioning. *The shower must not be operated dry without water.*
- 2.3** The mains supply must be 230/240V, at 50Hz, connected to the unit via a double pole switched 3 Amp fused connection unit (not supplied) with a minimum 3mm contact separation gap in each pole.
- 2.4** In accordance with 'The Plugs and Sockets etc. (Safety) Regulations 1994', this unit is intended to be permanently connected to the fixed electrical wiring of the mains system.
- 2.5** Fuses do not give personal protection against electric shock.
- 2.6** It is strongly recommended to fit a 30mA residual current device (RCD). This may be part of the consumer unit or a separate unit.

INTRODUCTION

This book contains all the necessary fitting and operating instructions for your Triton Aquasensation thermostatic or manual power shower. Please read them carefully.

Please note that both models outwardly are similar. The thermostatic version – AS2000T is only identifiable by having ‘thermostatic’ graphic on the cover, above the controls. The manual AS2000 shower does not have this graphic and does NOT contain a thermostatic valve. Some illustrations in this book depict the thermostatic model but the instructions will apply to both models, unless otherwise stated.

The shower installation must be carried out by suitably competent person and in sequence of this instruction book. Care taken during the installation will ensure a long and trouble free life from your shower

Important: All plumbing connections must be completed BEFORE making the electrical connections.

Please read through the whole of this book before beginning your installation.

Important: The fittings on the pipe inlet elbows are of the push-in type. The pipework must be cut with a pipe cutter and all burrs and rough edges removed from the end of the tube. The fittings can be used with copper and plastic pipe. Where chrome plated pipe is used, remove the first 25mm of plating.

NOTE: The pump inside this product is rated 15 minutes on / 45 minutes off duty cycle.

Due to continuous improvement and updating, specification may be altered without prior notice.

SAFETY WARNINGS

- 1 Do not insert fingers into the push-in inlet fittings. Doing so could cause injury.
- 2 **Under no circumstances must this product be connected to mains cold or hot water supplies.** Failure to comply will invalidate the guarantee.
- 3 The shower MUST NOT be used if suspected of being frozen.
- 4 The outlet of this appliance must not be connected to any form of tap or fitting not recommended by the manufacturer.
- 5 The sprayhead cartridge must be cleaned regularly to remove scale and debris.
- 6 This appliance must be earthed.
- 7 Switch off immediately at the isolating switch if water ceases to flow during use.
- 8 If it is intended to operate the shower outside the guidelines laid out in the site requirements, see NOTE below.

NOTE: In the event of items 3, 7 and 8, contact Triton Customer Service for advice. Tel: 02476 372222.

WARNING: The manual AS2000 shower does not contain a thermostatic valve – it will not shut off in the event of failure of either the hot or cold water supplies.

Replacement parts can be ordered from Triton Customer Service. See ‘*spare parts*’ for details and part numbers.

In the interest of electrical safety a 30mA residual current device (RCD) should be installed in all UK 230V electric and pumped shower circuits. This may be part of the consumer unit or a separate unit.

KEY TO MAIN COMPONENTS

- 1 Top pipe entry and cable entry
- 2 Terminal block
- 3 Cable clamp
- 4 Cover screw fixing
- 5 Motor cover
- 6 Rear pipe entry and cable entry
- 7 Wall fixing holes
- 8 Pipe inlet elbow - top (contains single check valves)
- 9 Filter cover - top
- 10 Pump
- 11 PCB housing
- 12 Setting adaptor
- 13 Temperature control valve
- 14 Solenoid
- 15 Filter cover - bottom
- 16 Pipe inlet elbow - bottom (contains single check valves)
- 17 Outlet
- 18 Bottom pipe entry

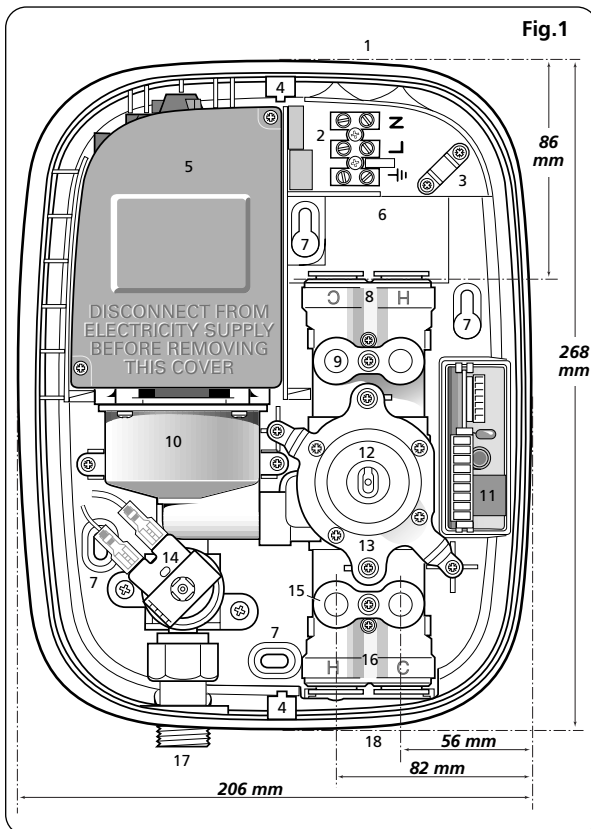

SPECIFICATIONS

Hot water temperature

Maximum temperature 80°C. BS6700 recommends that the temperature of stored water should never exceed 65°C. A stored water temperature of 60°C is considered sufficient to meet all normal requirements and will minimise the affects of scale in hard water areas.

Temperature control (Thermostatic only)

To obtain the maximum performance, this unit should be installed, operated and maintained as instructed in this book. The full performance specification as below for the standard unit is achieved with a blend set between 35°C – 40°C and supplies of 15°C cold and 65°C hot with nominally equal pressures.

1) The blended water temperature is maintained within 2°C with a 10°C change in the hot and cold water supply.

2) The sensor effects a shut down to seepage in approximately 2 seconds if the cold supply fails.

3) Shut down to seepage is achieved even if the hot supply is only 12°C above the blend temperature.

4) The blended water temperature is maintained within 1°C when the pressure between inlet and outlet is halved (defined as a pressure loss ratio of 2:1) on either the hot or cold side.

Maximum static inlet pressures

1 bar or 10m (supplies must be gravity fed at nominally equal pressures).

Minimum static inlet pressure

0.0075 bar or 75mm (required to prime the integral centrifugal pump).

SITE REQUIREMENTS

Water

The installation must be in accordance with Local Water Company Byelaws and BS6700.

For correct operation of this shower unit, both hot and cold water supplies to the appliance must be gravity fed, at nominally equal pressures, from a cold water storage cistern and a hot water storage cylinder. The water circuit should be installed so that the flow is not significantly affected by other taps and appliances being operated elsewhere on the premises.

Fig.2 shows a recommended installation where the hot water supply for the shower is made via a tee connection on the underside of the rising horizontal section of pipework from the cylinder. Alternatively, the

connection can be taken from the hot supply pipe to other outlets as long as it is the first draw-off below the ventilation pipe tee.

Fig.3 illustrates all the incorrect connections that must be avoided.

All pipework to the shower unit must be routed where it remains below the level of water in the cistern. In the case of horizontal sections of pipework in lofts, it may be necessary to fit automatic air vents at high points on the supplies to remove the possibility of air locks.

For the operation of the shower only, it is recommended that the cold water storage cistern is capable of holding at least 114 litres (25 gallons). Where other hot and cold

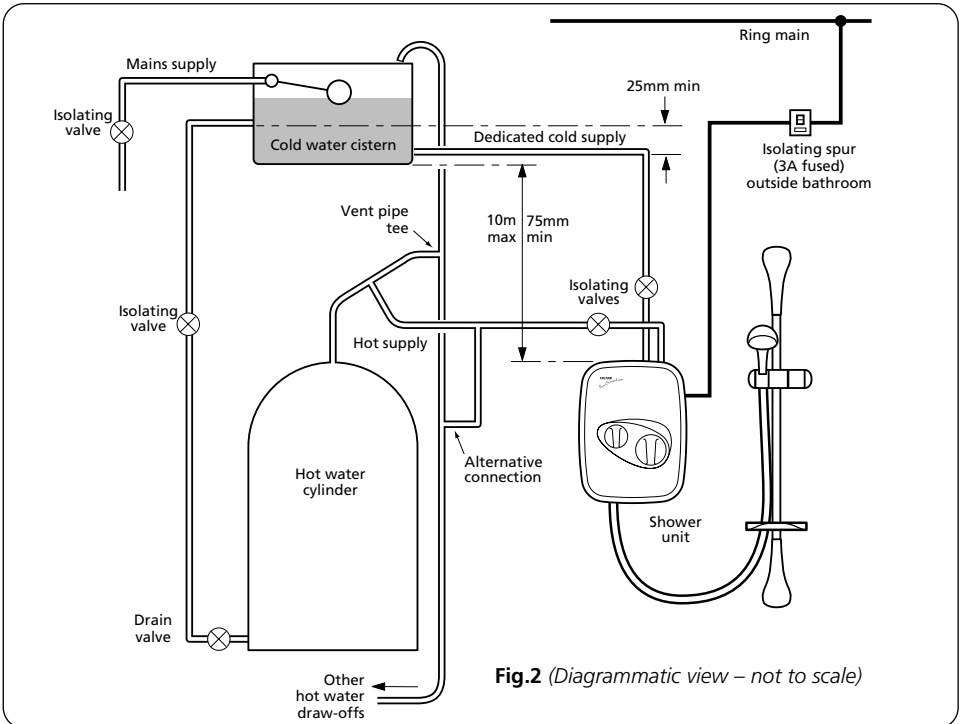

Fig.2 (Diagrammatic view – not to scale)

outlets are likely to be in use simultaneously, the storage capacity should be increased to 228 litres (50 gallons) in accordance with BS6700.

Do ensure compliance with all the local Water Company Byelaws.

DO NOT connect to a combination cylinder unless there is a guaranteed 114 litre cold supply to the cylinder as the shower can deliver up to 14 litres per minute. It is advisable to check that the infill rate from the float operated valve meets the output requirements..

It is recommended that there is a minimum of approximately 114 litres (25 gallons) of hot water storage per appliance.

The shower MUST NOT be connected to the mains cold water supply.

DO NOT use jointing compounds.

GENERAL INSTALLATION NOTES

- 1 DO NOT take risks with plumbing or electrical equipment.
- 2 DO NOT install this unit in a position where it could become frozen.
- 3 Isolate electrical and water supplies BEFORE proceeding with installation work.
- 4 Shower control MUST be fed from a cold water storage cistern and hot water cylinder that provides nominally equal pressures.
- 5 The unit must be mounted onto the finished wall surface (on top of tiles). DO NOT tile up to the unit after fixing to the wall.
- 6 If installing with rear inlet supplies, it is recommended the supply pipework is sealed

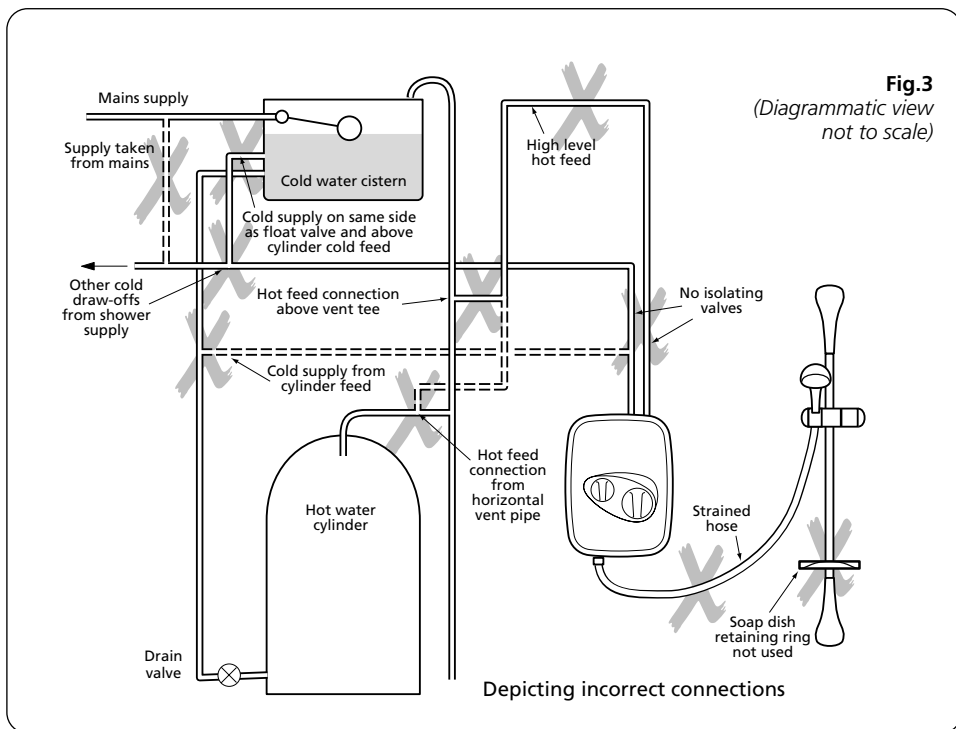

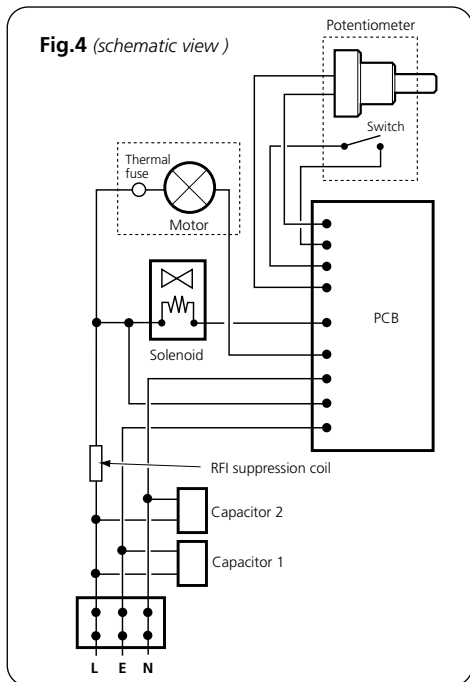

to the wall so as to prevent water from leaking back into the wall.

7 In solid wall installations, the supply pipework should be housed within ducting in order to allow some free lateral movement when making connections and to ensure compliance with requirements of Byelaw 58 (accessibility of pipes and pipe fittings).

Fig.4 shows a schematic wiring diagram of the unit.

SITING OF THE SHOWER

WARNING: THE SHOWER MUST NOT BE POSITIONED WHERE IT WILL BE SUBJECT TO FREEZING CONDITIONS.

FOR EASE OF SERVICING, THE APPLIANCE MUST ALWAYS BE MOUNTED ON THE SURFACE OF TILED WALLS. NEVER TILE UP TO THE APPLIANCE.

Refer to fig.5 for correct siting of the shower. Position the appliance vertically where it will NOT be in direct contact with water from the sprayhead.

NOTE: Allow sufficient room between the ceiling and the shower unit to access the top cover screw.

Position the shower and sprayhead on the wall so that all controls can be comfortably reached whilst using the shower.

The sprayhead and riser rail can be positioned either side of the shower unit.

NOTE: Water supply Byelaw 17 (shower hose connections) requires that the sprayhead be 'constrained by a fixed or sliding attachment so that it can only discharge water at a point not less than 25mm above the spill-over level of the relevant bath, shower tray or other fixed appliance'.

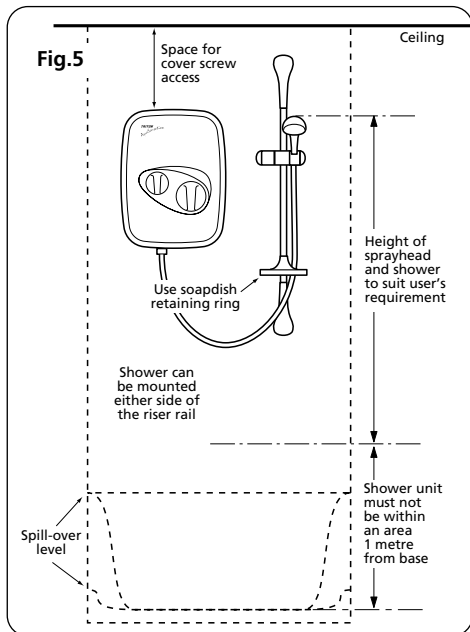

REMOVING THE COVER

To remove the cover, first pull off the temperature control only (fig.6) – *not the flow control*.

This will reveal the maximum temperature stop (fig.7). This should be left in position.

NOTE: If adjustment of the maximum temperature stop is required, refer to section 'Adjusting the maximum temperature stop'.

Remove the two cover fixing screws – top and bottom (fig.8).

Carefully lift the cover away from the backplate. Lay aside the cover and screws until the unit is fully installed.

NOTE: When removing the cover for future maintenance purposes etc., be aware of the lead connected to the PCB unit. Carefully pull off the lead from the PCB. Do not let the cover dangle by the lead.

PLUMBING CONNECTIONS

Plumbing to precede wiring

NOTE: The outlet of the shower must not be connected to any tap or fitting not recommended by Triton Plc.

DO NOT use jointing compounds on any pipe fittings for the installation.

When connecting pipework avoid using tight 90° elbows. Swept or formed bends will ensure optimum performance.

Isolate the mains water supply to the cold water cistern. Drain the hot and cold pipes by opening all taps.

The hot water supply can be taken from the hot supply pipe from the cylinder, ensuring that it is the first draw-off below the ventilation pipe tee in order to minimise the effects of water draw-off elsewhere in the house (see fig.2).

NOTE: There must not be any other draw-offs between the take-off point and the shower.

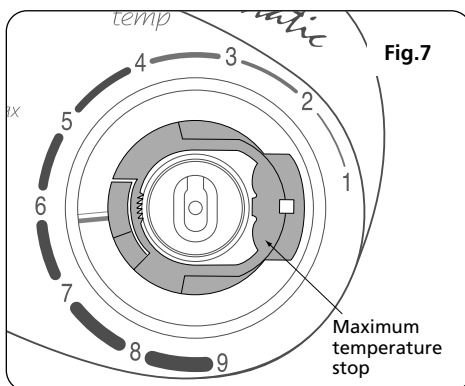
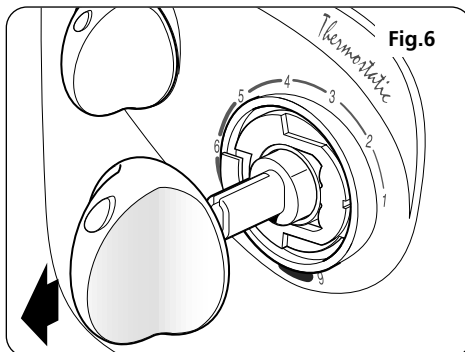

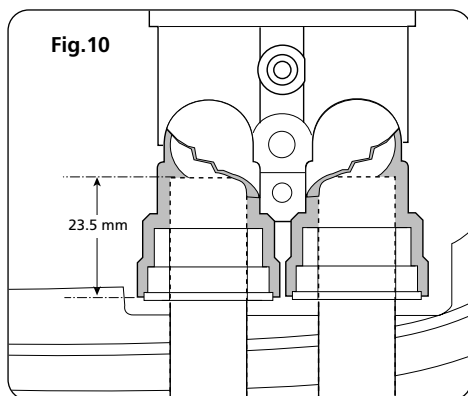
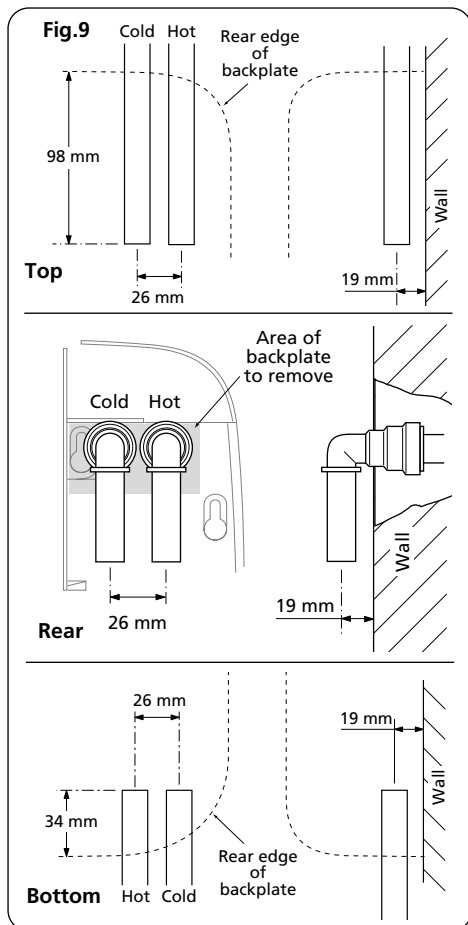

A dedicated cold water supply must be taken directly from the cold water cistern to the shower. This draw-off must be positioned 25mm below the cold feed connection to the hot water cylinder on the opposite side of the cistern to the float operated valve (see fig.2). This minimises air ingress into the pipework.

Plumbing options other than those outlined in these fitting instructions could impair the performance. For example, if hot and cold connections are made after draw-off points to other outlets, (eg. washing machine, taps, etc.) it could result in unstable flows and temperatures should other appliances operate at the same time.

Run the hot and cold pipework to the shower position ensuring that the pipework does not rise above the level of water in the cold cistern at any point to avoid air locks. Under normal site conditions 15mm pipework will be adequate.

Decide the position of the shower. Cut the pipework to the dimensions relevant to the chosen direction of water entry into the shower.

Important: For rear entry only, the supplied elbows must be used. For ease of installation, the backplate area adjacent to the top pipe inlet must be cut out, including the top left wall fixing hole.

When fitting the elbows to incoming pipework, ensure the elbow collets are fully engaged with the pipe.

Dimensions are shown in figs.9 and 10.

NOTE: The pipe inlets are marked for hot and cold connections – left side for hot inlet on bottom entry (fig.11), but right side for hot inlet on top or rear entry (fig.12).

Important: The fittings on the inlet elbows are the push-in type. The pipework must be cut with a pipe cutter and all burrs and rough edges removed from the end of the

tube. The fittings can be used with copper and plastic pipe.

If using chrome plated copper pipe, remove the first 25mm of plating completely from the connecting surfaces. If not completely removed then the collet will not grip the pipe and under pressure the pipe may be forced out

NOTE: Pipework must be clipped or fixed to the wall so that it cannot be moved or removed without the aid of a tool.

NOTE: The pipe inlets contain filters. These should be periodically removed and cleaned in order to maintain the performance of the shower. See section 'cleaning' on how to access the filters.

Important: The inlets contain check valves, so before completing the connection of the water supplies to the shower flush out the pipework to remove all swarf and system debris that may cause damage to internal parts. This can be achieved by connecting a hose to the pipework and turning on the water supplies long enough to clear the debris to waste (Byelaw 55).

Two factory fitted blanking plugs are fitted to the top pipe inlets. These should be left in position if bottom pipe entry is required. But for top or rear pipe entry, the two plugs must be removed and re-fitted into the bottom pipe inlets.

Insert the pipe removal tool supplied between the flange of the plug and the grey collet and lever the plug outward (fig.13). Whilst holding back on the collet, pull out each plug by hand. When re-fitting the plugs in the bottom pipe inlets, ensure they are pushed fully home.

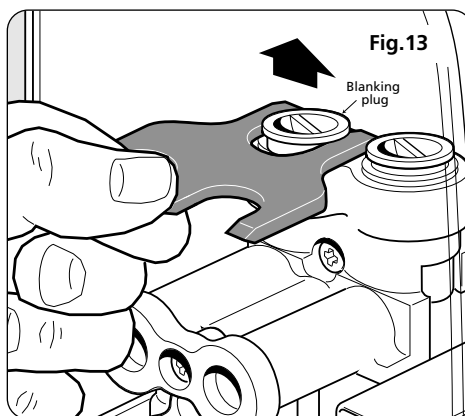
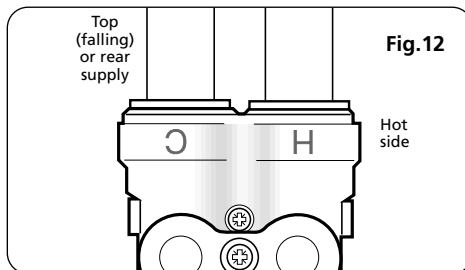
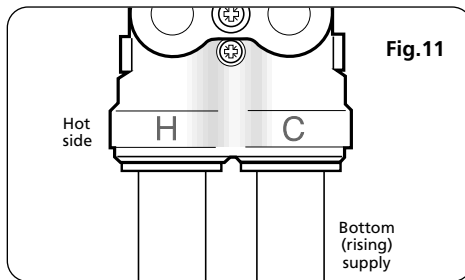

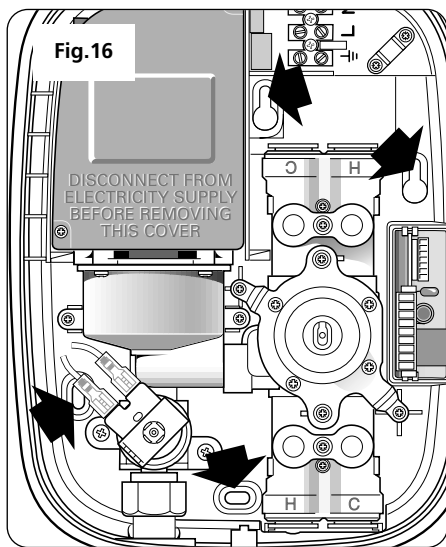
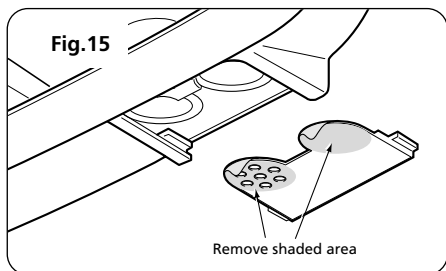
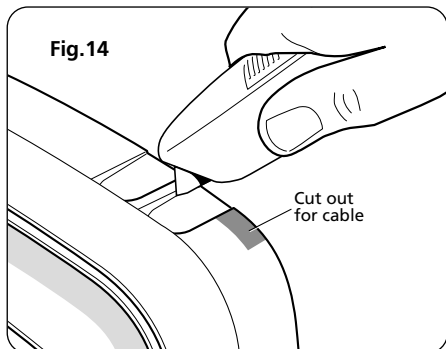

FITTING THE SHOWER TO THE WALL

Important: Prior to fitting the shower, ensure plumbing is flushed out, removing all debris, flux etc.

For top pipe entry or top cable entry, remove the relevant cut-outs by either breaking out or by using a knife or junior hack saw (fig.14).

If top entry for both pipe and cable is required, then additionally remove the shaded area (fig.14) by using a knife or junior hacksaw.

For bottom pipe entry, remove the cut-out and break off the two circular parts (fig.15).

Replace the cut-out.

For rear pipe entry only, the supplied elbows must be used with the necessary portion of backplate cut away as shown in fig.9.

It will be necessary if rear cable entry is required, for conduit or other routing of the electrical cable to be completed before fixing the shower to the wall.

Offer the backplate unit up to the completed pipework and manoeuvre so that the end of the pipes enter fully into the inlet fittings.

Mark positions for wall fixing holes using backplate as template (fig.16). Note that four fixing holes are provided but using only two should be adequate for most site conditions.

Using the pipe removal tool supplied, push back and hold the collects from the pipework (fig.17) in order to disengage pipework from the inlet elbows.

Remove unit from the wall.

Drill and plug the fixing holes to suit the type of wall and fixing screws supplied. **NOTE:** If fitting rising supplies to the unit, ensure debris does not enter the pipes when drilling the wall.

Offer the back plate unit up to the completed pipework and manoeuvre so that the end of the pipes enter fully into the inlet fittings.

Check the backplate is square and the fixing holes are aligned (fig.16).

Secure to the wall with fixing screws supplied.

ELECTRICAL CONNECTIONS

WARNING: THIS UNIT MUST BE EARTHED. ISOLATE THE ELECTRICAL SUPPLY BEFORE PROCEEDING.

The supply cable must conform to relevant tables in current IEE regulations. In most cases 1mm² twin and earth will be adequate.

The electrical rating of the shower is on the rating label within the unit.

SWITCH OFF THE ELECTRICITY SUPPLY.

Cable entry points are shown in fig.1. Conduit entry can only be from the rear.

Route the cable into the shower, taking care to avoid the area of the wall fixings and connect to the terminal block (fig.18) as follows:-

Live cable to terminal marked L

Neutral cable to terminal marked N

Earth cable to terminal marked E \perp

Important: Fully tighten the terminal block screws and ensure that no cable insulation is trapped under the screws. NOTE: The supply cable earth conductor must be sleeved and the cable clamp (fig.18) used to secure the cable.

The earth continuity conductor of the electrical installation must be effectively connected electrically to all exposed metal parts of other appliances and services in the room in which the shower is to be installed, to conform to current IEE regulations.

NOTE: Fuses do not ensure user protection against electric shock. In the interest of electrical safety, all mains electric and pumped showers should be fitted with a 30mA residual current device (RCD). This may be part of the consumer unit or a separate unit.

DO NOT switch on the electricity supply until the water has been turned on to the unit and connections have been tested for leaks.

THE COVER MAY BE LEFT OFF INITIALLY ONLY FOR COMMISSIONING.

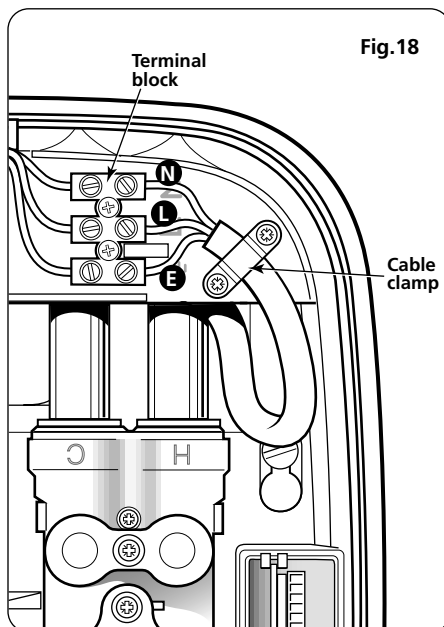
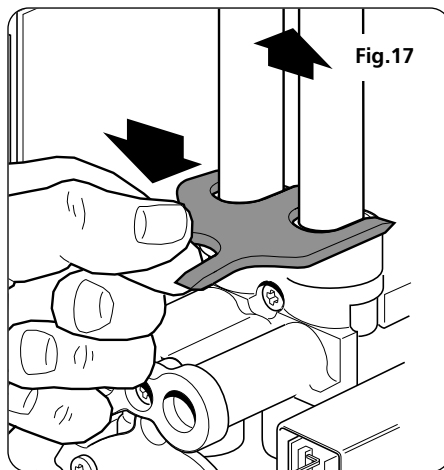

COMMISSIONING

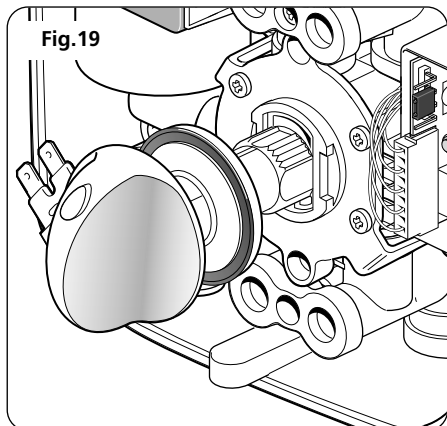

WARNING: Before normal operation of the shower, it is essential that the commissioning and setup procedure are correctly completed. Failure to do so could cause the pump to run dry without water and invalidate your guarantee.

The first operation of the shower is intended to flush out any remaining system debris and to ensure water is purged through the unit. This operation must be carried out with the flexible hose screwed to the shower outlet but *without* the sprayhead attached.

Ensure the outlet of the flexible hose is directed to waste.

Ensure the gate valves controlling the water supply to the unit are fully open.

(There is no need to fit cover at this stage but be aware of live parts when the electricity is switched on temporarily).

Fit the temperature control onto the adaptor (fig.19). This is a push fit and will only fit one way.

On the PCB, ensure the commissioning link is positioned on the middle two pins (fig.20).

Switch on electric supply at isolating switch. Water will begin to flow under gravity pressure.

*(Once the unit has been commissioned, disconnect the electricity supply **before** removing the commissioning link).*

WARNING: Be aware of live parts in the unit when the electricity is switched on. **DO NOT** tamper with any parts and **DO NOT** deviate from the following instructions.

In order to dispel air and to prime both supplies to the shower unit, turn the temperature control several times within its rotational limits. **ONCE RESISTANCE IS FELT, DO NOT FORCE THE CONTROL FURTHER.**

NOTE: The temperature control rotates less than one complete turn (fig.21) – from

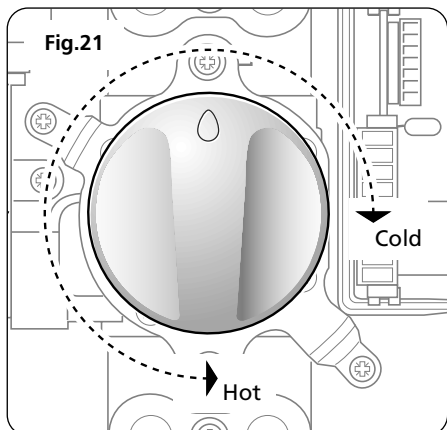
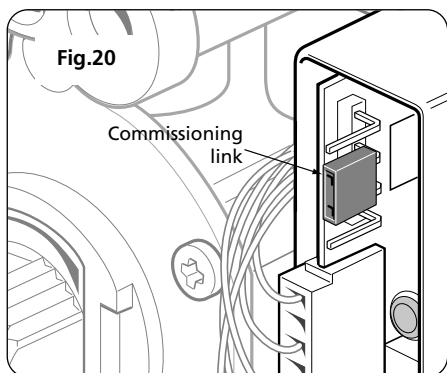

3 o' clock (cold) anti-clockwise to 6 o' clock position (hot) and visa versa. DO NOT force it beyond these limits.

To stop the water flow, switch off the electricity supply at the isolating switch.

Check for leaks in the pipework and remedy if necessary. If rear entry has been used then seal around pipes with mastic to prevent the possibility of water entering the wall cavity. DO NOT use plaster as this could cause difficulty if maintenance is required at a later date.

Setup procedure

ENSURE THE ELECTRICITY TO THE UNIT IS SWITCHED OFF.

Pull off the temperature control knob.

Remove the commissioning link from the PCB (fig.22) and store safely for future use.

Offer the cover to the unit. Attached to the flow control potentiometer inside the cover is a 4 wire lead. Fit the connector on the end of this lead to the 4 pins on the PCB (fig.23) – it can fit either way.

Replacing the cover

Fit the cover, ensuring the connector is fitted to the PCB and the wires are clear of the setting adaptor. Secure with the top and bottom fixing screws (fig.8).

Ensure the maximum temperature stop is still in position.

NOTE: If adjustment of the maximum temperature stop is required, refer to section '*Adjusting the maximum temperature stop*'.

Replace the temperature control knob by push fitting onto the adaptor shaft, noting that it will only fit one way.

Ensure the flow control is positioned at 'stop' (fig.24).

Switch the electricity supply back on at the isolating switch. Ensure both water supplies are still turned on.

Once the installation of the riser rail is complete, the shower is ready for normal operation.

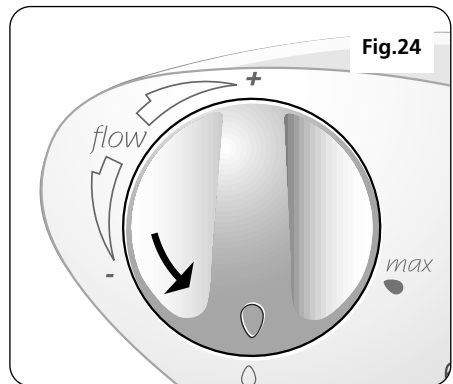
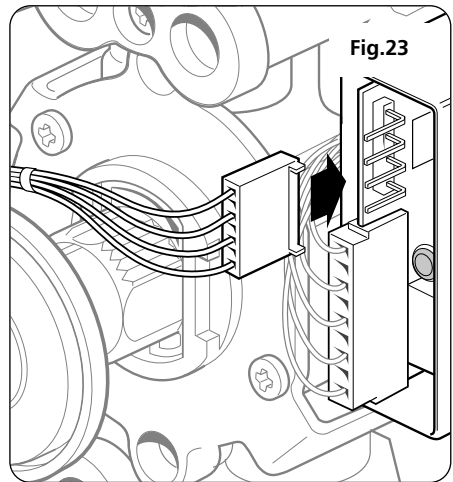
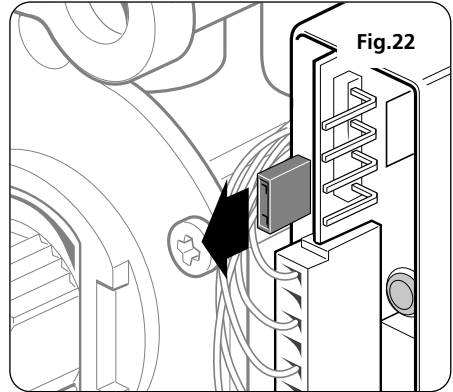

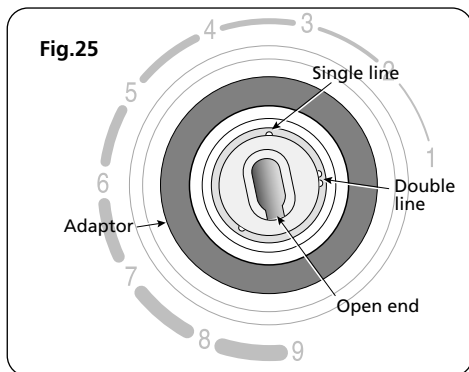

TEMPERATURE CONTROL SPINDLE SETTING

Occasionally the knob adaptor may become detached when the temperature control knobs and cover are removed from the unit. To replace the adaptor and to ensure it is located in the correct alignment, please refer to the following:

AS2000 manual valve

With the adaptor removed, use your fingers to turn the valve spindle fully anti-clockwise. Re-fit the adaptor onto the spindle aligning the single line on the adaptor to the 12 o'clock position (the 'double line' will be at the 3 o'clock position). The temperature control location 'open end' must relate to '9' on the temperature scale when the cover is fitted (fig.25).

NOTE: Incorrect positioning will result in excessive cold bleed.

AS2000 thermostatic valve

With the adaptor removed, use your fingers to adjust the brass splined spindle until the black line on the spindle lines up with the groove in the top of the valve spindle housing (fig.26).

Re-fit the adaptor onto the brass splined spindle aligning the single line on the adaptor with both the black spindle mark and the housing groove (the 'double line' will be at the 8 o'clock position). The temperature control location 'open end' must relate to '5' on the temperature scale when the cover is fitted (fig.27).

NOTE: Incorrect positioning will result in excessive cold bleed.

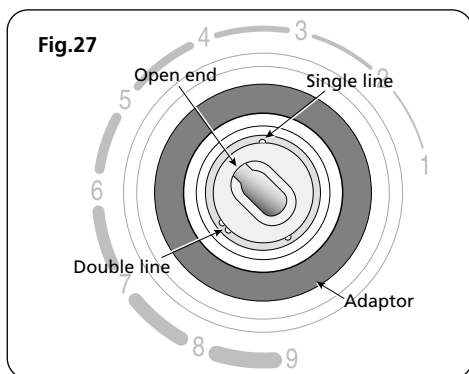
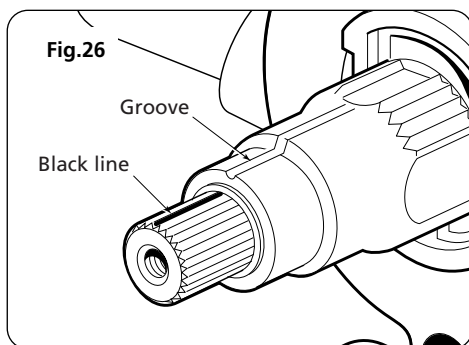

FITTING THE RISER RAIL

WARNING: Check there are no hidden cables or pipes before drilling holes for wall plugs. Use great care when using power tools near water. The use of a residual current device (RCD) is recommended.

Decide the position for the rail on the wall within the shower area. Proceed as follows:

A Offer one of the two brackets to the wall for the lower position only. Note there are three holes in the brackets but two screws will usually be sufficient. However, the centre hole must be used so mark this and either of the other two. Drill and plug the wall. Replace the bracket to the wall and secure to the wall with the screws supplied (fig.28). Locate the rail onto this lower bracket ensuring the rail engages fully on the bracket. Ensure the indent in the riser rail engages into the cut-out on the bracket end (fig.29).

B Locate the second bracket on top of the rail. Again mark the centre hole plus one of the other two holes. Ensure the rail is vertical. Remove the bracket and rail. Drill and plug the wall.

C With the saddle, spacer and lever parts to hand, screw the saddle 2 or 3 turns into the lever (fig.30). Place the saddle and lever into the slider/holder assembly (fig.31) so that the holes align, then slide onto the rail (fig.32). Tighten to the rail by turning the lever. When tight, the lever should be facing forwards and not pointing to the wall. If not, slacken off and remove from the rail. Rotate the saddle and lever 180° within the slider/holder assembly then replace onto the rail and tighten. Ensure the tapered thin end of the spray head holder is in the uppermost position.

D Place the rail onto the installed lower bracket. Replace the upper bracket onto the

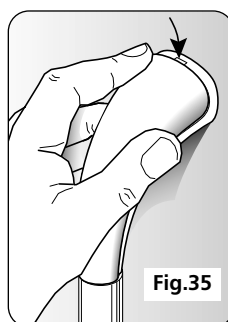
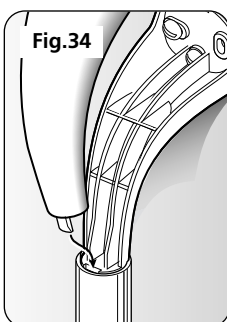
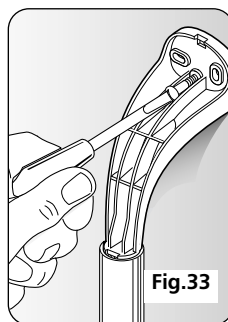
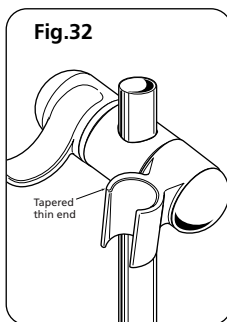
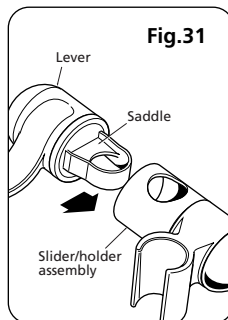
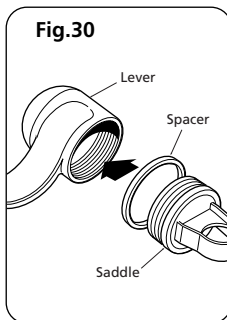
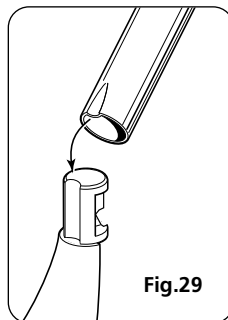
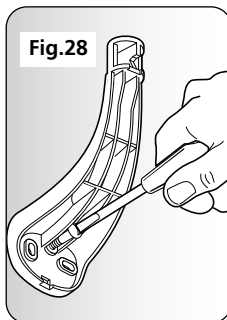

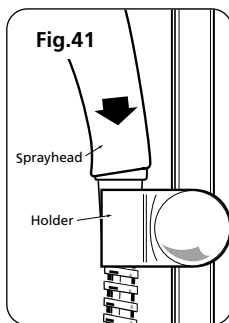
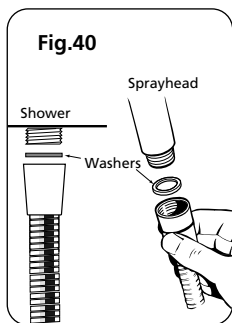
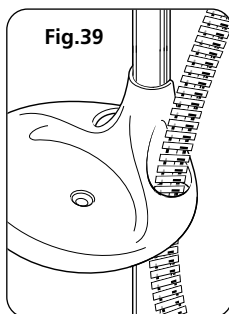
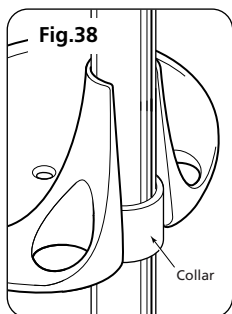
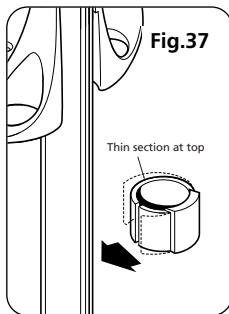
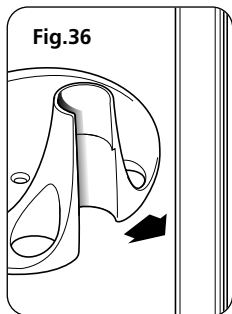

rail and secure the bracket to the wall with the screws supplied (fig.33).

E Place a trim cover onto each bracket ensuring the large protrusion at the narrow end of the trim cover, engages into the slot between the rail and bracket (fig.34) before pushing and clicking the other end into place (fig.35). Should the need arise, the trim covers can be removed by inserting a screwdriver into the slot and carefully levering off the trim.

F Snap the soap dish onto the rail (fig.36) below the holder assembly. Prise open the soap dish collar and fit onto the rail (fig.37) below the dish. Note the collar is slightly tapered and should be fitted 'thinner section' uppermost. Ensure it locates firmly in the soap dish (fig.38) so that it holds the dish at the required height on the rail.

FITTING THE HOSE AND SPRAYHEAD

Feed the flexible hose through the appropriate soap dish aperture (fig.39) in order that the dish acts as a retaining ring (Water Supply Byelaw 17).

Screw the flexible hose to the shower outlet and sprayhead (fig.40) ensuring the supplied washers are in place at both ends of the flexible hose.

Place the sprayhead into the holder (fig.41) and check that it fits correctly. **NOTE:** The holder is slightly tapered and the sprayhead and hose will only fit from one direction.

Important: It is the conical end of the hose which grips into the holder. The sprayhead will not fit in the holder without the hose attached.

OPERATING THE SHOWER

Ensure all plumbing and electrical supplies are connected and switched on.

To start the shower, rotate the flow control clockwise from the 'stop' position (fig.42). Adjust the control until the flow rate is satisfactory.

For maximum flow, turn the flow control fully clockwise to the 'max' position.

To adjust the temperature, rotate the control (fig.43). The temperature is numbered for ease of use. The temperature ranges from '1' – fully cold to '9' – fully hot.

Once the preferred temperature is reached, no further adjustment is required, providing the hot and cold water supplies remain constant.

To stop the shower, return the flow control to the 'stop' position by rotating anti-clockwise (fig.44). This stops the pump and water flow.

Unless the shower is to be used again immediately, the shower should also be switched off at the electricity isolating switch.

As a safety feature, the temperature control has a built-in stop to prevent you accidentally exceeding your highest desired temperature. If adjustment is required see section 'Adjusting the maximum temperature stop'.

To override this stop, depress the button (Fig.45) while the control is up against the stop and turn the control anti-clockwise to the higher settings (pressing the button before the stop will not operate the override mechanism even if the control is turned with the button depressed).

To return to the normal temperature range just turn the temperature control clockwise until it is past the maximum temperature stop. Ensure that the temperature control is

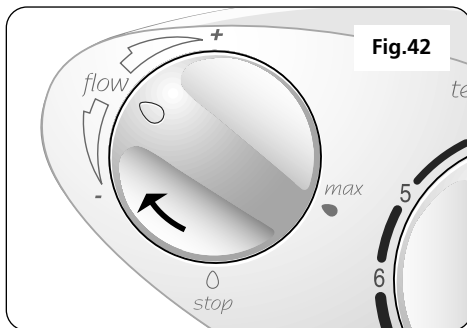

Fig.42

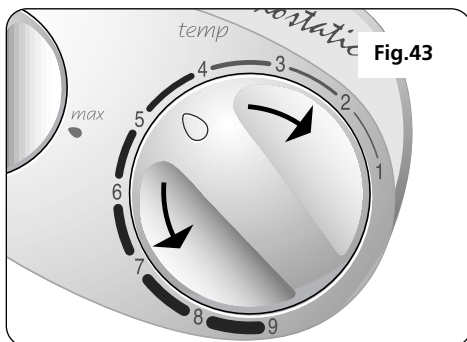

Fig.43

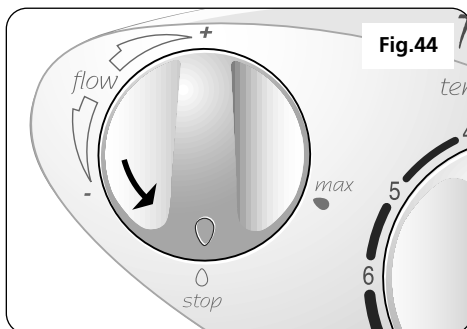

Fig.44

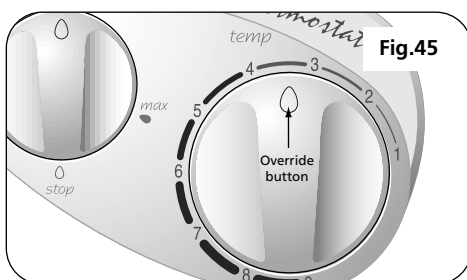
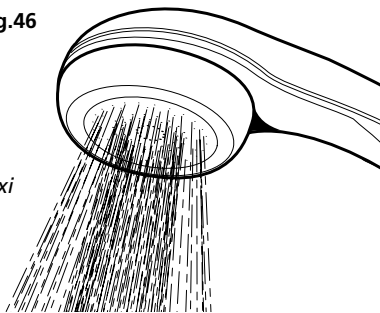

Fig.45

Fig.46

Maxi*Ultra**Needle**Jet*

in the normal temperature range when the shower is switched off. The stop comes in a factory set position based on 65°C stored hot water temperature.

CAUTION: It is recommended that persons who may have difficulty understanding or operating the shower controls should not be left unattended whilst showering. Special consideration should be given to young children and the less able bodied.

NOTE: As the flow control is adjusted it is quite normal for the sound of the pump to alter in pitch.

ADJUSTING THE SPRAYHEAD

Four sprayhead patterns are available (fig.46). Adjustment is by turning the bezel on the sprayhead in either direction until the desired pattern is obtained.

Maxi

A full spray perfect for a relaxing shower.

Ultra

A focused spray for a refreshing, satisfying shower.

Needle

A tingling, fine spray for a highly invigorating shower.

Jet

A concentrated spray for an exhilarating shower.

ADJUSTING THE MAXIMUM TEMPERATURE STOP

As a safety feature the shower has a built-in maximum temperature stop to prevent you accidentally exceeding your highest desired temperature. This is set in the factory to provide a maximum temperature based on the hot and cold water supplies being 65°C and 15°C respectively.

Procedure:

Pull off the temperature control (fig.47).

Carefully pull off the maximum temperature stop mechanism.

To increase the temperature stop setting, reposition the mechanism anti-clockwise within the arc of the grooves (fig.48).

To decrease the temperature stop setting, reposition the mechanism clockwise within the arc of the grooves (fig.48).

Replace the temperature control by push fitting onto the adaptor shaft, noting that it will only fit one way.

Important: Only adjust the maximum temperature stop when the hot water is at its usual storage temperature.

WARNING: The AS2000 manual shower does not contain a thermostatic valve – it will not shut off in the event of failure of either the hot or cold water supplies.

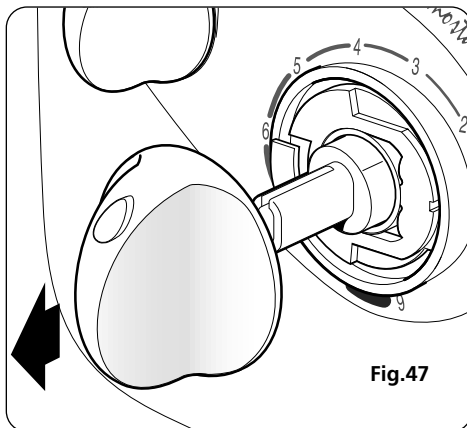

Fig.47

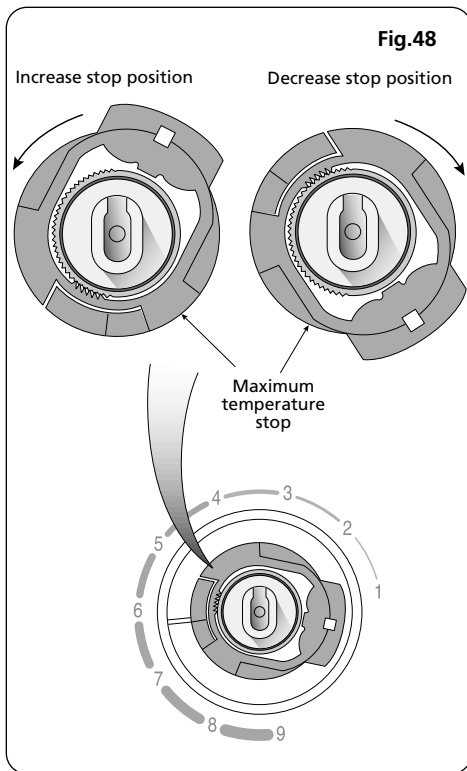

Fig.48

CLEANING

It is recommended that the shower, riser rail, hose etc. be cleaned using a soft cloth and that the use of abrasive or solvent cleaning fluids be avoided, especially on all gold effect finishes. It is advised before cleaning, that the isolation switch be turned off, thus avoiding accidental switching on of the shower.

IT IS MOST IMPORTANT TO KEEP THE SPRAYHEAD CLEAN IN ORDER TO MAINTAIN THE PERFORMANCE OF THE SHOWER.

The hardness of the water will determine the frequency of cleaning.

Sprayplate and cartridge removal

There is no need to remove the sprayhead from the hose.

Using the removal tool supplied (fig.49), locate the three raised 'bosses' into the three recesses in the sprayplate. Hold in firmly and twist anti-clockwise (fig.50). This movement may turn the cartridge assembly as well until it reaches a 'stop'. Hold the cartridge firmly and continue to twist anti-clockwise. Having loosened the sprayplate sufficiently, it can be unscrewed and removed completely (fig.51). To remove the cartridge, hold firmly and turn anti-clockwise until it unscrews from the sprayhead (fig.52).

Clean the sprayplate and cartridge with a suitable brush or preferably leave them to soak overnight in a mild proprietary descaler. Ensure all traces of scale are removed and thoroughly rinse in clean water afterwards.

Before replacing the sprayplate and cartridge, it is advisable to direct the hose and sprayhead to waste, and start the shower to flush out any loose scale deposits.

Stop after approximately 30 seconds.

Refit the sprayplate and cartridge by screwing both in clockwise. Use the tool to screw in the sprayplate tight.

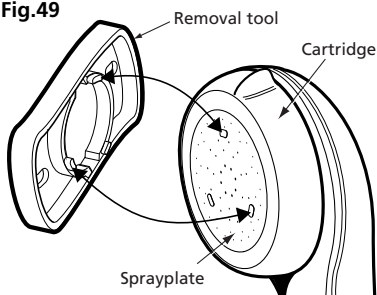
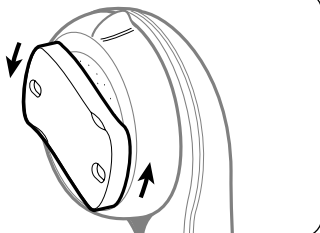
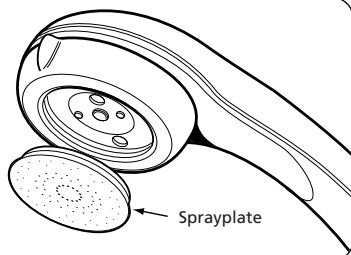
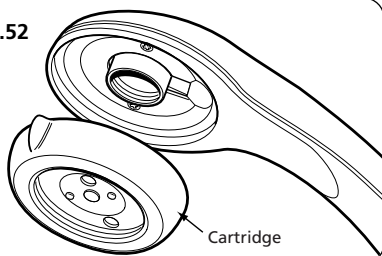
Fig.49**Fig.50****Fig.51****Fig.52****WARNING**

Do not use 'powerful' abrasive or solvent cleaning fluids when cleaning the shower as they may damage the plastic fittings

CLEANING THE FILTERS

NOTE: Isolate the electricity and both hot and cold water supplies to the unit before proceeding further.

Remove the shower unit cover by first pulling off the temperature control and then remove the two fixing screws – top and bottom. NOTE: Be aware of the lead connected to the PCB unit. Carefully pull off the lead from the PCB. DO NOT let the cover dangle by the lead.

Remove the single retaining screw from either the upper or lower filter cover (fig.53), depending upon whether top/rear entry or bottom entry is used.

Pull off the filter cover.

Carefully hook out the filters together with 'O' rings. Thoroughly clean and replace ensuring the 'O' rings are in position.

Refit the filter cover and secure with the screw.

Offer the cover to the unit and replace the four wire lead to the PCB. Secure the cover with the top and bottom fixing screws. Replace the temperature control.

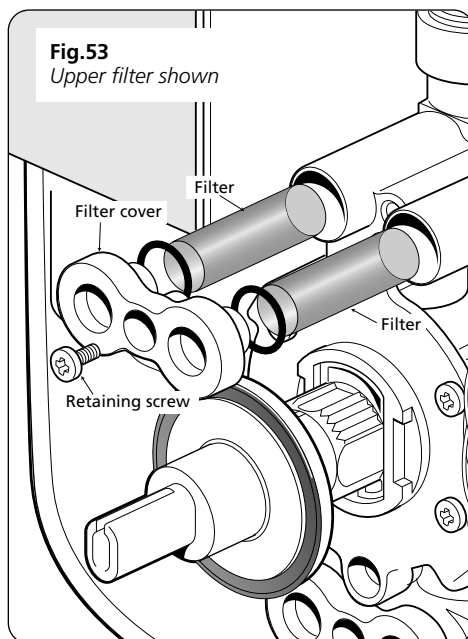

SPARE PARTS

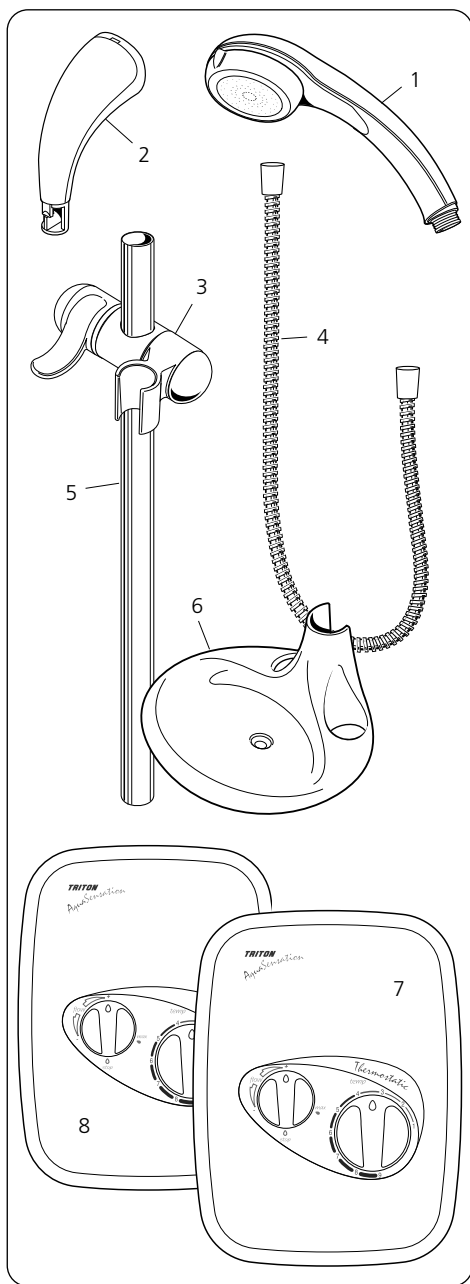

Ref.	Description	Part No.	
1	4 mode sprayhead		
	white/chrome	22008230	
	gold effect	22008240	
	white	22008250	
2	Brackets – pair	white	83306160
		chrome	83306170
		gold	83306180
3	Sprayhead holder	white	83306190
		chrome	83306200
		gold	83306210
4	Flexible hose	chrome	22003970
		white	22003960
		gold	22003980
5	Riser rail – 430mm	anodised chrome	7042409
		white	7042411
		gold	7042410
6	Soap dish		
	white	22008960	
7	Cover - thermostatic	83305350	
	(c/w knobs & potentiometer)		
8	Cover - manual	83305250	
	(c/w knobs & potentiometer)		

SPARE PARTS

Ref.	Description	Part No.
9	Temperature control (c/w override button)	83305260
10	Maximum temperature stop	7052186
11	Pump & motor assy	83305290
12	Temperature valve (thermostatic)	83305270
-	Temperature valve (manual)	83305280
13	Pipe inlet elbow (c/w filters & check valves)	83305320
14	PCB unit	7072177
15	Pipe removing tool	7052144
16	Pipe trim	7052146
17	Terminal block	22001320
18	Solenoid assembly	82300430
19	Cable clamp	7052145
20	Motor cover	83305300
21	Filter (pair)	83305330
-	Wire kit	83305340

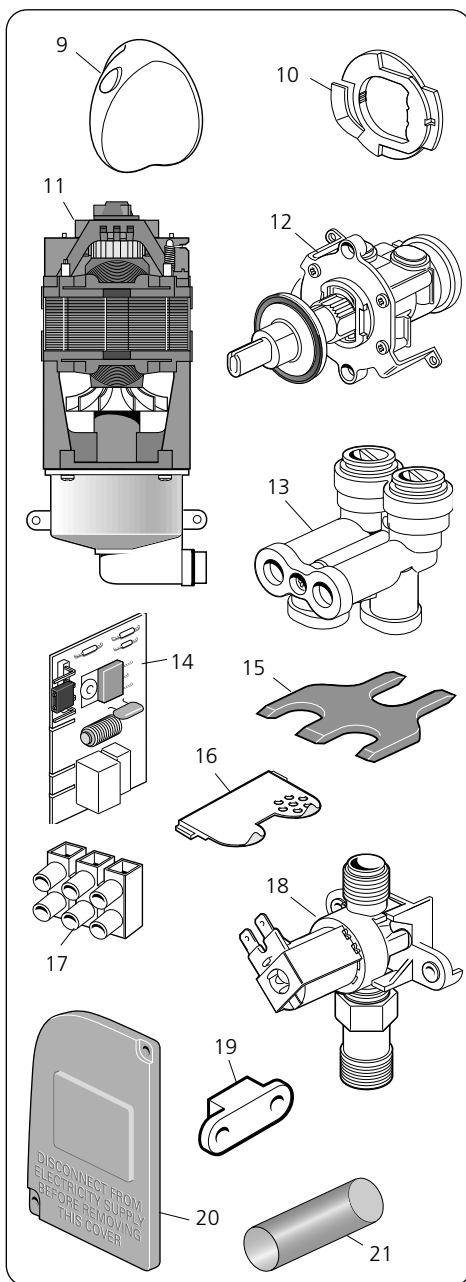

FAULT FINDING

<i>Symptom</i>	<i>Cause</i>	<i>Action/Cure</i>
1 Water too hot.	1.1 Not enough cold water flowing through shower.	1.1.1 Turn the temperature control clockwise.
	1.2 Increase in the ambient cold water temperature.	1.2.1 Turn the temperature control clockwise.
	1.3 Cold inlet filter blocked or check valve sticking.	1.3.1 Remove filter and clean. If problem is with check valve, contact Triton Customer Service.
	1.4 Cold water supply blocked or cut off.	1.4.1 Isolate shower and consult a competent plumber or contact Triton Customer Service.
2 Water too cold.	2.1 Not enough hot water flowing through shower.	2.1.1 Turn temperature control anti-clockwise.
	2.2 Decrease in ambient cold water temperature.	2.2.1 Turn temperature control anti-clockwise.
	2.3 No hot water in the storage cylinder.	2.3.1 Turn shower off and wait for hot water cylinder to reheat.
	2.4 Hot inlet filter blocked or check valve sticking.	2.4.1 Remove filter and clean. If problem is with check valve, contact Triton Customer Service.
	2.5 Hot water supply blocked or otherwise cut off.	2.5.1 Turn shower off. Consult a competent plumber or contact Triton Customer Service.
3 Pump does not operate.	3.1 Interrupted power supply.	3.1.1 Blown fuse. Check supply. Renew fuse. If it fails again consult a competent electrician. 3.1.2 Power cut. Check other appliances and if necessary, contact local Electricity Supply Co.
	3.2 Electrical malfunction.	3.2.1 Consult a competent electrician or contact Triton Customer Service.
	3.3 Motor overheated.	3.3.1 Thermal protection on motor has operated. Allow appliance to cool and reset itself. If it persists, contact Triton Customer Service.
4 Water does not flow or is reduced.	4.1 Water supplies cut off.	4.1.1 Check water elsewhere in house and if necessary contact the local Water Company.
	4.2 Shower blocked or air in the system.	4.2.1 Switch off shower and contact Triton Customer Service.
	4.3 Sprayhead blocked.	4.3.1 Clean sprayhead.
	4.4 Blocked filters.	4.4.1 Clean filters.
5 Cross flow of hot and cold water into system.	5.1 Dirt/debris in check valves.	5.1.1 Isolate water to unit. Remove check valves. Clean and replace.
6 Water dripping from shower head when turned off.	6.1 Debris in solenoid valve.	6.1.1 Call Triton Customer Service.
	6.2 Potentiometer faulty.	6.2.1 Call Triton Customer Service.

Any maintenance or repair to the shower must be carried out by a suitably competent person.



*A **MORGROS** Company*

TRITON STANDARD GUARANTEE

Triton Plc guarantee this product against all mechanical and electrical defects arising from faulty workmanship or materials for a period of one year for domestic use only, from the date of purchase, provided that it has been installed by a competent person in full accordance with the fitting instructions.

Any part found to be defective during this guarantee period we undertake to repair or replace at our option without charge so long as it has been properly maintained and operated in accordance with the operating instructions, and has not been subject to misuse or damage.

This product must not be taken apart, modified or repaired except by a person authorised by Triton Plc. This guarantee applies only to products installed within the United Kingdom and does not apply to products used commercially.

This guarantee does not affect your statutory rights.

What is not covered:

1 Breakdown due to: a) use other than domestic

use; b) wilful act or neglect; c) any malfunction resulting from the incorrect use or quality of electricity, gas or water or incorrect setting of controls; d) faulty installation.

2 Repair costs for damage caused by foreign objects or substances.

3 Call out charges where no fault has been found with the appliance.

4 The cost of repair or replacement of pressure relief devices, sprayheads, hoses, riser rails and/or wall brackets, isolating switches, electrical cable, fuses and/or circuit breakers or any other accessories installed at the same time as these do not form the mechanical and electrical components contained within the unit..

5 The cost of routine maintenance, adjustments, overhaul modifications or loss or damage arising therefrom, including the cost of repairing damage, breakdown, malfunction caused by corrosion, furring, pipe scaling, lime scale, system debris or frost.

Service Policy

In the event of a complaint occurring, the following procedure should be followed:

1 Telephone Customer Service on 02476 372222 (0345 626591 in Scotland and in Northern Ireland), having available the model number and power rating of the product, together with the date of purchase.

2 Triton Customer Service will be able to confirm whether the fault can be rectified by either the provision of a replacement part or a site visit from a qualified Triton service engineer.

3 If a service call is required it will be booked and the date of call confirmed. In order to expedite your request, please have your postcode available when booking a service call.

4 It is essential that you or an appointed representative (who must be a person of 18 years of age or more) is present during the service engineer's visit and receipt of purchase is shown.

5 A charge will be made in the event of an aborted service call by you but not by us, or where a call under the terms of guarantee has been booked and the failure is not product related (i.e. scaling and furring, incorrect water pressure, pressure relief device operation, electrical installation faults).

6 If the product is no longer covered by the guarantee, a charge will be made for the site visit and for any parts supplied.

7 Service charges are based on the account being settled when work is complete, the engineer will then request payment for the invoice. If this is not made to the service engineer or settled within 10 working days, a £10 administration charge will be added.

Replacement Parts Policy

Availability: It is the policy of Triton to maintain availability of parts for the current range of products for supply after the guarantee has expired. Stocks of spare parts will be maintained for the duration of the product's manufacture and for a period of five years thereafter.

In the event of a spare part not being available a substitute part will be supplied.

Payment: The following payment methods can be used to obtain spare parts:

1 By post, pre-payment of pro forma invoice by cheque or money order.

2 By telephone, quoting credit card (MasterCard or Visa) details.

3 By website order, www.tritonshowers.co.uk

Triton Plc, Shepperton Park, Caldwell Road,
Nuneaton, Warwickshire. CV11 4NR

Customer Service

 02476 372222

Scottish and Northern Ireland

Customer Service

 0345 626591

Trade Installer Hotline

 02476 325491

Fax: 02476 324564

E mail: reception@triton.plc.uk