



· T100si electric shower ·



Installation and Operating Instructions

INSTALLERS PLEASE NOTE THESE INSTRUCTIONS ARE TO BE LEFT WITH THE USER

CONTENTS	Page
Important safety information	1
Introduction	2
Advice to users	2
Key to main components	3
Electrical requirements	4 - 5
Water requirements	6
Siting of the shower	6 - 7
Fixing the shower to the wall	8
Plumbing connections	9
Electrical connections	10
Replacing the cover	11
Fitting the riser rail	12
Fitting the hose and sprayhead	13
Commissioning	14
Operating the shower	15 - 16
Operating functions	16 - 17
Adjusting the sprayhead	17
Cleaning	18
Cleaning the filter	19
Temperature / flow rate graph	19
Spare parts	20 - 21
Fault finding	22 - 23
Guarantee, service policy, etc.	rear cover

To ensure the product suitability for commercial and multiple installations, please contact Triton's specification advisory service prior to installation.

Telephone: (024) 7632 5491

Facsimile: (024) 7632 4564

E mail: technical@triton.plc.uk

PLEASE READ THIS IMPORTANT SAFETY INFORMATION

- ◆ Products manufactured by Triton are safe and without risk provided they are installed, used and maintained in good working order in accordance with our instructions and recommendations.
- ◆ DO NOT operate shower if frozen, or suspected of being frozen. It must thaw out before using.
- ◆ DO NOT operate the unit if the sprayhead or spray hose becomes damaged.
- ◆ DO NOT restrict flow out of the shower by placing sprayhead in direct contact with your body.
- ◆ DO NOT operate the shower if water ceases to flow during use or if water has entered inside the unit because of an incorrectly fitted cover.

1 GENERAL

- 1.1** Isolate the electrical and water supplies before removing the cover.
- 1.2** Read all of these instructions and retain them for later use.
- 1.3** DO NOT take risks with plumbing or electrical equipment.
- 1.4** Isolate electrical and water supplies BEFORE proceeding with the installation.
- 1.5** The unit must be mounted onto the finished wall surface (on top of the tiles). DO NOT tile up to unit after fixing to wall.
- 1.6** Contact Customer Service (see back page), if any of the following occur;
- a) If it is intended to operate the shower at pressures above the maximum or below the minimum stated.
 - b) If the unit shows a distinct change in performance.
 - c) If the shower is frozen.
- 1.7** If it is intended to operate the shower in areas of hard water (above 200 ppm temporary hardness), a scale inhibitor may have to be fitted. For advice on the Triton Scale Inhibitor, contact Triton Customer Service.
- 1.8** The sprayplate and cartridge must be cleaned regularly with descalent to remove scale and debris, otherwise restrictions to the flow on the outlet of the unit will result in higher temperatures and could also cause the Pressure Relief Device in unit to operate.
- 1.9** This product is not suitable for mounting into steam rooms or steam cubicles.

2 PLUMBING

- 2.1** The plumbing installation must comply with Water Regulations, Building Regulations or any particular regulations as specified by Local Water Company or Water Undertakers and should be in accordance with BS 6700.
- 2.2** The supply pipe must be flushed to clear debris before connecting to the shower unit.
- 2.3** DO NOT solder pipes or fittings within 300mm of the shower appliance, as heat transfer can damage components.

- 2.4** DO NOT fit any form of outlet flow control as the outlet acts as a vent for the heater can.
- 2.5** DO NOT use excessive force when making connections to the flexible hose or sprayhead, finger tightness is sufficient.
- 2.6** All plumbing connections MUST be completed BEFORE making the electrical connections.

3 ELECTRICAL

- 3.1** The installation must comply with BS 7671 'Requirements for electrical installations' (IEE wiring regulations) or any particular regulations as specified by the local Electrical Supply Company.
- 3.2** This appliance MUST be earthed.
- 3.3** In accordance with 'The Plugs and Sockets etc. (Safety) Regulations 1994', this appliance is intended to be permanently connected to the fixed wiring of the electrical mains system.
- 3.4** Ensure all electrical connections are tight to prevent overheating.
- 3.5** Fuses do not give personal protection against electric shock.
- 3.6** *To enhance electrical safety* a 30mA residual current device (RCD) should be installed in all UK electric and pumped shower circuits. This may be part of the consumer unit or a separate unit.
- 3.7** Switch off immediately at isolating switch if water ceases to flow during use.
- 3.8** Other electrical equipment i.e. extractor fans, pumps must not be connected to the circuits within the unit.
- 3.9** Switch off at isolating switch when not in use. This is a safety procedure recommended with all electrical appliances.
- 3.10** As with all electrical appliances it is recommended to have the shower and installation checked at least every two years by a competent electrician to ensure there is no deterioration due to age and usage.

INTRODUCTION

This book contains all the necessary fitting and operating instructions for your Triton T100si electric shower. Please read them carefully.

The shower installation must be carried out by a suitably qualified person and in the sequence of this instruction book.

Care taken during the installation will ensure a long, trouble-free life from your shower.

SPECIFICATIONS

Electrical

Nominal power rating at 240V	Nominal power rating at 230V
8.5kW – (40A MCB rating)	7.8kW – (40A MCB rating)
9.5kW – (40A MCB rating)	8.7kW – (40A MCB rating)

Water

Inlet connection – 15mm diameter.

Outlet connection – 1/2" BSP male thread.

Entry Points

Water – bottom or back.

Cable – top or back.

Materials

Backplate, cover, controls, sprayhead – ABS.

Sprayplate – Acetal.

Elements – Minerally insulated corrosion resistant metal sheathing.

Dimensions

Height - 338mm

Width - 208mm

Depth - 95mm

Standards and Approvals

Splashproof rating IPX4.

Complies with the requirements of current British and European safety standards for household and similar electrical appliances.

Complies with requirements of the British Electrotechnical Approvals Board (BEAB).

Meets with Compliance with European Community Directives (CE).

Due to continuous improvement and updating, specification may be altered without prior notice.

Replacement parts can be ordered from Customer Service. See 'spare parts' for details and part numbers.

ADVICE TO USERS

The following points will help you understand how the shower operates:

A The electric heating elements operate at a constant rate at your chosen power setting. It is the flow rate of the water passing through the heater can which determines the water temperature at any given setting. (The slower the flow the hotter the water becomes, and the faster the flow, the cooler the water).

B During Winter the ambient mains water supply will be cooler than in Summer, so to maintain your same showering temperature, you will have to decrease the water flow. The number displayed at the temperature control will therefore vary throughout the year as you adjust the position of the temperature control to maintain your desired showering temperature.

C The stabiliser valve minimises variations in shower temperature during mains water pressure changes. If changes in shower temperature are experienced during normal use, it will most likely be caused by the water pressure falling near to or below the minimum level. The drop in pressure may be due to water being drawn off at other points in the house whilst the shower is in use. If pressure drops appreciably below the minimum, the heating elements will automatically cut out.

If ever the water becomes too hot, and you cannot obtain cooler water, first check that the sprayplate in the sprayhead has not become blocked.

DO NOT place items such as soap or shampoo bottles on top of the unit. Liquid could seep through the joint between the cover and backplate, and possibly damage the sealing rubber.

Important: When first installed the unit will be empty. It is essential the unit should contain water *before* the elements are switched on. As this unit has electronic control, it is *vital* that the commissioning procedure is followed. Failure to carry out this operation will result in damage to the unit and will invalidate the guarantee.

KEY TO MAIN COMPONENTS

inside unit (fig.1)

- 1** Top cable entry
- 2** Bottom pipe entry
- 3** Rear pipe entry area
- 4** Rear cable entry area
- 5** Wall screw fixing
- 6** Terminal block
- 7** Power PCB
- 8** Stabilising valve
- 9** Solenoid valve
- 10** Guide pockets
- 11** Can and element assembly
- 12** Thermal cut-out (main)
- 13** Earth connection
- 14** Outlet temperature limiter

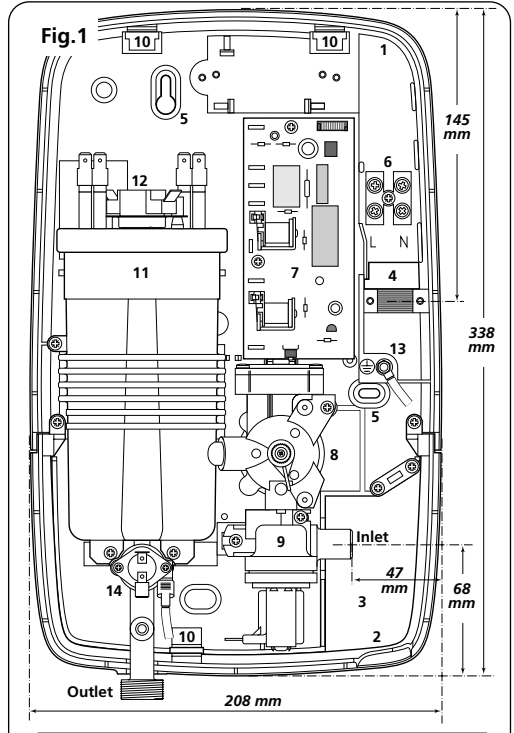

inside cover (fig.2)

- 16** Cover tags
- 17** Control PCB

Pack contents

- Shower unit
- Four position sprayhead
- Riser rail kit and fittings
- Soap dish
- Flexible hose
- Screw fixing kit
- Instructions, guarantee, etc.

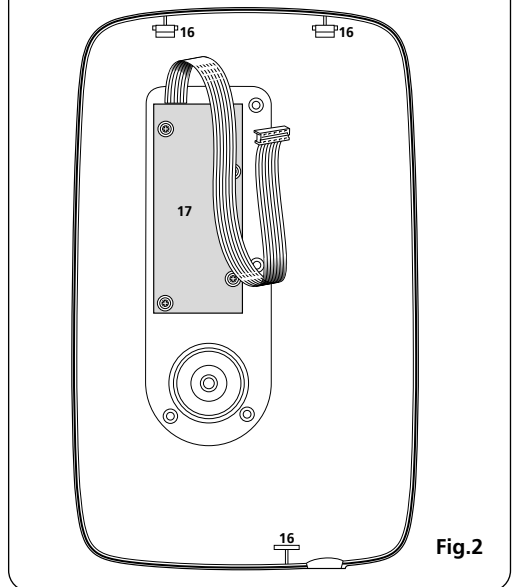

ELECTRICAL REQUIREMENTS

WARNING
THIS APPLIANCE MUST BE EARTHED

The installation, supply cable and circuit protection must conform with IEE wiring regulations and be sufficient for the amperage required.

The following notes are for guidance only:

1 The shower must only be connected to a 230-240V ac supply. If you are installing a shower with a kilowatt rating above 9kW, it is advisable to contact the local electricity supply company.

1.1 The electrical rating of the shower is shown on the rating label (fig.3) within the unit.



2 Before making any sort of electrical connection within the installation, ensure that no terminal is live. If in any doubt, switch off the whole installation at the consumer unit.

3 The shower must be connected to its own independent electrical circuit. IT MUST NOT be connected to a ring main, spur, socket outlet, lighting circuit or cooker circuit.

3.1 The electrical supply must be adequate for the loading of the unit and existing circuits.

4 Check your consumer unit (main fuse box) has a main switch rating of 80A or above and that it has a spare fuse way which will take the fuse or mcb necessary for the shower (fig.4).

4.1 If your consumer unit has a rating below 80A or if there is no spare fuse way, then the installation will not be straight forward and may require a new consumer unit serving the house or just the shower.

4.2 You will need to contact the local electricity company. They will check the circuit and carry out what is necessary. They will also check the main bonding.

5 The earth continuity conductor of the electrical installation must be effectively connected electrically to all exposed metal parts of other appliances and services in the room in which the shower is to be installed, to conform to current IEE regulations.

Fig.4 schematic of installation circuit

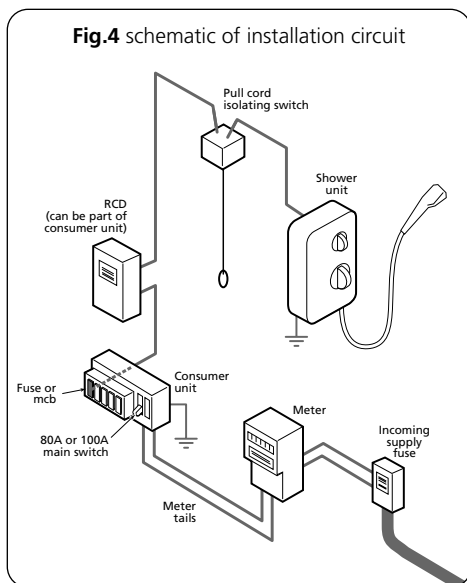

Table A

unit rating	CIRCUIT PROTECTION	
	mcb	cartridge fuse
7.0kW	30/32A	30A
7.5kW	32A	35A
8.0kW	40A	35A
8.5kW	40A	45A
9.0kW	40A	45A
9.5kW	40/45A	45A
10.5kW	45A	45A

ELECTRICAL REQUIREMENTS

5.1 All exposed metallic parts in the bathroom must be bonded together using a cable of at least 4mm² cross sectional area. These parts include metal baths, radiators, water pipes, taps and waste fittings.

6 For close circuit protection DO NOT use a rewirable fuse. Instead use a suitably rated miniature circuit breaker (MCB) or cartridge fuse (see table A).

6.1 In the interest of electrical safety a 30mA residual current device (RCD) should be installed in all UK electric and pumped shower circuits. This may be part of the consumer unit or a separate unit.

7 A 45 amp double pole isolating switch with a minimum contact gap of 3mm in both poles must be incorporated in the circuit.

7.1 It must have a mechanical indicator showing when the switch is in the OFF position, and the wiring must be connected to the switch without the use of a plug or socket outlet.

7.2 The switch must be accessible and clearly identifiable, but out of reach of a person using a fixed bath or shower, except for the cord of a

cord operated switch, and should be placed so that it is not possible to touch the switch body while standing in a bath or shower cubicle. It should be readily accessible to switch off after using the shower.

8 Where shower cubicles are located in any rooms other than bathrooms, all socket outlets in those rooms must be protected by a 30mA RCD.

9 The current carrying capacity of the cable must be at least that of the shower circuit protection (see table B).

9.1 To obtain full advantage of the power provided by the shower, use the shortest cable route possible from the consumer unit to the shower.

9.2 It is also necessary to satisfy the disconnection time and thermal constraints which mean that for any given combination of current demand, voltage drop and cable size, there is a maximum permissible circuit length.

10 The shower circuit should be separated from other circuits by at least twice the diameter of the cable or conduit.

10.1 The current rating will be reduced if the cabling is bunched with others, surrounded by thermal loft or wall insulation or placed in areas where the ambient temperature is above 30°C. Under these conditions, de-rating factors apply and it is necessary to select a larger cable size.

10.2 In the majority of installations, the cable will unavoidably be placed in one or more of the above conditions. This being so, it is strongly recommended to use a minimum of 10mm cabling throughout the shower installation.

10.3 In any event, it is essential that individual site conditions are assessed by a competent electrician in order to determine correct cable size and permissible circuit length.

Table B

**Twin and earth PVC insulated cable
CURRENT CARRYING CAPACITY**

installed in an insulated wall	in conduit or trunking	clipped direct or buried in a non insulated wall
6mm ² 32A	6mm ² 38A	6mm ² 46A
10mm ² 43A	10mm ² 52A	10mm ² 63A
16mm ² 57A	16mm ² 69A	16mm ² 85A

Note: Cable selection is dependent on de-rating factors

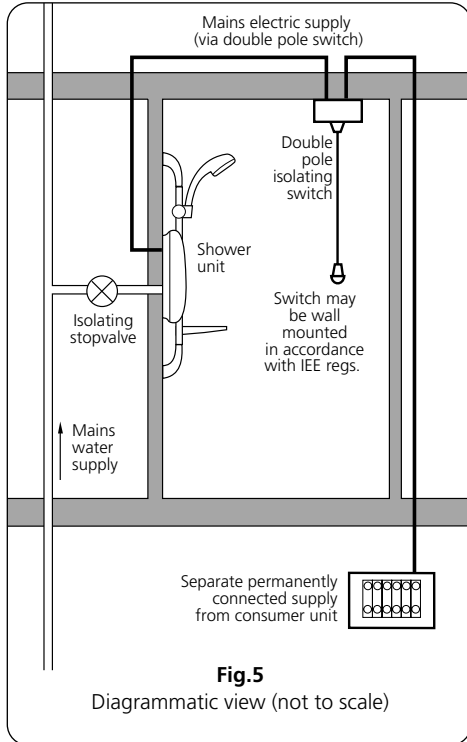

Fig.5

Diagrammatic view (not to scale)

WATER REQUIREMENTS

The installation must be in accordance with Water Regulations/Byelaws.

To ensure activation of the heating elements, the shower must be connected to a mains water supply with a minimum running pressure of 100 kPa (1.0 bar) at a minimum flow rate of eight litres per minute for the 8.5kW rated model and nine litres per minute for the 9.5kW rated model.

For both units the maximum static pressure must be 1,000 kPa (10 bar).

NOTE: If the stated flow rates are not available, it may not be possible to achieve optimum performance from the unit throughout the year.

During periods of high ambient temperatures it may be necessary to select a low power setting to achieve your preferred shower temperature.

The water supply can be taken from a cold water storage cistern *provided* there is a minimum head of ten metres above the sprayhead. It must be an independent supply to the shower only.

If it is intended to operate the shower at pressures above the maximum or below the minimum stated, contact Customer Service for advice.

Fig.5 shows a typical system layout.

Do not use jointing compounds on any pipe fittings for the installation.

SITING OF THE SHOWER

WARNING: The shower must not be positioned where it will be subjected to freezing conditions.

FOR EASE OF SERVICING, THE UNIT MUST ALWAYS BE MOUNTED ON THE SURFACE OF TILED WALLS. NEVER TILE UP TO THE UNIT.

Refer to **figure 6** for the correct siting of the shower. Position the unit where it will NOT be in direct contact with water from the sprayhead. Position the shower unit vertically.

Allow sufficient room between the ceiling and the shower to access the cover top screws.

NOTE: Water regulations require the sprayhead be 'constrained by a fixed or sliding attachment so that it can only discharge water at a point not less than 25mm above the spill-over level of the relevant bath, shower tray or other fixed

appliance'. The use of the supplied soap dish will in most cases meet this requirement, but if the sprayhead can be placed within a bath, basin or shower tray, then a double check valve, or similar, must be fitted in the supply pipework to prevent back-flow.

Pressure relief safety device

A pressure relief device (PRD) is designed into the shower unit which complies with European standards. The PRD provides a level of appliance protection should an excessive build up of pressure occur within the shower.

DO NOT operate the shower with a damaged or kinked shower hose, or a blocked sprayhead which can cause the PRD to operate.

When commissioning, the sprayhead must be removed from the flexible hose, while at the same time the temperature control must be at the minimum flow position. Failure to follow this procedure may also cause the PRD to operate.

Ensure the shower is positioned over a bath or shower tray because if the PRD operates, then water will eject from the bottom of the unit. Should this happen, turn off the electricity and water supplies to the shower at the isolating switch and stopvalve. Contact Customer Service for advice on replacing the PRD.

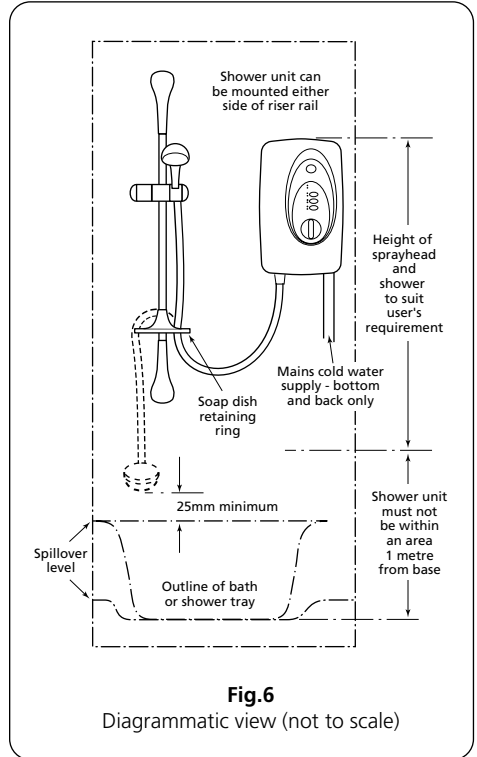

Important: The unit must be mounted on a flat surface which covers the full width and length of the backplate. It is important that the wall surface is flat otherwise difficulty may be encountered when fitting the cover and subsequent operation of the unit may be impaired.

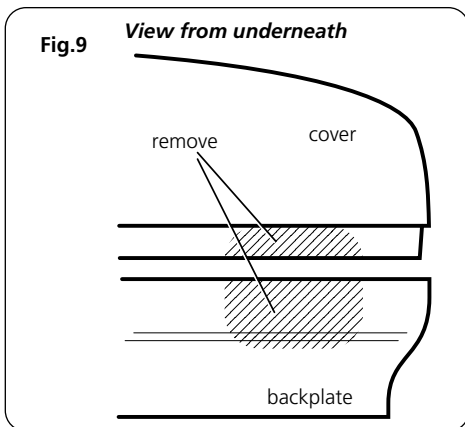
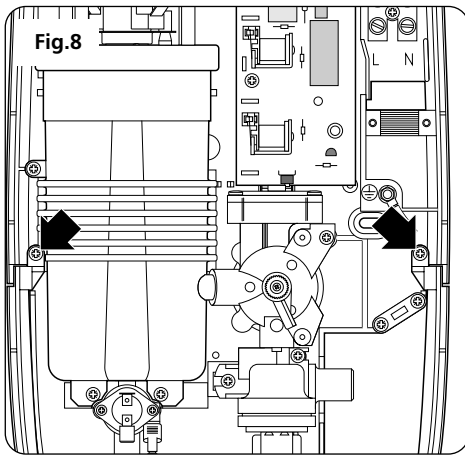
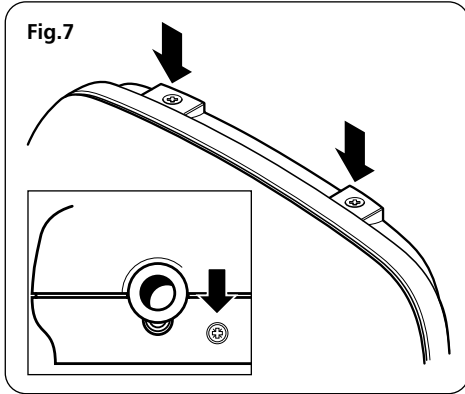

FITTING THE SHOWER TO THE WALL

NOTE: The control knob is an integral part of the cover – do not attempt to remove it.

Unscrew the two top and one bottom retaining screws (**fig.7**) and lift the cover from the backplate. To facilitate the pipe and cable connections, remove the two screws (**fig.8**) and take off the trimplate.

Entry positions for the mains water are from the bottom or from the rear. Cable entry is via the top or rear. NOTE: Deviations from the designated entry points will invalidate product approvals.

If bottom surface entry is required for the mains cold water, then the necessary aperture will need to be cut out in the trimplate and cover (**fig.9**).

If surface cable entry from the top is required then a small area will need to be cut out in the backplate (**fig.10**).

If installing a feed pipe from the rear or bottom, the centre of the inlet valve to the wall surface is 20mm (**fig.11**). NOTE: If entry is from the rear, the nut of the compression fitting will be partially behind the surface of the wall (**fig.11**). This area MUST be left clear when plastering over the pipework in order to make the nut accessible for future adjustments.

After choosing the site for the shower, use the backplate as a template and mark the two fixing holes (**fig.12**). Drill and plug to suit the fixing screws supplied.

(The wallplugs provided are suitable for most brick walls – use an appropriate masonry drill, but if the wall is plasterboard or a soft building block, you must use special wallplugs and an appropriate drill obtainable from most hardware stores).

Screw top fixing screw into position leaving the base of the screw head protruding 6mm (0.25in) out from the wall.

Hook the backplate over the top screw and fit the bottom fixing screw into position.

Do not fully tighten the screws at this stage, as the fixing holes are elongated to allow for out of square adjustment after the plumbing connections have been completed.

PLUMBING CONNECTIONS

Plumbing to precede wiring.

WARNING: The outlet of the shower acts as a vent and must NOT be connected to anything other than the hose and sprayhead supplied.

DO NOT use jointing compounds on any pipe fittings for the installation.

DO NOT use soldered fittings within the vicinity of the shower unit.

Compression fittings MUST be used to connect to the inlet of the shower. (Push-on fittings must NOT be used as full engagement cannot be guaranteed).

NOTE: An additional stopvalve (complying with Water Regulations) MUST be fitted in the mains water supply to the shower as an independent means of isolating the water supply should maintenance or servicing be necessary.

Important: Before completing the connection of the water supply to the inlet of the shower, flush out the pipework to remove all swarf and system debris. This can be achieved by connecting a hose to the pipework and turning on the mains water supply long enough to clear the debris to waste.

Procedure:

Turn off water supply either at the mains stopvalve or the isolating stopvalve. Connect the mains water supply to the inlet of the shower via 15mm copper, stainless steel or plastic pipe using a 15mm x 15mm elbow compression fitting. DO NOT use excessive force when making these connections.

Ensure the backplate is square on the wall and tighten the two retaining screws which hold it to the wall.

Turn on the mains water supply and check for leaks in the pipework connection to the shower.

NOTE: At this stage no water can flow through the unit.

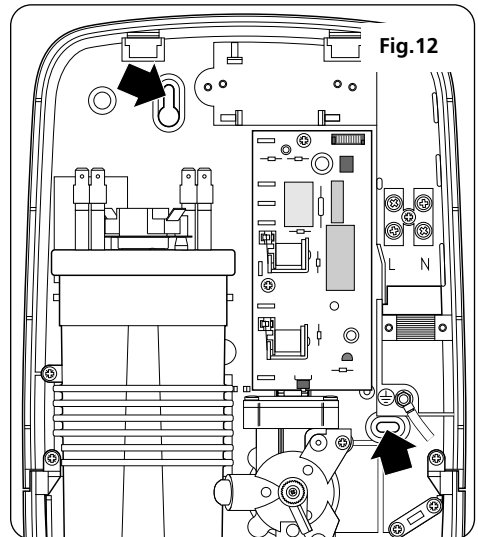
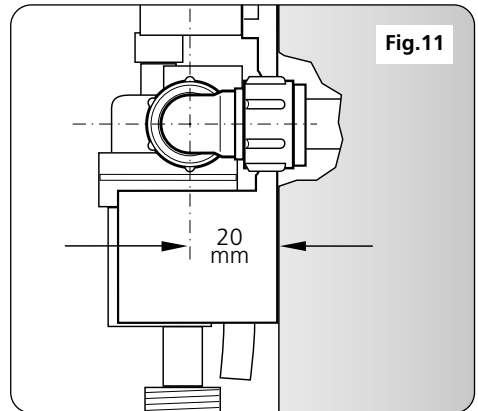
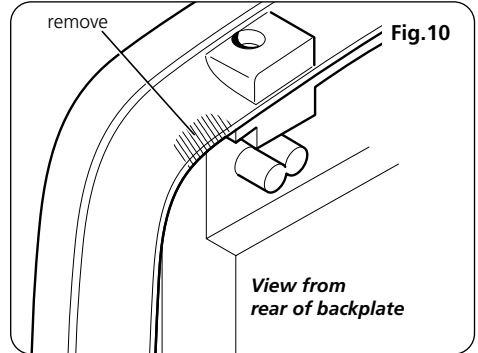

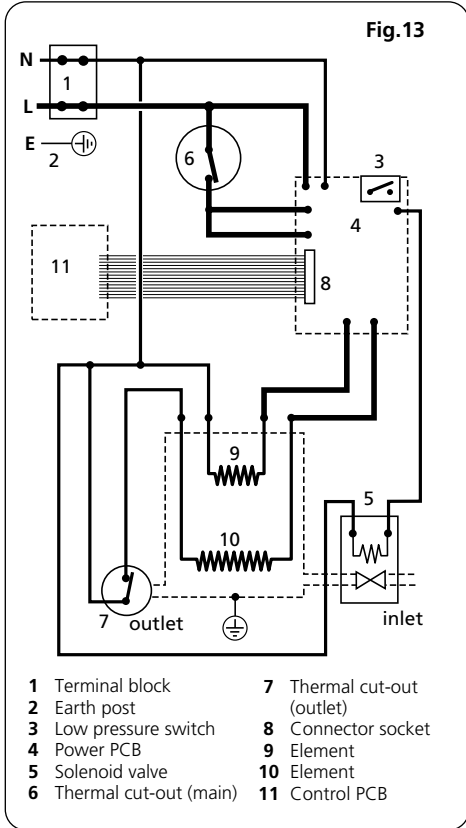

ELECTRICAL CONNECTIONS

SWITCH OFF THE ELECTRICITY SUPPLY.

Fig.13 shows a schematic wiring diagram.

The cable entry points are shown in figure 1. The cable can be surface clipped, hidden or via 20mm conduit.

NOTE: Conduit entry can only be from rear. Route the cable into the shower unit and connect to the terminal block (**fig.14**) as follows:-

Earth cable to terminal marked **E**

Neutral cable to terminal marked **N**

Live cable to terminal marked **L**

IMPORTANT: Fully tighten the terminal block screws and ensure that no cable insulation is trapped under the screws. Loose connections can result in cable overheating.

NOTE: The supply cable earth conductor must be sleeved. The outer sheath of the supply cable must be stripped back to the minimum.

The supply cable must be secured either by routing through conduit or in trunking or by embedding in the wall, in accordance with IEE regulations.

The use of connections within the unit, or other points in the shower circuit, to supply power to other equipment i.e. extractor fans, pumps etc. will invalidate the guarantee.

DO NOT switch on the electricity supply until the cover has been fitted.

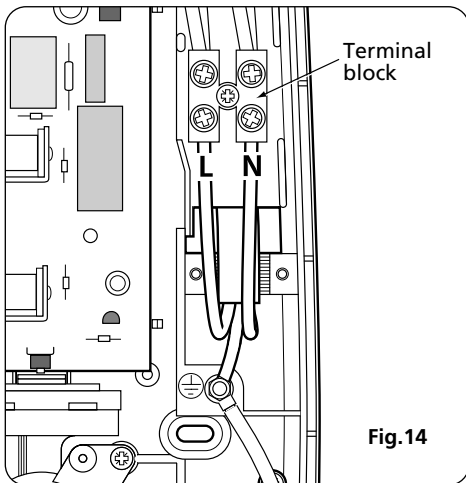

NOTE: The elements on UK models are to 240V specification and will give a lower kW rating if the voltage supply is below 240V.

REPLACING THE COVER

Refit the trimplate and secure with the two screws.

Turn the stabiliser valve spindle fully clockwise until the arm hits the 'stop' (**fig.15**). Turn the temperature control on the cover so that it points to '10' (**fig.16**).

Important: Before finally fitting the cover, the following steps must be taken:

- a Check plumbing connections for water tightness
- b Check terminal block screws are fully tightened.
- c Check the temperature control on the cover is pointing to '10'.
- d Ensure pipe and cable entering the unit do not prevent the cover locating correctly to the backplate.

Offer the cover to the unit. Attached to the control PCB inside the cover, is a ten way ribbon cable. The ribbon cable connector must be plugged into the socket located at the top right of the power PCB situated inside the unit (**fig.17**). The connector can only be correctly plugged in one way. The ribbon cable also has a coloured edge which is to the left when correctly fitted to the socket.

NOTE: The ribbon cable is pre-formed to fold flat when the cover is fitted.

Carefully locate the cover tags into the guide pockets on the backplate and ensure wires are not trapped. Guide into position so that the knob spindle locates correctly (minor adjustment may be necessary to align the knob and spindle). Should any difficulty arise, re-check the points above.

Whilst applying slight pressure to the front cover, secure in position with the three retaining screws.

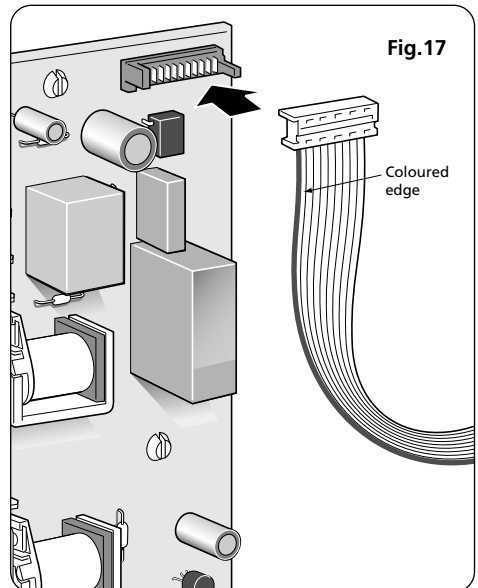
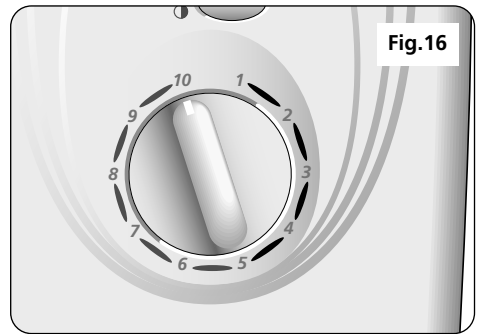
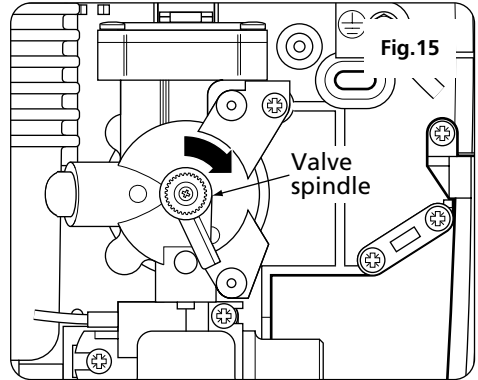

FITTING THE RISER RAIL

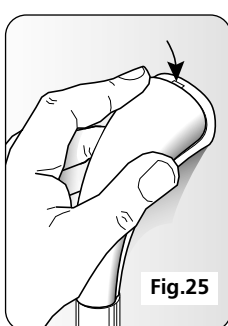
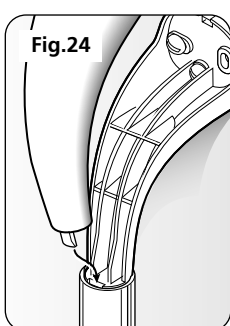
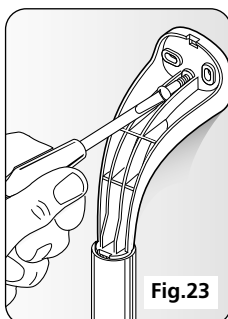
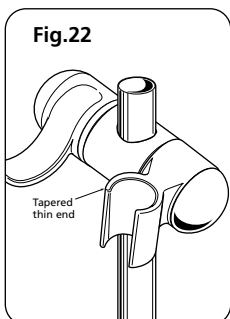
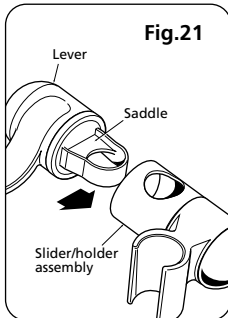
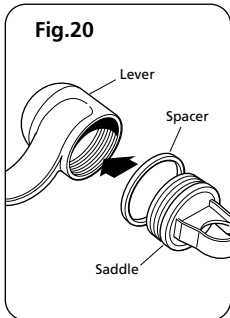
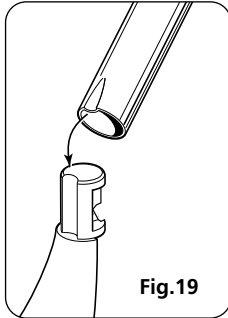
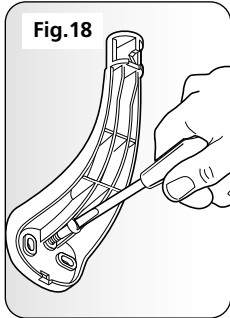

WARNING: Check there are no hidden cables or pipes before drilling holes for wall plugs. Use great care when using power tools near water. The use of a residual current device (RCD) is recommended.

Decide the position for the rail on the wall within the shower area. Proceed as follows:

A Offer one of the two brackets to the wall for the lower position only. Note there are three holes in the brackets but two screws will usually be sufficient. However, the centre hole must be used so mark this and either of the other two. Drill and plug the wall.

(The wallplugs provided are suitable for most brick walls – use an appropriate masonry drill, but if the wall is plasterboard or a soft building block, you must use special wallplugs and an appropriate drill obtainable from most hardware stores).

Replace the bracket to the wall and secure to the wall with the screws supplied (**fig.18**). Locate the rail onto this lower bracket ensuring the rail engages fully on the bracket. Ensure the indent in the riser rail engages into the cut-out on the bracket end (**fig.19**).

B Locate the second bracket on top of the rail. Again mark the centre hole plus one of the other two holes. Ensure the rail is vertical. Remove the bracket and rail. Drill and plug the wall.

C With the saddle, spacer and lever parts to hand, screw the saddle two or three turns into the lever (**fig.20**). Place the saddle and lever into the slider/holder assembly (**fig.21**) so that the holes align, then slide onto the rail (**fig.22**). Tighten to the rail by turning the lever. When tight, the lever should be facing forwards and not pointing to the wall. If not, slacken off and remove from the rail. Rotate the saddle and lever 180° within the slider/holder assembly then replace onto the rail and tighten.

Ensure the tapered thin end of the spray head holder is in the uppermost position.

D Place the rail onto the installed lower bracket. Replace the upper bracket onto the rail and secure the bracket to the wall with the screws supplied (**fig.23**).

E Place a trim cover onto each bracket ensuring the large protrusion at the narrow end of the trim cover, engages into the slot between the rail and

bracket (**fig.24**) before pushing and clicking the other end into place (**fig.25**).

F Snap the soap dish onto the rail (**fig.26**) below the holder assembly. Prise open the soap dish collar and fit onto the rail (**fig.27**) below the dish. Note the collar is slightly tapered and should be fitted 'thinner section' uppermost. Ensure it locates firmly in the soap dish (**fig.28**) so that it holds the dish at the required height on the rail.

FITTING THE HOSE AND SPRAYHEAD

Feed the flexible hose through the appropriate soap dish aperture (**fig.29**) in order that the dish acts as a retaining ring (in compliance with Water Regulations).

Screw the flexible hose to the shower outlet and sprayhead (**fig.30**) ensuring the supplied washers are in place at both ends of the flexible hose.

Place the sprayhead into the holder (**fig.31**) and check that it fits correctly. NOTE: The holder is slightly tapered and the sprayhead and hose will only fit from one direction. **Important:** It is the conical end of the hose which grips into the holder. The sprayhead will not fit in the holder without the hose attached.

However, at this stage disconnect the sprayhead and lay aside until the shower unit has been commissioned.

TIGHTENING THE SPRAYHEAD

In the unlikely event of the sprayhead dropping down in use because the holder is loose, this can be remedied by re-tightening the screw inside the holder unit. To gain access to this screw, one of the wall mounting brackets must be removed – the top one is preferable as the rail can be left in position on the lower bracket.

First remove the sprayhead and hose from the holder. Insert a small screw driver into the slot on the trim cover (**fig.32**), and carefully prise off the cover.

Unscrew the fixing screws holding the bracket and remove it from the wall and rail.

Holding the rail, unlock the lever and slide off the lever and holder assembly. Remove the lever and saddle from the slider/holder assembly. The screw inside the slider/holder is now accessible.

With an appropriate screw driver, tighten the screw (**fig.33**).

Re-assemble in the reverse order.

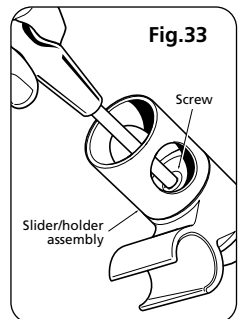
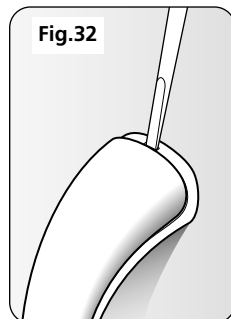
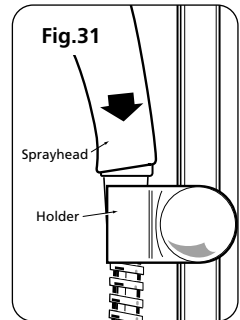
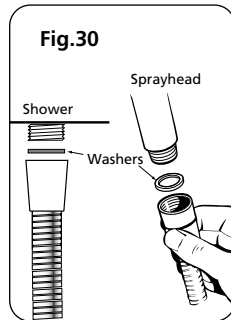
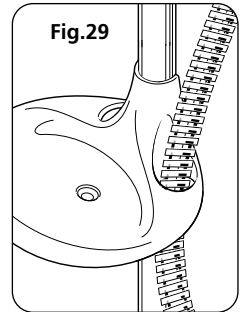
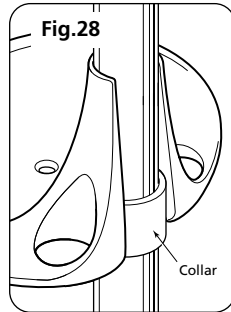
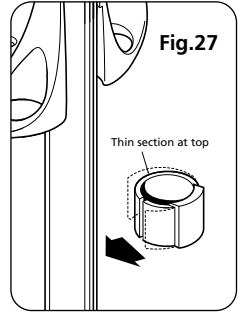
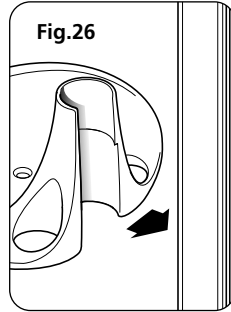

COMMISSIONING

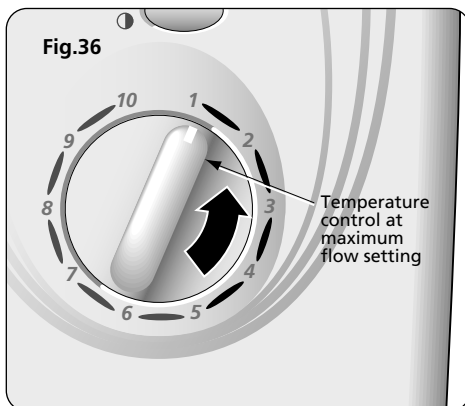
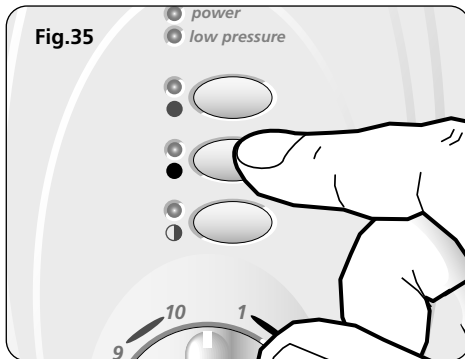
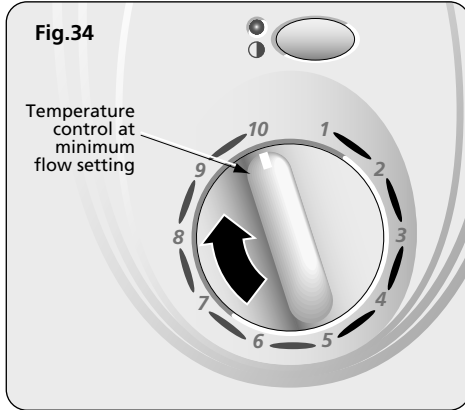

The first operation of the shower is intended to flush out any remaining unit debris, and to ensure the heater unit contains water before the elements are switched on. This operation must be carried out with the flexible hose screwed to the outlet but *without* the sprayhead attached. The 'COLD' position must be used. Ensure the outlet of the flexible hose is directed to waste.

Before turning on the electric and mains water supplies to the shower, ensure that the temperature control is rotated fully clockwise to '10' – the minimum flow position (**fig.34**).

NOTE: Failure to turn the control to '10' may cause the PRD to operate.

Turn on the water supply to the shower at the isolating stopvalve and then switch on the electricity supply to the shower at the isolating switch. The POWER indicator will light.

WARNING: Press the COLD button only (**fig.35**) and wait until water starts to flow from the flexible hose.

Slowly rotate the temperature control fully anti-clockwise to '1' – the maximum flow position (**fig.36**).

It will take approximately thirty seconds for a smooth flow of water to be obtained whilst air and any debris is being dispersed from the shower.

When a smooth flow of water is obtained, rotate the temperature control from '1' to '10' and back again several times to release any trapped air from within the unit.

Once the flushing out has been completed, stop the water flow by pressing the 'STOP' button.

Fit the sprayhead to the flexible hose and place in the sprayhead holder.

The shower is now ready for normal operation.

OPERATING THE SHOWER

Ensure the commissioning procedure has been carried out.

When the electricity supply to the shower is switched on at the isolating switch, the POWER indicator will light.

To start the shower

Water will flow by pressing any of the three buttons – COLD, ECONOMY or HIGH.

To stop the shower

Press the STOP button and the phased shutdown will commence. Water will cease to flow after approximately four seconds.

To use the control buttons

There are three control buttons – high, cold and economy (fig.37).

The upper button – red symbol ● is a high power setting which allows the highest flow achievable for your preferred temperature. This setting should normally be regarded as optimum shower performance throughout the year. Temperature adjustment at this setting is via the temperature control.

The centre button – blue symbol ● is for cold water only. Adjustment of the temperature control at this setting will only increase or decrease the force of the water from the sprayhead. *(It will not alter the water temperature).*

The lower button – red symbol ● is an economy setting for using less power when the ambient mains water temperature is high during hot months. Temperature adjustment at this setting is via the temperature control. NOTE: If the stated flow rate required for the unit cannot be met due to low water pressure, it will be necessary to operate the unit on this setting during the warmer months because of flow rate limitations entering the unit.

To adjust the shower temperature

The water temperature is altered by increasing or decreasing the flow rate of the water through the shower via the temperature control (fig.37).

After obtaining your preferred showering temperature, the number can be remembered and left as the normal setting and should only need to be altered to compensate for seasonal

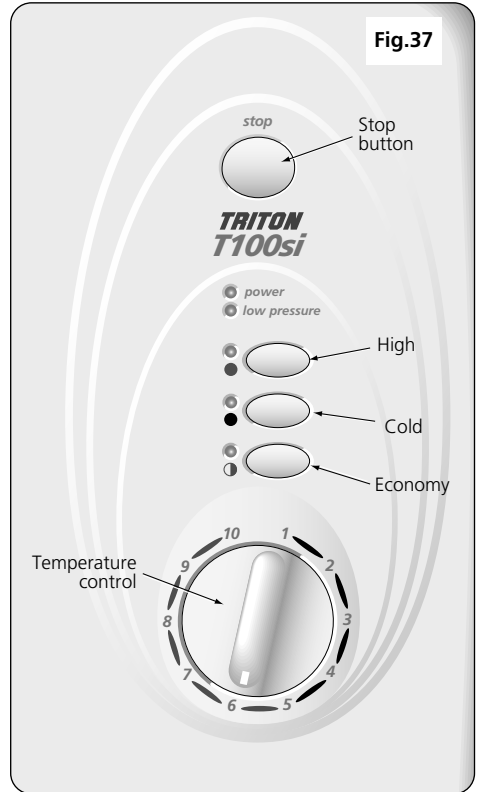

NOTE: IN NORMAL USE, IT IS IN ORDER TO LEAVE THE WATER SUPPLY PERMANENTLY ON TO THE SHOWER UNIT, BUT AS WITH MOST ELECTRICAL APPLIANCES, **THE UNIT MUST BE SWITCHED OFF AT THE ISOLATING SWITCH WHEN NOT IN USE.**

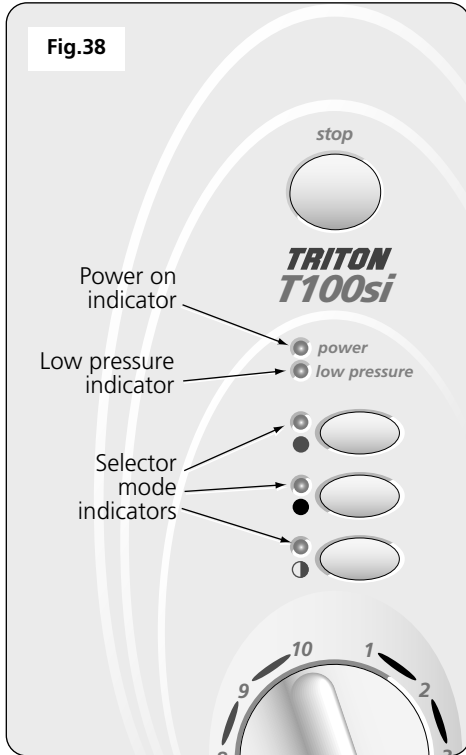

changes in ambient water temperature.

NOTE: The preferred number on 'economy' will give a different temperature to the same number position on 'high'.

To decrease the shower temperature

Turn the temperature control anti-clockwise; this will increase the flow of water through the shower and is indicated by lower numbers.

To increase the shower temperature

Turn the temperature control clockwise; this will decrease the flow of water through the shower and is indicated by higher numbers.

NOTE: It is advisable to be certain that the showering temperature is satisfactory by testing with your hand *before* stepping under the sprayhead. There will always be a time delay of ten to fifteen seconds between selecting a flow rate and the water reaching the stable temperature for that flow rate.

Caution: It is recommended that persons who may have difficulty understanding or operating the shower controls should not be left unattended whilst showering. Special consideration should be given to young children and the less able bodied.

WARNING: After any servicing of mains water supply, always ensure the unit is started on COLD in order to purge any air in the pipework.

OPERATING FUNCTIONS

Power on indicator (fig.38)

When the electricity supply to the shower is switched on at the isolating switch, the POWER indicator will light.

Low pressure indicator (fig.38)

If this indicator lights, this means the water pressure has fallen below the minimum required for correct operation of the shower, resulting in the low pressure cut-out operating. This switches off power to the heating elements preventing any maintained temperature rises (water will continue to flow). Power will automatically be restored when adequate water pressure returns.

Selector mode indicators (fig.38)

Adjacent to each control button there is an indicator that lights when the button is pressed, visually indicating which shower mode is in operation.

Phased shutdown

In use, when the stop button is pressed, power is switched off to the elements. Water will continue to flow for a few seconds, flushing out any remaining hot water. This ensures the next immediate user will not receive a slug of hot water if standing under the sprayhead when starting the shower.

Temperature limiter

During normal operation if an overheat temperature is sensed, power to the elements will be reduced. Water will continue to flow. When the temperature has cooled sufficiently, power to the elements will be automatically restored to the previous setting at the time of interruption.

Safety cut-out

The unit is fitted with a non re-settable thermal cut-out safety device. In the event of abnormal operation which could cause unsafe temperatures within the unit, the device will disconnect the heating elements. It will require a visit from a qualified engineer to determine the nature of the fault and replace the safety device, once the unit has been repaired.

ADJUSTING THE SPRAYHEAD

Four sprayhead patterns are available (**fig.39**). Adjustment is by turning the bezel on the sprayhead in either direction until the desired pattern is obtained.

MAXI

A full spray perfect for a relaxing shower.

ULTRA

A focused spray for a refreshing, satisfying shower.

NEEDLE

A tingling, fine spray for a highly invigorating shower.

JET

A concentrated spray for an exhilarating shower.

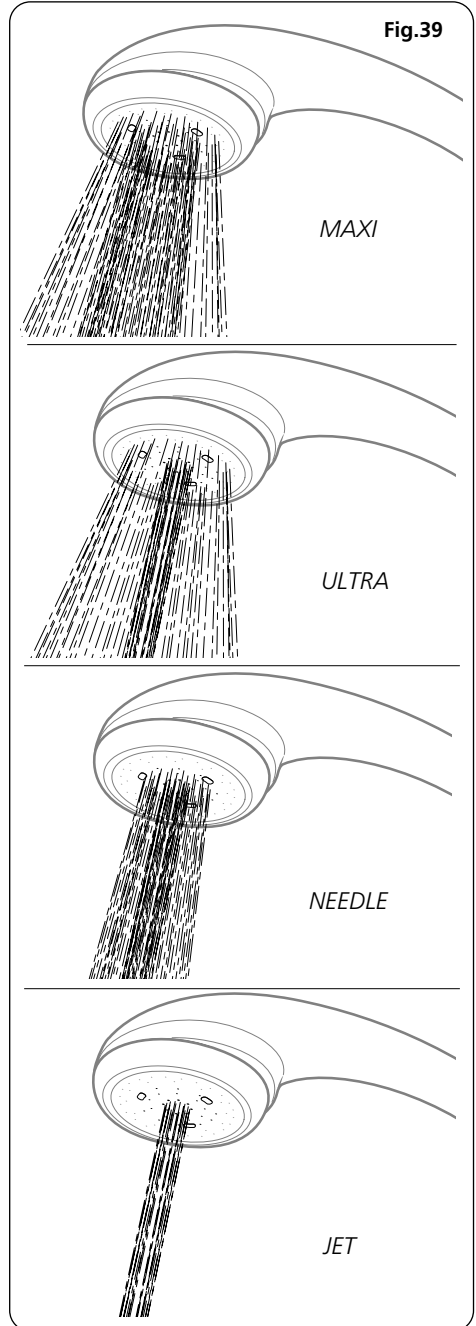

CLEANING

Do not use abrasive or solvent cleaning fluids. The shower unit, riser rail, hose, etc. should be cleaned using a soft cloth and warm water.

It is advised before cleaning, to turn the isolation switch off, thus avoiding the shower being accidentally switched on.

IT IS IMPORTANT TO KEEP THE SPRAYHEAD CLEAN TO MAINTAIN THE PERFORMANCE OF THE SHOWER. The hardness of the water will determine the frequency of cleaning. For example, if the shower is used every day in a very hard water area, it may be necessary to clean the sprayhead on a weekly basis.

Sprayplate removal

There is no need to remove the sprayhead from the hose.

Using the removal tool supplied (**fig.40**), locate the three raised 'bosses' into the three recesses in the sprayplate. Hold in firmly and twist anti-clockwise (**fig.41**). This movement may turn the cartridge assembly as well until it reaches a 'stop'.

Hold the cartridge firmly and continue to twist anti-clockwise. Having loosened the sprayplate sufficiently, it can be unscrewed and removed completely (**fig.42**).

Clean the sprayplate with a suitable brush or preferably leave it to soak overnight in a mild proprietary descaler. Ensure all traces of scale are removed and thoroughly rinse in clean water afterwards.

Before replacing the sprayplate, switch the power back on at the isolating switch and direct the hose and sprayhead to waste.

Turn the temperature control fully anti-clockwise.

Press the 'COLD' button.

This operation will flush out any loose scale deposits in the unit and sprayhead. Stop after approximately thirty seconds.

Refit the sprayplate by screwing clockwise. Use the tool to screw the sprayplate tight.

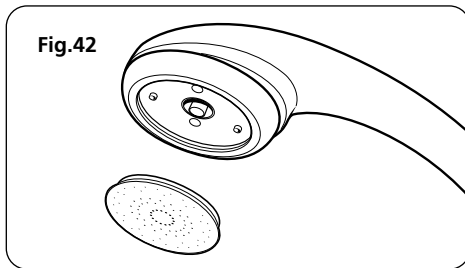
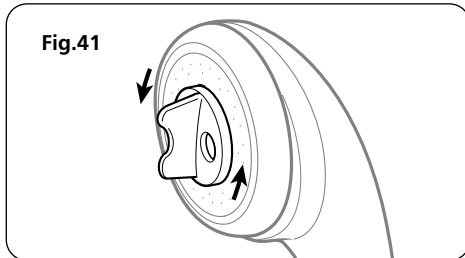
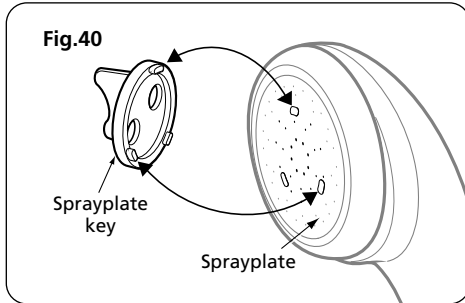

WARNING

Do not use 'powerful' abrasive or solvent cleaning fluids when cleaning the shower as they may damage the plastic fittings

CLEANING THE FILTER

The inlet filter is situated in the inlet pipe which is part of the solenoid valve (**fig.43**).

To gain access to the filter will require the trimplate to be removed and disconnecting and removal of the compression fitting. Also, depending on the incoming pipework arrangements, if there is not enough slack in the pipework, it could mean the removal of the unit from the wall.

When cleaning the wire mesh filter, **do not** use a sharp object, as it will cause damage. It is preferable to use an old toothbrush or similar.

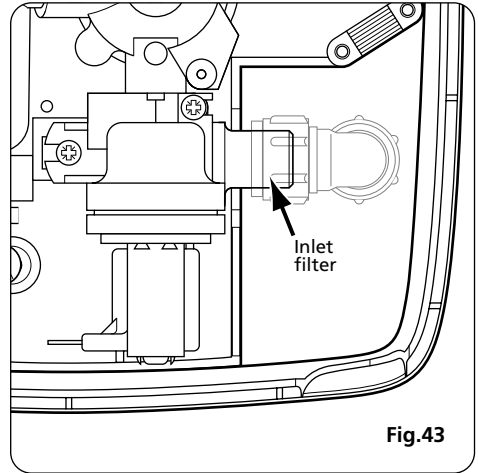
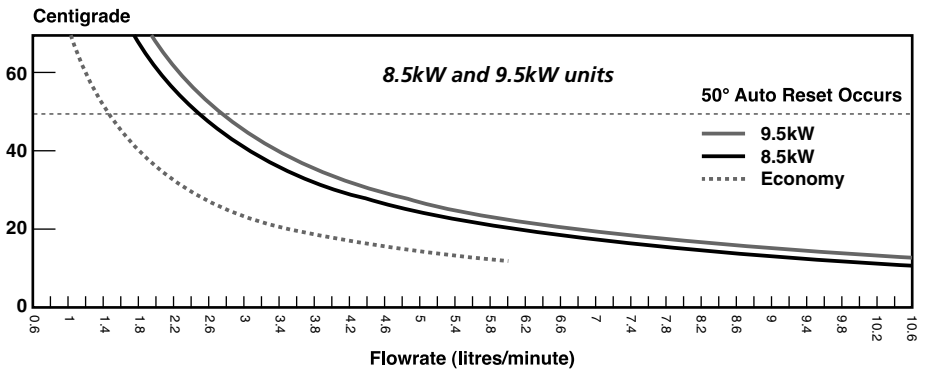
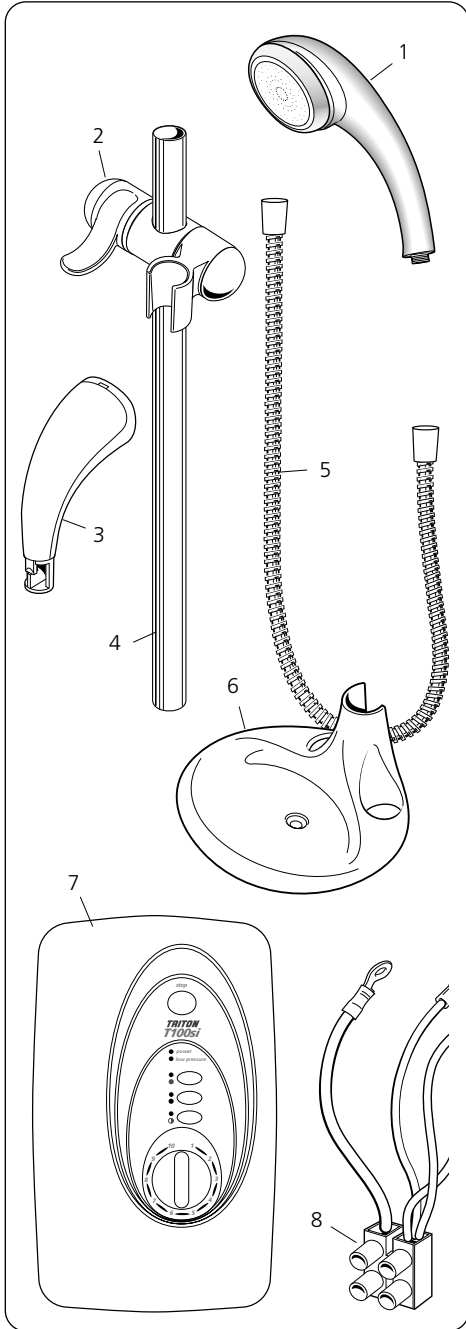

Fig.43

Temperature / flow rate graph (0° C ambient)





Ref	Description	Part No
1	4 mode sprayhead (all chrome)	22420120
2	Sprayhead holder	83306190
3	Brackets (pr.)	83306160
4	Riser rail	7042409
5	Flexible hose (chrome)	22007500
6	Soap dish (white)	22008960
7	Cover assembly	85100100
8	Terminal block & wires	82200280

Ref	Description	Part No
9	Heater can assembly 8.5kW 9.5kW	83304110 84500290
10	Thermal cut-out	22009860
11	PRD & 'O' ring	83301330
12	Stabiliser valve assembly	82600700
13	Outlet pipe assembly c/w wires	83304160
14	Solenoid valve assembly	83304130
15	Trimplate	7051656
16	Power PCB	7072052
17	Control PCB	7072060
-	Wire kit	83306330
-	TCO shield	7052871

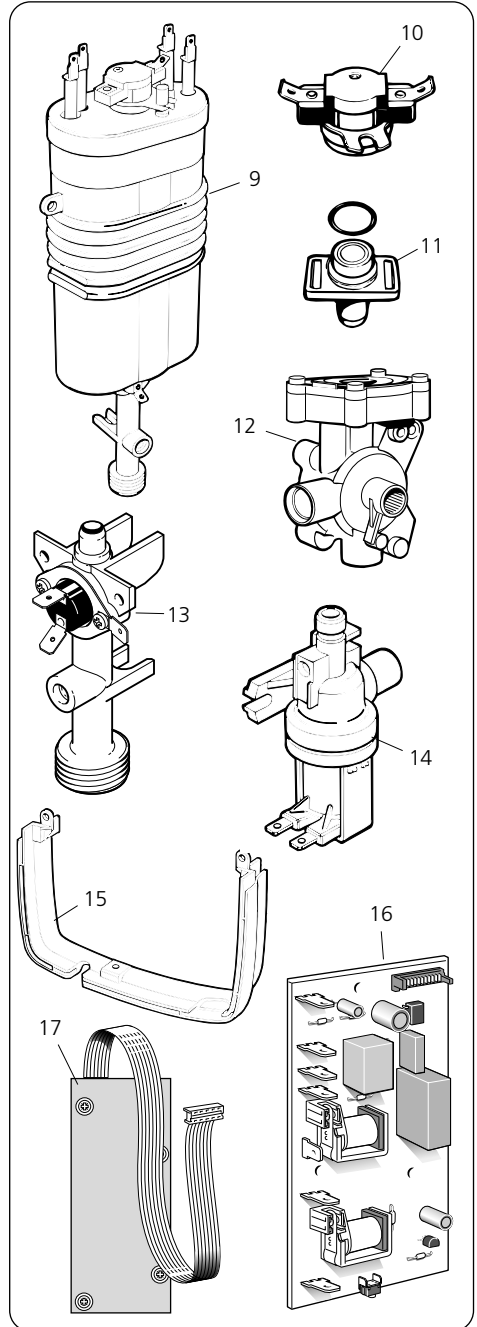

FAULT FINDING

IMPORTANT: Switch OFF the electricity at the mains supply and remove the circuit fuse before removing the cover from the shower while attempting any fault finding inside the unit.

<i>Problem/Symptom</i>	<i>Cause</i>	<i>Action/cure</i>
1 Shower inoperable, no water flow.	1.1 Interrupted power supply.	1.1.1 Blown fuse or circuit breaker. Check supply. Renew or reset fuse or circuit breaker. If it fails again, consult a qualified electrician. 1.1.2 Power cut? Check other appliances and if necessary, contact local Electricity Supply Co.
	1.2 Unit malfunction.	1.2.1 Have unit checked. Ring Customer Service.
2 Water too hot.	2.1 Not enough water flowing through the shower.	2.1.1 Increase the flow rate via temperature control. 2.1.2 Blocked sprayhead - clean blocked sprayplate.
	2.2 Blockage in supply.	2.2.1 Check if stop taps are fully open. Check if blockage in inlet filter.
	2.3 Increase in ambient water temperature.	2.3.1 Switch to economy power setting and re-adjust flow rate to give required temperature.
3 Water temperature cycling hot/cool at intervals.	3.1 Heater cycling on outlet temperature limiter.	3.1.1 See 'Water too hot' causes 2.1, 2.2 and 2.3 and their appropriate action/cures. If it continues, contact Customer Service.
4 Water too cool or cold.	4.1 Too much flow.	4.1.1 Reduce flow rate via temperature control.
	4.2 Water pressure below minimum stated on rating label.	4.2.1 Check low pressure indicator. If lit, continue with remainder of checks. If not lit, see 4.1 & 4.4.
		4.2.2 Is water supply mains or tank fed ?
		4.2.3 If tank fed, re-plumb to mains water supply or see 4.2.5. 4.2.4 If mains fed, ensure that mains stopvalve is fully open and that there are no other restrictions in the supply whilst shower is in use, or see 4.2.5. 4.2.5 Fit a pump to give minimum pressure – contact Customer Service for advice.
4.3 Reduction in ambient water temperature.	4.3.1 Switch to full power setting and re-adjust the flow rate via the temperature control to give required temperature.	
4.4 Electrical malfunction or safety cut-out has operated.	4.4.1 Have unit checked by suitably qualified electrician or contact Customer Service.	

FAULT FINDING (continued)

<i>Problem/Symptom</i>	<i>Cause</i>	<i>Action/cure</i>
5 Shower varies from normal temperature to cold during use.	5.1 Water pressure has dropped below minimum required. Indicator lit.	5.1.1 Wait until the water pressure resumes to normal. Low pressure indicator extinguishes.
6 Pressure relief device has operated (water ejected from PRD tube).	6.1 Blocked sprayhead.	6.1.1 Clean sprayplate and then fit a new PRD.
	6.2 Twisted/blocked flexible shower hose.	6.2.1 Check for free passage through hose. Replace hose if necessary and then fit new PRD.
	6.3 Sprayhead not removed whilst commissioning.	6.3.1 Fit new PRD. Commission unit with sprayhead removed.

Note: Identify cause of operation before fitting new PRD unit. When fitting a new PRD, follow the commissioning procedure.

It is advised all electrical maintenance/repairs to the shower should be carried out by a suitably qualified person.



*A **MORGROS** Company*

TRITON STANDARD GUARANTEE

Triton Plc guarantee this product against all mechanical and electrical defects arising from faulty workmanship or materials for a period of two years for domestic use only, from the date of purchase, provided that it has been installed by a competent person in full accordance with the fitting instructions.

Any part found to be defective during this guarantee period we undertake to repair or replace at our option without charge so long as it has been properly maintained and operated in accordance with the operating instructions, and has not been subject to misuse or damage.

This product must not be taken apart, modified or repaired except by a person authorised by Triton Plc. This guarantee applies only to products installed within the United Kingdom and does not apply to products used commercially.

This guarantee does not affect your statutory rights.

What is not covered:

1 Breakdown due to: **a)** use other than domestic use by you or your resident family; **b)** wilful act or

neglect; **c)** any malfunction resulting from the incorrect use or quality of electricity, gas or water or incorrect setting of controls; **d)** faulty installation.

2 Repair costs for damage caused by foreign objects or substances.

3 Total loss of the product due to non-availability of parts.

4 Compensation for loss of use of the product or consequential loss of any kind.

5 Call out charges where no fault has been found with the appliance.

6 The cost of repair or replacement of pressure relief devices, sprayheads, hoses, riser rails and/or wall brackets, isolating switches, electrical cable, fuses and/or circuit breakers or any other accessories installed at the same time.

7 The cost of routine maintenance, adjustments, overhaul modifications or loss or damage arising therefrom, including the cost of repairing damage, breakdown, malfunction caused by corrosion, furring, pipe scaling, lime scale, system debris or frost.

Service Policy

In the event of a complaint occurring, the following procedure should be followed:

1 Telephone Customer Service on (024) 7637 2222 (08457 626591 in Scotland and in Northern Ireland), having available the model number and power rating of the product, together with the date of purchase.

2 Triton Customer Service will be able to confirm whether the fault can be rectified by either the provision of a replacement part or a site visit from a qualified Triton service engineer.

3 If a service call is required it will be booked and the date of call confirmed. In order to expedite your request, please have your postcode available when booking a service call.

4 It is essential that you or an appointed representative (who must be a person of 18 years of age or more) is present during the service engineer's visit and receipt of purchase is shown.

5 A charge will be made in the event of an aborted service call by you but not by us, or where a call under the terms of guarantee has been booked and the failure is not product related (i.e. scaling and furring, incorrect water pressure, pressure relief device operation, electrical installation faults).

6 If the product is no longer covered by the guarantee, a charge will be made for the site visit and for any parts supplied.

7 Service charges are based on the account being settled when work is complete, the engineer will then request payment for the invoice. If this is not made to the service engineer or settled within 10 working days, a £10 administration charge will be added.

Replacement Parts Policy

Availability: It is the policy of Triton to maintain availability of parts for the current range of products for supply after the guarantee has expired. Stocks of spare parts will be maintained for the duration of the product's manufacture and for a period of five years thereafter.

In the event of a spare part not being available a substitute part will be supplied.

Payment: The following payment methods can be used to obtain spare parts:

1 By post, pre-payment of pro forma invoice by cheque or money order.

2 By telephone, quoting credit card (MasterCard or Visa) details.

3 By website order, www.tritonshowers.co.uk

Triton Plc, Shepperton Park, Caldwell Road,
Nuneaton, Warwickshire. CV11 4NR

Customer Service

☎ (024) 7637 2222

Scottish and Northern Ireland

Customer Service

☎ 08457 626591

Trade Installer Hotline

☎ (024) 7632 5491

Fax: (024) 7632 4564

www.tritonshowers.co.uk

E mail: technical@triton.plc.uk