

TRITON

. T80si electric shower .



Installation and Operating Instructions

INSTALLERS PLEASE NOTE THESE INSTRUCTIONS ARE TO BE LEFT WITH THE USER

CONTENTS	Page
Important safety information	1
Introduction	2
Advice to users	2
Key to main components	3
Site requirements	4
Siting of the shower	5
Fitting the shower to the wall	6
Plumbing connections	6 - 7
Electrical connections	8
Replacing the cover	9
Fitting the riser rail	10
Fitting the hose and sprayhead	11
Commissioning	12
Operating the shower	13 - 14
Operating functions	14 - 15
Adjusting the sprayhead	15
User maintenance	16
Fault finding	17
Spare parts	18 - 19
Volts and amperage reference	20
Guarantee, service policy, etc.	rear cover

PLEASE READ THIS IMPORTANT SAFETY INFORMATION

- ◆ Products manufactured by Triton are safe and without risk provided they are installed, used and maintained in good working order in accordance with our instructions and recommendations.
- ◆ DO NOT operate the unit if it is frozen, or suspected of being frozen. It must thaw out before using.
- ◆ DO NOT operate the unit if the sprayhead or spray hose becomes damaged.
- ◆ DO NOT restrict flow out of the shower by placing the sprayhead in direct contact with your body.
- ◆ DO NOT operate the unit if: **a)** water ceases to flow during use. **b)** the shower begins to make odd noises, smell or smoke. **c)** water has entered inside the unit because of an incorrectly fitted cover.

1 GENERAL

- 1.1 Isolate the electrical and water supplies before removing the cover.
- 1.2 Read all of these instructions and retain them for later use.
- 1.3 DO NOT take risks with plumbing or electrical equipment.
- 1.4 Isolate electrical and water supplies BEFORE proceeding with the installation.
- 1.5 The unit must be mounted onto the finished wall surface (on top of the tiles). DO NOT tile up to unit after fixing to wall.
- 1.6 Contact Customer Service (see back page), if any of the following occur;
 - a) If it is intended to operate the shower in areas of hard water, a scale inhibitor will have to be fitted.
 - b) If it is intended to operate the shower at pressures above the maximum or below the minimum stated.
 - c) If the unit shows a distinct change in performance.
 - d) If the shower is frozen.
- 1.7 The sprayplate and cartridge must be cleaned regularly with descalent to remove scale and debris, otherwise restrictions to the flow on the outlet of the unit will result in higher temperatures and could also cause the Pressure Relief Device in the unit to operate.
- 1.8 This product is not suitable for mounting into steam rooms or steam cubicles.

2 PLUMBING

- 2.1 The plumbing installation must comply with Water Supply Byelaws, Building Regulations or any particular regulations as specified by Local Water Company or Water Undertakers Byelaws.
- 2.2 The supply pipe must be flushed to clear debris

before connecting the shower unit (Byelaw 55).

- 2.3 DO NOT solder pipes or fittings within 300mm of the shower appliance, as heat transfer can damage components.
- 2.4 DO NOT fit any form of outlet flow control as the outlet acts as a vent for the heater can.
- 2.5 DO NOT use excessive force when making connections to the flexible hose or sprayhead, finger tightness is sufficient.
- 2.6 All plumbing connections MUST be completed BEFORE making the electrical connections.

3 ELECTRICAL

- 3.1 The installation must comply with BS 7671 'Requirements for electrical installations' (IEE wiring regulations) or any particular regulations as specified by the local Electrical Supply Company.
- 3.2 This appliance MUST be earthed.
- 3.3 In accordance with 'The Plugs and Sockets etc. (Safety) Regulations 1994', this appliance is intended to be permanently connected to the fixed wiring of the electrical mains system.
- 3.4 Ensure all electrical connections are tight to prevent overheating.
- 3.5 Fuses do not give personal protection against electric shock.
- 3.6 *In the interest of electrical safety* a 30mA residual current device (RCD) should be installed in all UK electric and pumped shower circuits. This may be part of the consumer unit or a separate unit.
- 3.7 Switch off immediately at isolating switch if water ceases to flow during use.
- 3.8 Other electrical equipment i.e. extractor fans, pumps must not be connected to the circuits within the unit.
- 3.9 Switch off at isolating switch when not in use.

INTRODUCTION

This book contains all the necessary fitting and operating instructions for your Triton T80si electric shower. Please read them carefully. *The shower installation must be carried out by a suitably qualified person and in the sequence of this instruction book.*

Care taken during the installation will ensure a long, trouble-free life from your shower.

SPECIFICATIONS

Electrical

Nominal power rating at 240V	Nominal power rating at 230V
7.5kW – (32A MCB rating)	7.0kW – (32A MCB rating)
8.5kW – (40A MCB rating)	7.9kW – (40A MCB rating)
9.5kW – (40A MCB rating)	8.8kW – (40A MCB rating)

Water

Inlet connection – 15mm diameter.
Outlet connection – 1/2" BSP male thread.

Entry Points

Water – top, bottom, back, left or right.
Cable – top, bottom, back, left or right.

Materials

Backplate, cover, controls, sprayhead – ABS.
Sprayplate – Acetal.
Elements – Minerally insulated corrosion resistant metal sheathing.

Dimensions

Height - 300mm
Width - 208mm
Depth - 110mm

Standards and Approvals

Triton is registered by the British Standards Institute to BS EN ISO 9001:1994.

Complies with the requirements of current British and European safety standards for household and similar electrical appliances.

Complies with requirements of the British Electrotechnical Approvals Board (BEAB).

Meets with Compliance with European Community Directives (CE).

ADVICE TO USERS

The following points will help you understand how the shower operates:

1 The electric heating elements operate at a constant rate at your chosen power setting. It is the flow rate of the water passing through the heater unit which determines the shower temperature at any given setting. (The slower the flow the hotter the water becomes, and the faster the flow the cooler the water).

2 During Winter, mains water supply will be cooler than in Summer. Therefore the temperature of the shower will vary between seasons on any one setting of the temperature control, e.g. if you have chosen setting number 6 as your preferred shower temperature in the Summer, you will have to increase that number during Winter by adjusting the temperature control clockwise (which in effect slows the water flow).

3 The stabiliser valve minimises variations in shower temperature during mains water pressure changes. If changes in shower temperature are experienced during normal use, it will most likely be caused by the water pressure falling near to or below the minimum level. The drop in pressure may be due to water being drawn off at other points in the house whilst the shower is in use. If pressure drops appreciably below the minimum, the heating elements will automatically cut out.

If ever the water becomes too hot and you cannot obtain cooler water, first check that the sprayplate in the sprayhead has not become blocked.

Replacement parts can be ordered from Customer Service. See '*spare parts*' for details and part numbers.

Due to continuous improvement and updating, specification may be altered without prior notice.

KEY TO MAIN COMPONENTS

Inside unit (fig.1)

- 1 Top cable/pipe entry
- 2 Wall screw fixings
- 3 Cover screw fixings
- 4 Thermal safety cut-out
- 5 Power selector assembly
- 6 Can and element assembly
- 7 Pressure switch/flag assembly
- 8 Stabilising valve
- 9 Terminal block
- 10 Earth connection
- 11 Solenoid valve
- 12 Water inlet
- 13 Thermal cut-out (outlet)
- 14 Pressure relief device (PRD)
- 15 Shower outlet

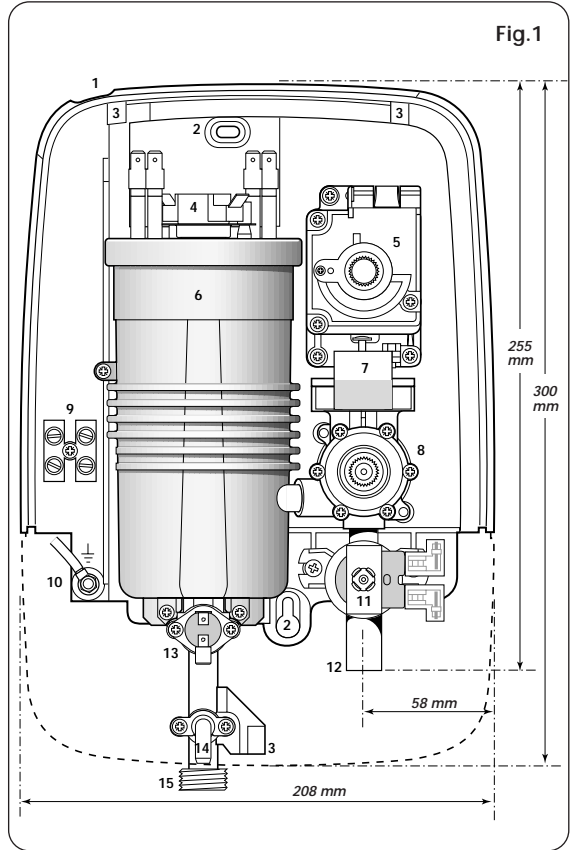

Inside cover (fig.1a)

- 16 Stop/start switch

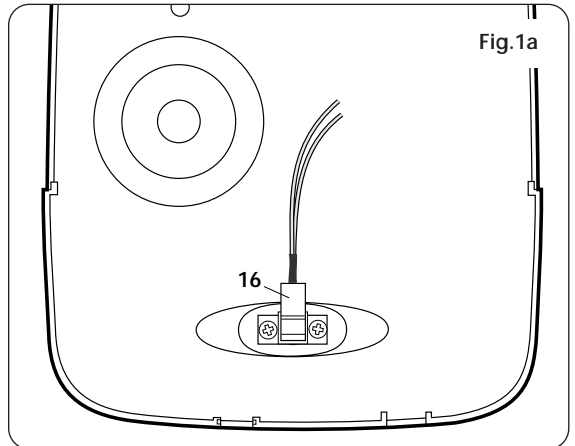

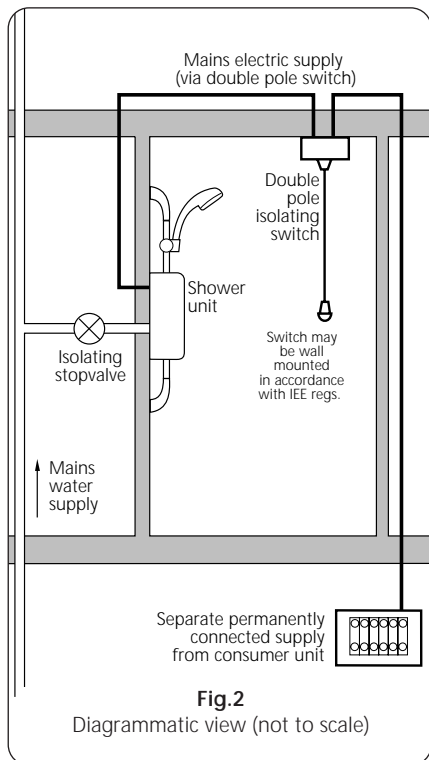

SITE REQUIREMENTS

Water: The installation must be in accordance with local Water Company Byelaws. To ensure activation of the heating elements, the shower must be connected to a mains water supply with a minimum running pressure of 1.0 bar (14.5 psi) at a minimum flow rate of 8 litres/minute (9 litres/minute for 9.5kW model) and a maximum static pressure of 10 bar (145 psi). NOTE: If the stated flow rates are not available, it may not be possible to achieve optimum performance from the unit throughout the year. During periods of high ambient temperatures it may be necessary to select a low power setting to achieve your desired shower temperature. The water supply can be taken from a cold water storage cistern *provided* there is a minimum head of 10 m above the sprayhead. It must be an independent supply to the shower only. If it is intended to operate the shower in hard water areas or at pressures above the maximum or below the minimum stated, contact Customer Service for advice.

Figure 2 shows a typical system layout. *Do not* use jointing compounds on any pipe fittings for the installation.

Electrical: The installation must comply with current IEE wiring regulations. A separate permanently connected supply must be taken from the consumer unit to the shower via a double pole linked switch with a minimum contact gap of 3mm in both poles. The switch can be a ceiling mounted pullcord type or a wall mounted switch. The switch must be readily accessible and clearly identifiable, but out of reach of a person using a fixed bath or shower, except for the cord of a cord operated switch. The wiring must be connected to that switch without the use of a plug or socket outlet. NOTE: Where shower cubicles are located in rooms other than bathrooms, any socket outlet in that room must be situated at least 2.5 metres from the shower cubicle. The supply cable and circuit protection must conform with current IEE wiring regulations and be sufficient for the amperage required (see reference on page 20). If in any doubt consult a qualified electrician or contact Customer Service for advice.

Important: For close circuit protection DO NOT use a rewirable fuse. Instead use a suitably rated miniature circuit breaker (MCB) or cartridge fuse. In the interest of electrical safety a 30mA residual current device (RCD) should be installed in all UK electric and pumped shower circuits. This may be part of the consumer unit or a separate unit.

SITING OF THE SHOWER

WARNING: The shower must not be positioned where it will be subjected to freezing conditions.

FOR EASE OF SERVICING, THE UNIT MUST ALWAYS BE MOUNTED ON THE SURFACE OF TILED WALLS. NEVER TILE UP TO THE UNIT.

Refer to figure 3 for correct siting of shower. Position the unit where it will NOT be in direct contact with water from the sprayhead. Position the shower unit vertically.

Allow sufficient room between the ceiling and the shower to access the cover top screws.

NOTE: Water supply Byelaw 17 (shower hose connections) requires the sprayhead be 'constrained by a fixed or sliding attachment so that it can only discharge water at a point not less than 25mm above the spill-over level of the relevant bath, shower tray or other fixed appliance'. The use of the supplied soap dish will in most cases meet this requirement, but if the sprayhead can be placed within a bath, basin or shower tray, then a double check valve, or similar, must be fitted in the supply pipework to prevent back-flow.

Pressure relief safety device

A pressure relief device (PRD) is designed into the shower unit which complies with European standards. The PRD provides a level of appliance protection should an excessive build up of pressure occur within the shower. DO NOT operate the shower with a damaged or kinked shower hose, or a blocked sprayhead.

When commissioning, the sprayhead must be removed from the flexible hose, while at the same time the temperature control must be at the minimum flow position.

Ensure the shower is positioned over a bath or shower tray because if the PRD operates, then water will eject from the bottom of the unit. Should this happen, turn off the electricity and water supplies to the shower at the isolating switch and stopvalve. Contact Customer Service for advice on replacing the PRD.

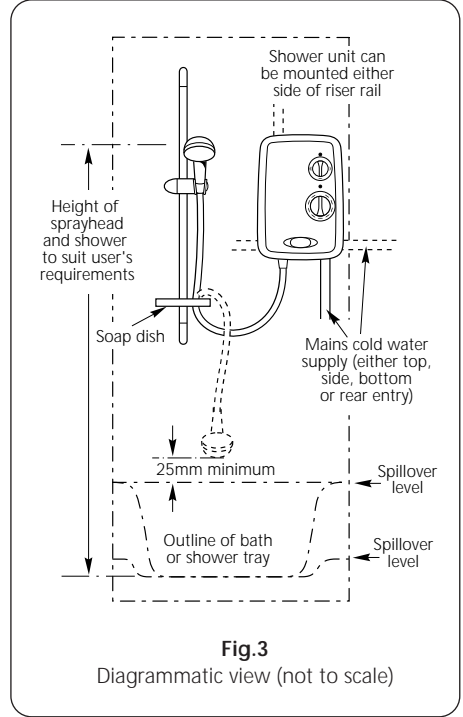

Important: The unit must be mounted on a flat surface which covers the full width and length of the backplate. It is important that the wall surface is flat otherwise difficulty may be encountered when fitting the cover and subsequent operation of the unit may be impaired.



FITTING THE SHOWER TO WALL

NOTE: The control knobs are an integral part of the cover – do not attempt to remove them.

Unscrew the two top and one bottom retaining screws (fig.4) and lift the cover from the backplate.

After choosing the site for the shower, use the backplate as a template and mark the two fixing holes (fig.5). Drill and plug to suit the fixing screws supplied.

Screw bottom fixing screw into position leaving the base of the screw head protruding 6mm (0.25in) out from the wall.

Hook the backplate over the bottom screw and fit the top fixing screw into position.

Do not fully tighten the screws at this stage, as the fixing holes are elongated to allow for out of square adjustment after the plumbing connections have been completed.

PLUMBING CONNECTIONS

Plumbing to precede wiring.

WARNING: The outlet of the shower acts as a vent and must not be connected to any tap or fitting not recommended by Triton Plc.

DO NOT use jointing compounds on any pipe fittings for the installation.

DO NOT use soldered fittings within the vicinity of the shower unit.

Compression fittings **MUST** be used to connect to the inlet of the shower. (Push-on fittings must not be used as full engagement cannot be guaranteed).

NOTE: An additional stopvalve (complying with Water Byelaws) **MUST** be fitted in the mains water supply to the shower as an independent means of isolating the water in order to carry out maintenance or servicing.

Entry positions for the mains water and electric cable are from the top, bottom, either side or from the back.

NOTE: Deviations from the designated entry points will invalidate product approvals.

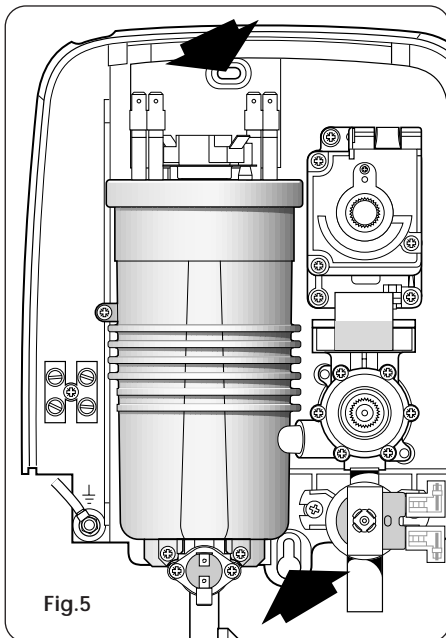

Procedure

Turn off water supply either at the mains stopvalve or the isolating stopvalve. Connect the mains water supply to the inlet of the shower via 15mm copper, stainless steel or plastic pipe using a 15mm x 15mm compression fitting.

If bottom entry has been chosen, fit the appropriate cut-out in the top of the backplate (fig.6).

If top entry has been chosen, fit the appropriate cut-out in the bottom of the cover (fig.7).

If side entry is required, the cover will have to be cut out. Carefully remove the appropriate area by using a knife or junior hacksaw (fig.8).

If installing a feed pipe from the back or bottom, the centre of the inlet valve to the wall surface is 20mm (fig.9).

NOTE: If entry is from the back, the nut of the compression fitting will be partially behind the surface of the wall (fig.9). This area **MUST** be left clear when plastering over the pipework in order to make the nut accessible for future adjustments.

DO NOT use excessive force when making these connections.

Important: Before completing the connection of the water supply to the inlet of the shower, and in compliance with Water Byelaw 55, flush out the pipework to remove all swarf and system debris. This can be achieved by connecting a hose to the pipework and turning on the mains water supply long enough to clear the debris to waste.

Ensure the backplate is square on the wall and tighten the two retaining screws which hold it to the wall.

Turn on the mains water supply and check for leaks in the pipework connection to the shower.

NOTE: At this stage no water can flow through the unit.

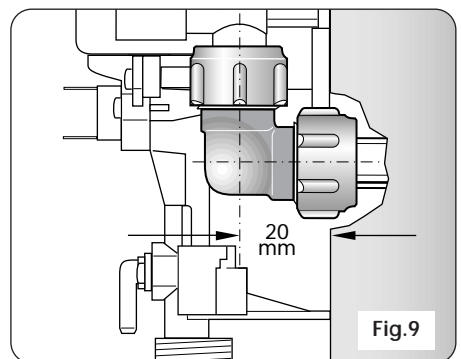
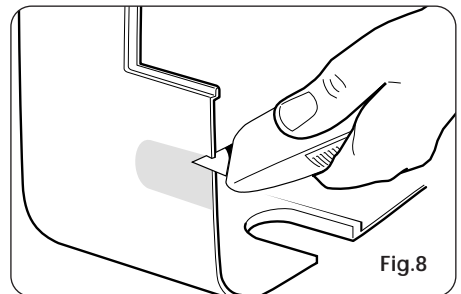
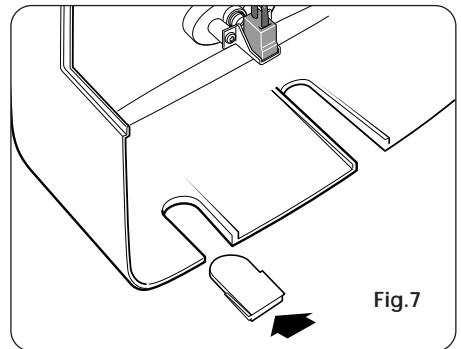
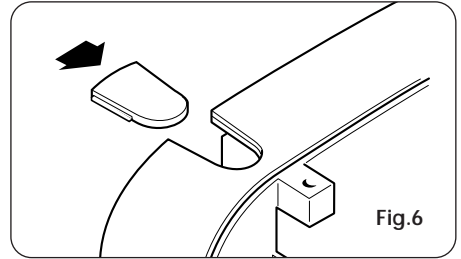
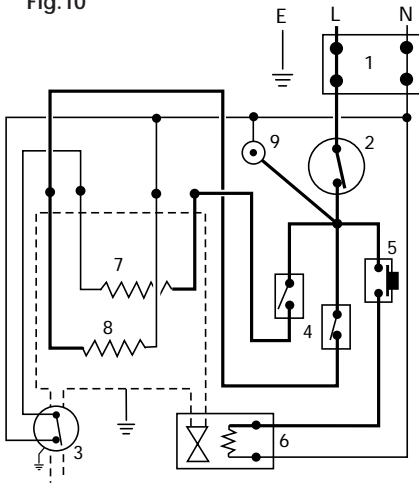

Fig.10



- | | |
|----------------------------|------------------|
| 1 Terminal block | 6 Solenoid valve |
| 2 Thermal cut-out (main) | 7 Element |
| 3 Thermal cut-out (outlet) | 8 Element |
| 4 Microswitches | 9 Neon |
| 5 Start/stop button | |

ELECTRICAL CONNECTIONS

WARNING: THIS UNIT MUST BE EARTHED.

NOTE: A double pole linked switch with a minimum contact gap of 3mm in both poles must be fitted in the circuit. The supply cable must conform to relevant tables in current IEE regulations. The electrical rating of the shower is shown on the rating label within the unit. Figure 10 shows a schematic wiring diagram.

SWITCH OFF THE ELECTRICITY SUPPLY.

The cable entry points are shown in figure 1. The cable can be surface clipped, hidden or via 20mm conduit. **NOTE:** Conduit entry can only be from rear. Route the cable into the shower unit and connect to the terminal block (fig. 11) as follows:-

Live cable to terminal marked L

Neutral cable to terminal marked N

Earth cable to terminal marked E 

Important: Fully tighten the terminal block screws and ensure that no cable insulation is trapped under the screws.

NOTE: The supply cable earth conductor must be sleeved. The outer sheath of the supply cable must be stripped back to the minimum.

If a cable larger than 10 mm² is used, the cable must be secured either by routing through conduit or in trunking or by embedding in the wall, in accordance with current IEE regulations.

The earth continuity conductor of the electrical installation must be effectively connected electrically to all exposed metal parts of other appliances and services in the room in which the shower is to be installed, to conform to current IEE regulations.

The use of connections within the unit to supply power to other equipment i.e. extractor fans, pumps etc. will invalidate the guarantee.

Fig.11

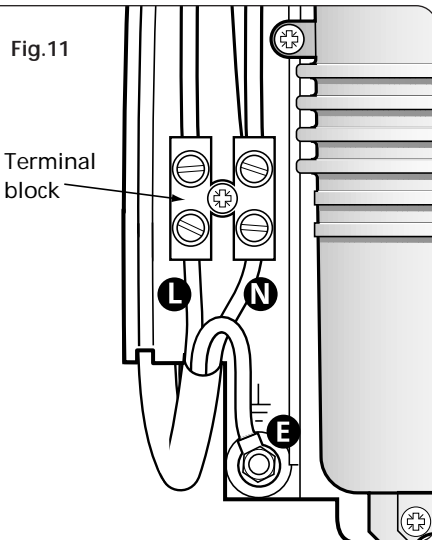

DO NOT switch on the electricity supply until the cover has been fitted.

REPLACING THE COVER

The power selector spindle must be aligned as shown (fig.12)

To ensure that the temperature control is correctly positioned on the stabilising valve, temporarily place the cover in position so that the splines engage and rotate the temperature control fully anti-clockwise.

Remove the cover and position the temperature control knob so that it points towards the No.1 position (fig.13). Position the power selector to the 'COLD' position (fig.14).

Offer the cover to the backplate unit. Attached to the stop/start switch inside the cover is a two wire lead. The socket on the end of this lead must be connected to the plug that is situated at the bottom of the right hand side of the backplate unit (fig.15). NOTE: The plug and socket can only fit one way.

Replace the cover squarely to the backplate and guide into position so that the knobs locate correctly into the splined spindles while at the same time, ensuring wires are not trapped.

Should any difficulty arise, re-check the points above.

Secure the cover in position with the three retaining screws.

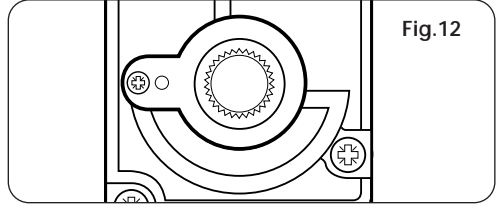

Fig.12

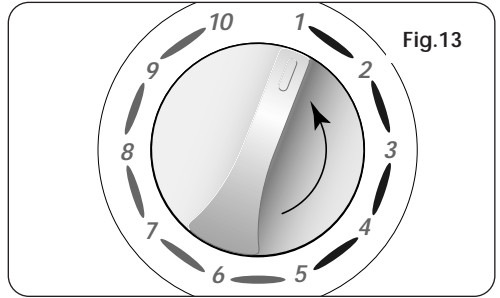

Fig.13

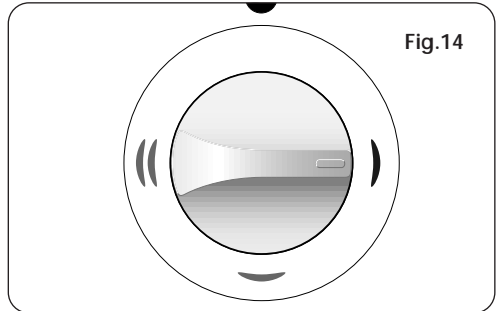

Fig.14

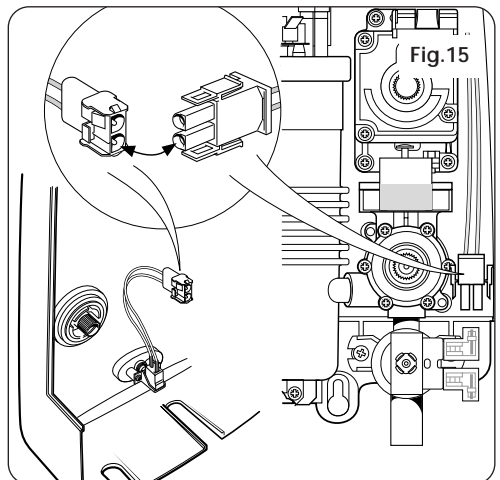

Fig.15

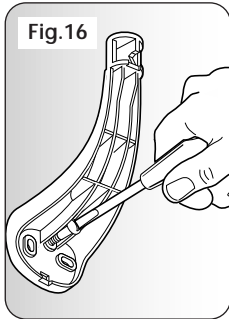

Fig. 16

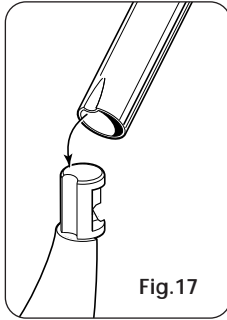

Fig. 17

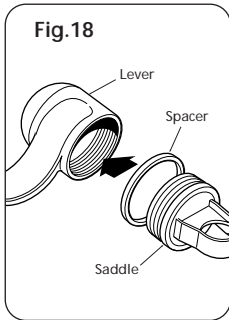

Fig. 18

Lever

Spacer

Saddle

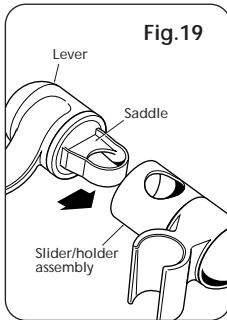

Fig. 19

Lever

Saddle

Slider/holder assembly

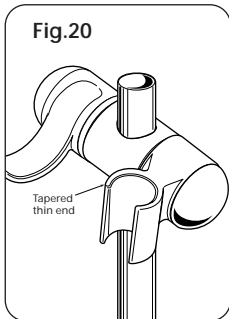

Fig. 20

Tapered thin end

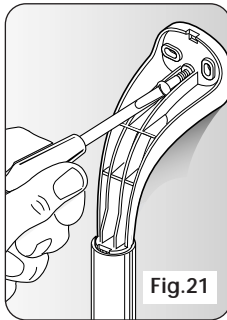

Fig. 21

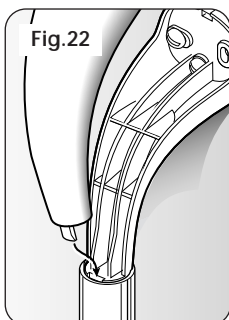

Fig. 22

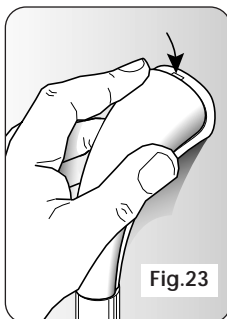

Fig. 23

FITTING THE RISER RAIL

WARNING: Check there are no hidden cables or pipes before drilling holes for wall plugs. Use great care when using power tools near water. The use of a residual current device (RCD) is recommended.

Decide the position for the rail on the wall within the shower area. Proceed as follows:

A Offer one of the two brackets to the wall for the lower position only. Note there are three holes in the brackets but two screws will usually be sufficient. However, the centre hole must be used so mark this and either of the other two. Drill and plug the wall. Replace the bracket to the wall and secure to the wall with the screws supplied (fig. 16). Locate the rail onto this lower bracket ensuring the rail engages fully on the bracket. Ensure the indent in the riser rail engages into the cut-out on the bracket end (fig. 17).

B Locate the second bracket on top of the rail. Again mark the centre hole plus one of the other two holes. Ensure the rail is vertical. Remove the bracket and rail. Drill and plug the wall.

C With the saddle, spacer and lever parts to hand, screw the saddle 2 or 3 turns into the lever (fig. 18). Place the saddle and lever into the slider/holder assembly (fig. 19) so that the holes align, then slide onto the rail (fig. 20). Tighten to the rail by turning the lever. When tight, the lever should be facing forwards and not pointing to the wall. If not, slacken off and remove from the rail. Rotate the saddle and lever 180° within the slider/holder assembly then replace onto the rail and tighten. Ensure the tapered thin end of the spray head holder is in the uppermost position.

D Place the rail onto the installed lower bracket. Replace the upper bracket onto the

rail and secure the bracket to the wall with the screws supplied (fig.21).

E Place a trim cover onto each bracket ensuring the large protrusion at the narrow end of the trim cover, engages into the slot between the rail and bracket (fig.22) before pushing and clicking the other end into place (fig.23). Should the need arise, the trim covers can be removed by inserting a screwdriver into the slot and carefully levering off the trim.

F Snap the soap dish onto the rail (fig.24) below the holder assembly. Prise open the soap dish collar and fit onto the rail (fig.25) below the dish. Note the collar is slightly tapered and should be fitted 'thinner section' uppermost. Ensure it locates firmly in the soap dish (fig.26) so that it holds the dish at the required height on the rail.

FITTING THE HOSE AND SPRAYHEAD

Feed the flexible hose through the appropriate soap dish aperture (fig.27) in order that the dish acts as a retaining ring (Water Supply Byelaw 17).

Screw the flexible hose to the shower outlet and sprayhead (fig.28) ensuring the supplied washers are in place at both ends of the flexible hose.

Place the sprayhead into the holder (fig.29) and check that it fits correctly. NOTE: The holder is slightly tapered and the sprayhead and hose will only fit from one direction.

Important: It is the conical end of the hose which grips into the holder. The sprayhead will not fit in the holder without the hose attached.

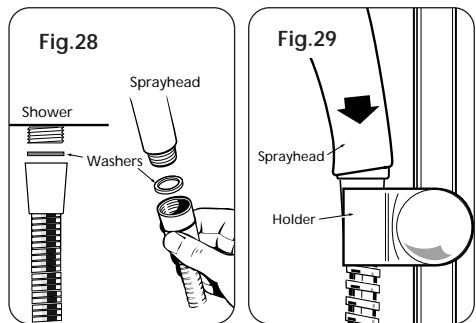
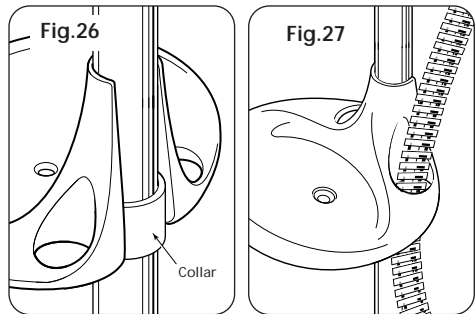
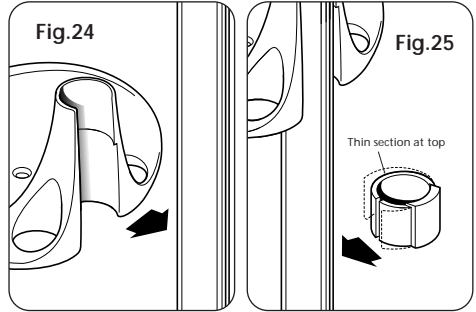

Fig.30

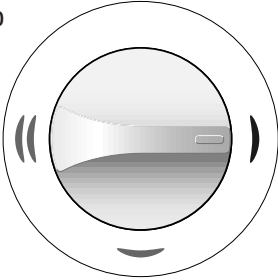

Fig.31

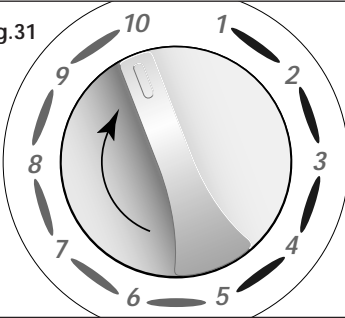

Fig.32

start / stop

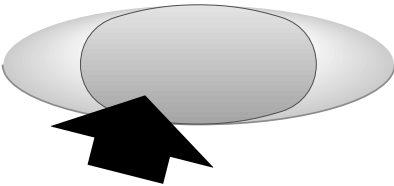
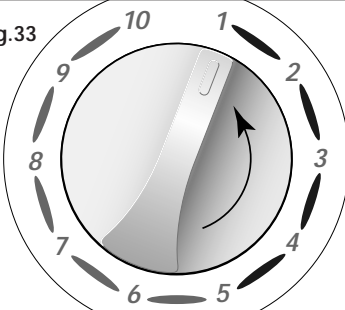

Fig.33



COMMISSIONING

The first operation of the shower is intended to flush out any remaining unit debris, and to ensure the heater unit contains water before the elements are switched on. This operation must be carried out with the flexible hose screwed to the outlet but *without* the sprayhead attached. The 'COLD' position must be used. Ensure the outlet of the flexible hose is directed to waste.

NOTE: Ensure the 'START/STOP' button is not depressed in the cover which indicates 'start'. The button should be flush with the cover, otherwise water will flow as soon as the electricity is switched on.

Before turning on the electric and mains water supplies to the shower, ensure that the power selector is at the 'COLD' position (fig.30) and the temperature control is rotated fully clockwise to '10', the minimum flow position (fig.31).

NOTE: Failure to turn the control to '10' may cause the PRD to operate.

Turn on the mains water supply to the shower at the isolating stop valve and then turn on the electric supply to the shower at the isolating switch. The power indicator will light.

Press the 'START/STOP' button (fig.32) and wait until water starts to flow from the flexible hose.

Slowly rotate the temperature control fully anti-clockwise to '1', the maximum flow position (fig.33).

It will take approximately 30 seconds for a smooth flow of water to be obtained whilst air and debris is being dispersed from the shower.

When a smooth flow of water is obtained, rotate the temperature control from '1' to '10' several times to release any trapped air within the unit.

Once flushing out has been completed, stop the water flow by pressing the 'START/STOP' button.

Fit the sprayhead to the flexible hose and place in the sprayhead holder. The shower is now ready for normal operation.

OPERATING THE SHOWER

NOTE: Ensure the commissioning procedure has been carried out.

To start the shower

Press the 'START/STOP' button and water will flow.

To stop the shower

Press the 'START/STOP' button and water will cease to flow. NOTE: If re-starting immediately after stopping, be aware that a slug of hot water will be expelled for the first few seconds.

To use the power selector

The power selector has three positions (cold, economy and high) as shown in fig.34.

Blue symbol is cold water only. Adjustment of the temperature control at this setting will only alter the force of the water from the sprayhead. IT WILL NOT ALTER THE WATER TEMPERATURE.

Single red symbol is an economy setting for using less power when the ambient mains water temperature is high during hot months. Temperature adjustment at this setting is via the temperature control.

NOTE: If the stated flow rate required for the unit cannot be met due to low water pressure, it will be necessary to operate the unit on this setting during the warmer months because of flow rate limitations entering the unit.

Double red symbol is a high setting which allows the highest flow achievable for your preferred temperature. This setting should normally be regarded as optimum shower performance throughout the year. Temperature adjustment at this setting is via the temperature control.

To adjust the shower temperature

The water temperature is altered by increasing or decreasing the flow rate of the water through the shower via the temperature control (fig.34).

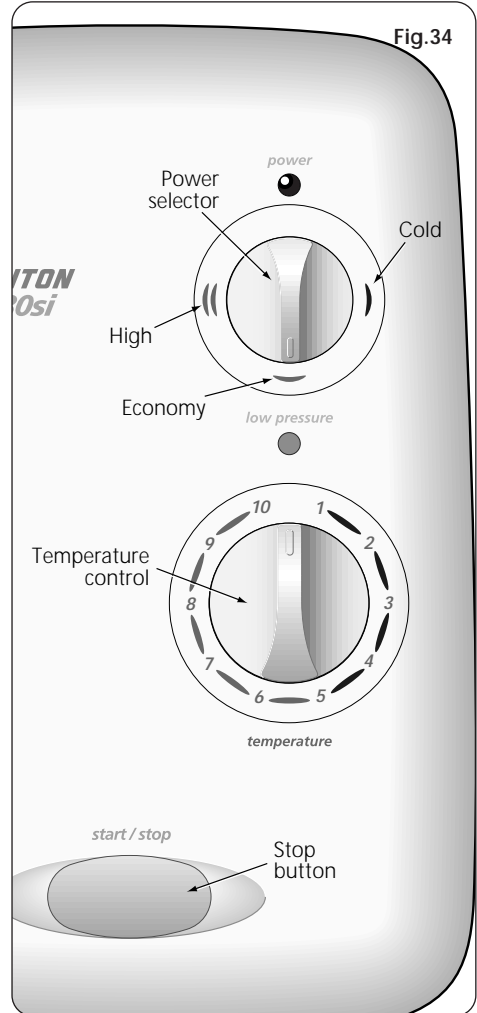

NOTE: IN NORMAL USE, IT IS IN ORDER TO LEAVE THE WATER SUPPLY PERMANENTLY ON TO THE SHOWER UNIT, BUT AS WITH MOST ELECTRICAL APPLIANCES, **THE UNIT MUST BE SWITCHED OFF AT THE ISOLATING SWITCH WHEN NOT IN USE.**

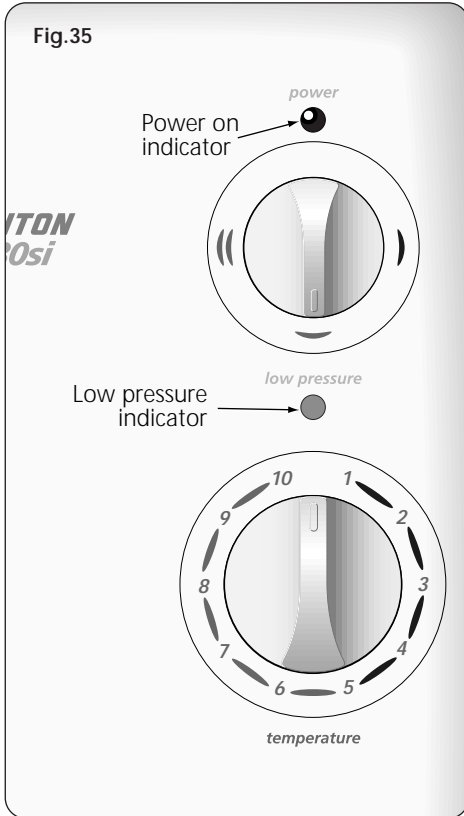

After obtaining your preferred shower temperature, the number can be remembered and left as the normal setting and should only need to be altered to compensate for seasonal changes in ambient water temperature.

NOTE: The preferred number on 'economy' will give a different temperature to the same number position on 'high'.

To decrease the shower temperature

Turn the temperature control anti-clockwise; this will increase the flow of water through the shower and be indicated by the lower numbers.

To increase the shower temperature

Turn the temperature control clockwise; this will decrease the flow of water through the shower and be indicated by the higher numbers.

NOTE: It is advisable to be certain that the showering temperature is satisfactory by testing with your hand before stepping under the sprayhead. There will always be a time delay of 10 to 15 seconds between selecting a flow rate and the water reaching the stable temperature for that flow rate.

CAUTION: It is recommended that persons who may have difficulty understanding or operating the shower controls should not be left unattended whilst showering. Special consideration should be given to young children and the less able bodied.

WARNING: After any servicing of the mains water supply, always ensure the unit is started on COLD in order to purge any air in the pipework.

OPERATING FUNCTIONS

Power on indicator (fig.35)

When the electricity supply to the shower is switched on at the isolating switch, the 'power' indicator will light.

Low pressure indicator (fig.35)

A red indication means the water pressure

has fallen below the minimum required for correct operation of the shower. In this state the low pressure cut-out has operated. This switches off power to the heating elements preventing undue temperature rises (water will continue to flow). Power will automatically be restored when adequate water pressure returns.

If the indication fluctuates between red and green, this means the pressure is only just sufficient and operating difficulties may be encountered.

A green indication shows that water pressure is sufficient for satisfactory operation of the shower.

Overheat cut-out

During normal operation if an overheat temperature is sensed, power to the elements will be reduced. Water will continue to flow. When the temperature has cooled sufficiently, power to the elements will be automatically restored to the previous setting at the time of interruption.

Safety cut-out

The unit is fitted with a non re-settable over-temperature safety device. In the event of abnormal operation which could cause unsafe temperatures within the unit, the device will disconnect the heating elements. It will require a visit from a qualified engineer to determine the nature of the fault and replace the safety device, once the unit has been repaired.

ADJUSTING THE SPRAYHEAD

Three sprayhead patterns are available (fig.36). Adjustment is by turning the bezel on the sprayhead in either direction until the desired pattern is obtained.

Maxi: A full spray perfect for a relaxing shower.

Ultra: A focused spray for a refreshing, satisfying shower.

Needle: A tingling, fine spray for a highly invigorating shower.

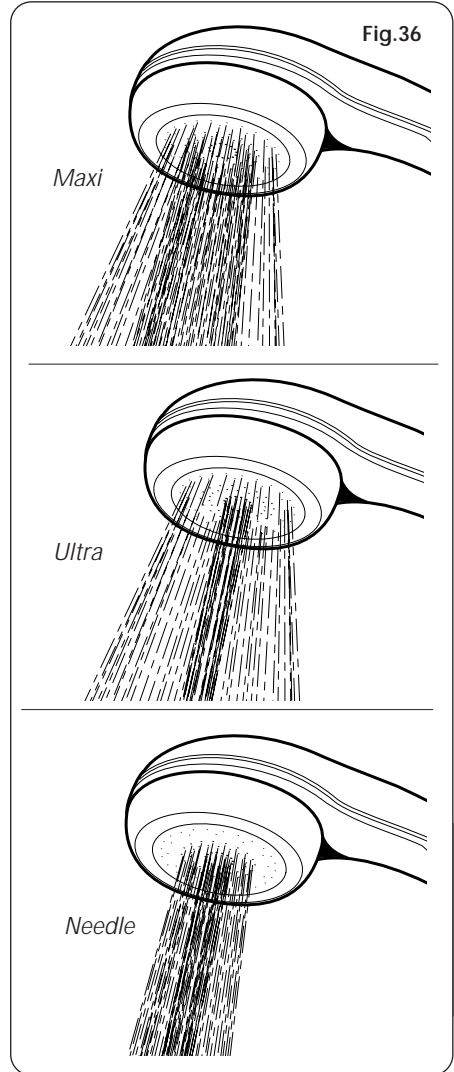

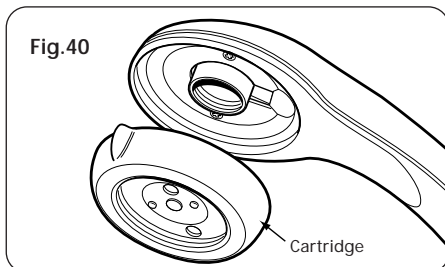
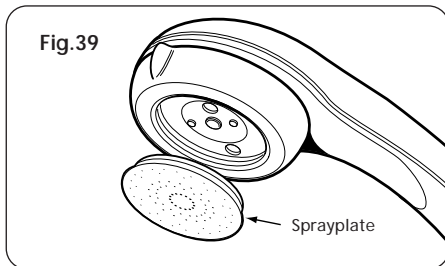
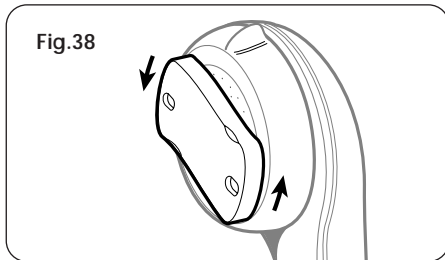
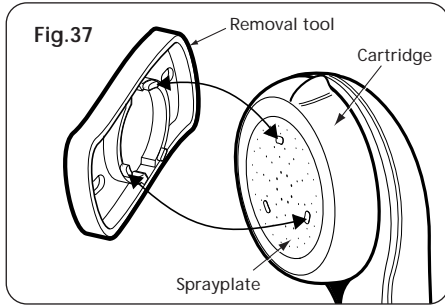

WARNING

Do not use 'powerful' abrasive or solvent cleaning fluids when cleaning the shower as they may damage the plastic fittings

USER MAINTENANCE

It is recommended that the shower unit, riser rail, hose etc. be cleaned using a soft cloth and that the use of abrasive or solvent cleaning fluids be avoided.

It is advised before cleaning, that the isolation switch be turned off, thus avoiding accidental switching on of the shower. IT IS MOST IMPORTANT TO KEEP THE SPRAYHEAD CLEAN IN ORDER TO MAINTAIN THE PERFORMANCE OF THE SHOWER. The hardness of the water will determine the frequency of cleaning.

Sprayplate and cartridge removal

There is no need to remove the sprayhead from the hose.

Using the removal tool supplied (fig.37), locate the three raised 'bosses' into the three recesses in the sprayplate. Hold in firmly and twist anti-clockwise (fig.38). This movement may turn the cartridge assembly as well until it reaches a 'stop'. Hold the cartridge firmly and continue to twist anti-clockwise. Having loosened the sprayplate sufficiently, it can be unscrewed and removed completely (fig.39). To remove the cartridge, hold firmly and turn anti-clockwise until it unscrews from the sprayhead (fig.40).

Clean the sprayplate and cartridge with a suitable brush or preferably leave them to soak overnight in a mild proprietary descaler. Ensure all traces of scale are removed and thoroughly rinse in clean water afterwards.

Before replacing the sprayplate and cartridge, switch the power back on at the isolating switch, direct the hose and sprayhead to waste, select the COLD setting, turn the temperature control fully anti-clockwise and press the start/stop button. This operation will flush out any loose scale deposits in the unit. Stop after approximately 30 seconds.

Refit the sprayplate and cartridge by screwing both in clockwise. Use the tool to screw in the sprayplate tight.

FAULT FINDING

Problem/Symptom	Cause	Action/Cure
1 Shower inoperable, no water flow.	1.1 Interrupted power supply.	1.1.1 Blown fuse or circuit breaker. Check supply. Renew or reset fuse or circuit breaker. If it fails again, consult a qualified electrician. 1.1.2 Power cut. Check other appliances and if necessary, contact local Electricity Supply Co.
	1.2 Unit malfunction.	1.2.1 Have unit checked. Ring Customer Service.
2 Water too hot.	2.1 Not enough water flowing through the shower.	2.1.1 Increase flow rate via temperature control. 2.1.2 Blocked sprayhead - clean or replace blocked sprayplate in sprayhead.
	2.2 Blockage in supply.	2.2.1 Check if stop valves are fully open. Check if blockage in inlet filter.
	2.3 Increase in ambient water temperature.	2.3.1 Re-adjust flow rate to give increased flow. 2.3.2 Select 'economy' power.
3 Water temperature cycling hot/cool at intervals.	3.1 Heater cycling on outlet thermal cut- out.	3.1.1 See ' <i>Water too hot</i> ' causes 2.1, 2.2 and 2.3 and their appropriate action/cures. If it continues, contact Triton Customer Service.
4 Water too cool or cold.	4.1 Too much flow.	4.1.1 Reduce flow rate via temperature control.
	4.2 Water pressure below minimum required (see rating label).	4.2.1 Is water supply mains or tank fed ?
		4.2.2 If tank fed, re-plumb to mains water supply or see 4.2.4.
		4.2.3 If mains fed, ensure that mains stopvalve is fully open and that there are no other restrictions in the supply while shower is in use, or see 4.2.4.
4.2.4 Fit pump to give minimum pressure (see rating label). Contact Customer Service for advice.		
4.3 Reduction in ambient water temperature.	4.3.1 Re-adjust flow rate to give reduced flow. 4.3.2 Select 'high' power.	
4.4 Electrical malfunction.	4.4.1 Have unit checked by suitably qualified electrician or contact Triton Customer Service.	
5 Shower varies from normal temperature to cold during use.	5.1 Water pressure has dropped below minimum required.	5.1.1 Wait until the water pressure resumes to normal.
6 Pressure relief device has operated (water ejected from PRD tube). Note:- Identify cause of operation before fitting new PRD unit. When fitting a new PRD, follow the commissioning procedure.	6.1 Blocked sprayhead.	6.1.1 Clean or replace blocked sprayplate in sprayhead and then fit new PRD.
	6.2 Twisted/blocked flexible shower hose.	6.2.1 Check for free passage through hose. Replace the hose if necessary and fit new PRD.
	6.3 Sprayhead not removed whilst commissioning.	6.3.1 Fit new PRD. Commission unit with sprayhead removed.

It is advised all electrical maintenance/repairs to the shower be carried out by a suitably qualified person.

Ref.	Description	Part No.																					
8	Can assembly 7.5kW Can assembly 8.5kW Can assembly 9.5kW	83305450 83305460 83305470																					
9	Terminal block	22007020																					
10	Switching module assy. c/w actuator & m'switches	82500160																					
11	Solenoid valve assembly (Eaton)	22007740																					
12	Thermal cut-out (main)	22008310																					
13	Pressure Relief Device	82800450	14	Stabiliser valve assembly	82600550	15	Start/stop switch assembly	83305380	16	Outlet pipe assembly c/w wires & PRD	85000160	17	Insert trim - cover	7052245	18	Insert trim - backplate	7052244	-	Power neon	82300520	-	Microswitch and wire kit	83305390
14	Stabiliser valve assembly	82600550																					
15	Start/stop switch assembly	83305380																					
16	Outlet pipe assembly c/w wires & PRD	85000160																					
17	Insert trim - cover	7052245																					
18	Insert trim - backplate	7052244																					
-	Power neon	82300520																					
-	Microswitch and wire kit	83305390																					

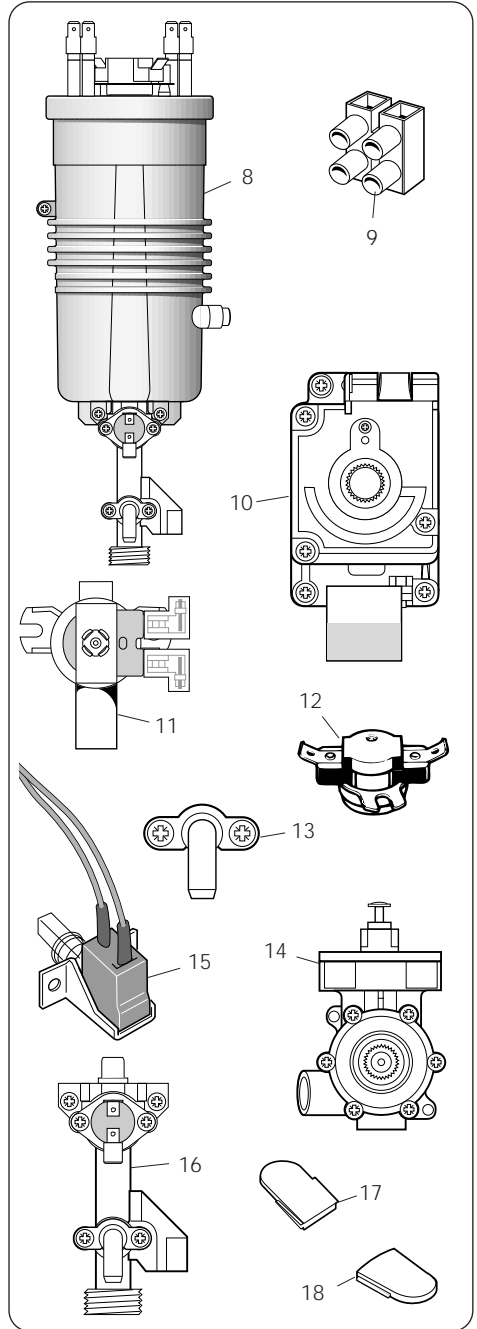

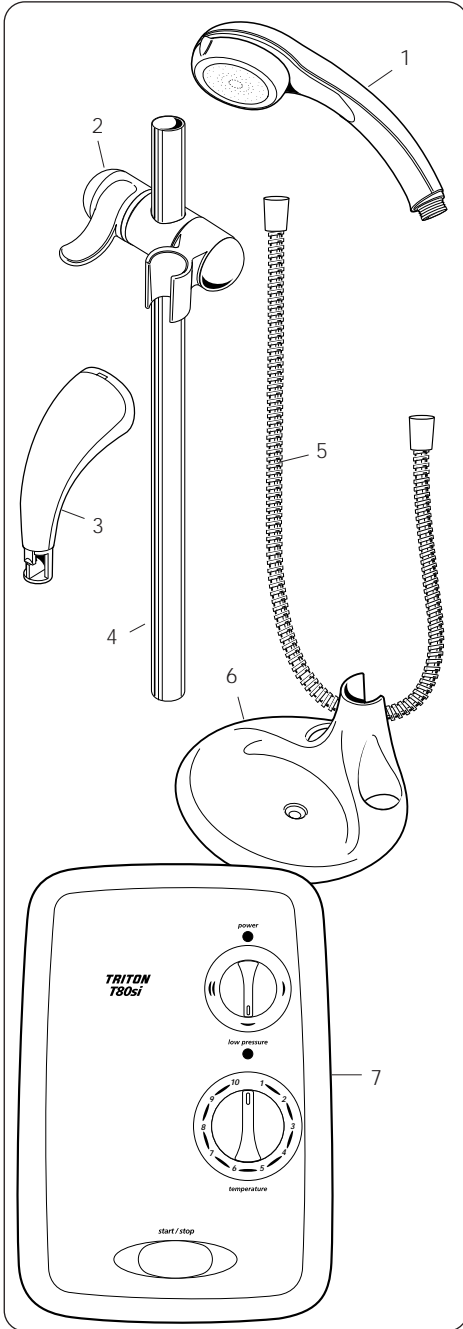

Ref.	Description	Part No.
1	3 mode sprayhead	22008290
2	Sprayhead holder	83306190
3	Brackets (pr.)	83306160
4	Riser rail	7042409
5	Flexible hose chrome	22007500
6	Soap dish white	22008960
7	Cover assembly c/w knobs & button	84900010

VOLTAGE AND AMPERAGE REFERENCE

The electrical rating of the shower is shown on the rating label within the unit (see electrical connections).

The table below can be used to ascertain amperage given the unit voltage.

NOTE: The elements on UK models are to 240V specification and will give a lower kW rating if the voltage supply is below 240V.

It is important to ensure that the supply voltage is the same as that shown on the rating label inside the unit. If not, then these tables will become invalid.

Important: All wiring **MUST** conform to local regulations. If in any doubt always consult a qualified electrician.

Amperage chart (UK and export models)										
Unit voltage	Rating (kW)									
	3	4	5	6	7	7.5	8	8.5	9.5	10
240	12.5	16.6	20.8	25.0	29.2	31.2	33.3	35.4	39.6	41.7
230	13.0	17.4	21.7	26.1	30.4	32.6	34.8	36.9	41.3	43.5
220	13.6	18.2	22.7	27.3	31.8	34.0	36.6	38.6	43.0	45.5
210	14.3	19.0	23.8	28.6	33.3	35.7	38.0	40.4	45.2	47.6

Cable sizes	
Amperes	Cable size (mm ²)
Up to 13	1.5
13 - 20	2.5
20 - 26	4.0
26 - 52	6.0 - 10.0



*A **MORGROS** Company*

TRITON STANDARD GUARANTEE

Triton Plc guarantee this product against all mechanical and electrical defects arising from faulty workmanship or materials for a period of two years for domestic use only, from the date of purchase, provided that it has been installed by a competent person in full accordance with the fitting instructions.

Any part found to be defective during this guarantee period we undertake to repair or replace at our option without charge so long as it has been properly maintained and operated in accordance with the operating instructions, and has not been subject to misuse or damage.

This product must not be taken apart, modified or repaired except by a person authorised by Triton Plc. This guarantee applies only to products installed within the United Kingdom and does not apply to products used commercially.

This guarantee does not affect your statutory rights.

What is not covered:

1 Breakdown due to: a) use other than domestic

use; b) wilful act or neglect; c) any malfunction resulting from the incorrect use or quality of electricity, gas or water or incorrect setting of controls; d) faulty installation.

2 Repair costs for damage caused by foreign objects or substances.

3 Call out charges where no fault has been found with the appliance.

4 The cost of repair or replacement of pressure relief devices, sprayheads, hoses, riser rails and/or wall brackets, isolating switches, electrical cable, fuses and/or circuit breakers or any other accessories installed at the same time as these do not form the mechanical and electrical components contained within the unit..

5 The cost of routine maintenance, adjustments, overhaul modifications or loss or damage arising therefrom, including the cost of repairing damage, breakdown, malfunction caused by corrosion, furring, pipe scaling, lime scale, system debris or frost.

Service Policy

In the event of a complaint occurring, the following procedure should be followed:

1 Telephone Customer Service on 024 7637 2222 (0345 626591 in Scotland and in Northern Ireland), having available the model number and power rating of the product, together with the date of purchase.

2 Triton Customer Service will be able to confirm whether the fault can be rectified by either the provision of a replacement part or a site visit from a qualified Triton service engineer.

3 If a service call is required it will be booked and the date of call confirmed. In order to expedite your request, please have your postcode available when booking a service call.

4 It is essential that you or an appointed representative (who must be a person of 18 years of age or more) is present during the service engineer's visit and receipt of purchase is shown.

5 A charge will be made in the event of an aborted service call by you but not by us, or where a call under the terms of guarantee has been booked and the failure is not product related (i.e. scaling and furring, incorrect water pressure, pressure relief device operation, electrical installation faults).

6 If the product is no longer covered by the guarantee, a charge will be made for the site visit and for any parts supplied.

7 Service charges are based on the account being settled when work is complete, the engineer will then request payment for the invoice. If this is not made to the service engineer or settled within 10 working days, a £10 administration charge will be added.

Replacement Parts Policy

Availability: It is the policy of Triton to maintain availability of parts for the current range of products for supply after the guarantee has expired. Stocks of spare parts will be maintained for the duration of the products' manufacture and for a period of five years thereafter.

In the event of a spare part not being available a substitute part will be supplied.

Payment: The following payment methods can be used to obtain spare parts:

1 By post, pre-payment of pro forma invoice by cheque or money order.

2 By telephone, quoting credit card (MasterCard or Visa) details.

Triton Plc, Shepperton Park, Caldwell Road,
Nuneaton, Warwickshire. CV11 4NR

Customer Service

 024 7637 2222

Scottish and Northern Ireland

Customer Service

 0345 626591

Installer Hotline

 024 7632 5491

Fax: 024 7632 4564