

unichrome

TRITON

NENE

Basin & bath taps

Installation Instructions

INSTALLERS PLEASE NOTE THESE INSTRUCTIONS ARE TO BE LEFT WITH THE USER

2180415B October 2005

INTRODUCTION

This guide contains all the necessary fitting instructions for your Unichrome basin and bath taps.

Please read this guide carefully before beginning your installation.

The tap installation must be carried out by a suitably competent person and in the sequence of the instruction book.

Care taken during the installation will provide a long life and trouble free operation from your taps.

These taps are suitable for all equal water pressures and should be fitted in accordance with Water Regulations.

DO NOT choose a position where the tap could become frozen.

Replacement parts can be ordered from Triton Customer Service (*see back page*).

COMPONENTS

The tap set comprises of the following:

Tap (2 off)

Sealing washer (2 off)

Lock nuts (2 off)

Check that all parts are correct.

INSTALLATION

Fit the taps into the basin, sink or bath as shown in **(fig.1)**.

Connect the hot and cold supplies to the taps using standard BSP tap connectors ($\frac{1}{2}$ " connectors for basin taps, $\frac{3}{4}$ " connectors for bath taps).

LEAK TESTING

Switch on the supplies — mains or gravity. Turn the tap on and test for leaks in the connections. Remedy if required.

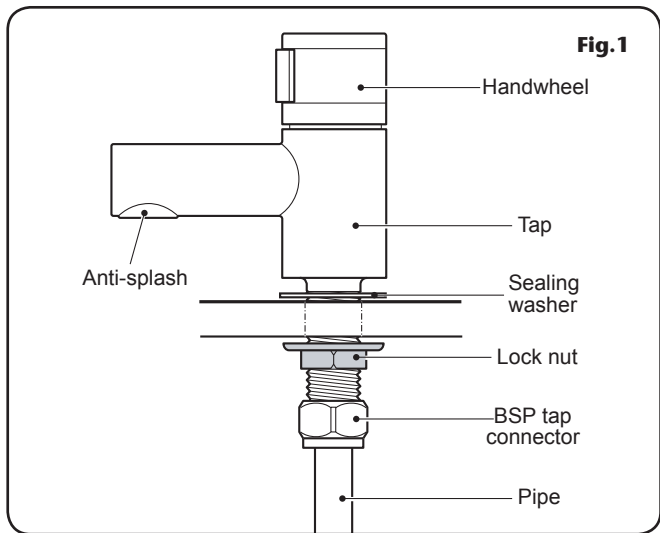

CLEANING

DO NOT use abrasive or solvent cleaning fluids. The taps should be cleaned using a soft cloth and warm water. Any stains should be removed using washing up liquid.

SPARE PARTS

Description

Part No.

1/4" turn ceramic valve (1/2")	83308060
1/4" turn ceramic valve (3/4")	83308080
Complete handwheel (basin)	83308200
Complete handwheel (bath)	83308210
Complete anti-splash	83308070

TRITON STANDARD GUARANTEE

Triton Plc guarantee this product against all mechanical defects arising from faulty workmanship or materials for a period of five years for domestic use only, from the date of purchase, provided that it has been installed by a competent person in full accordance with the installation and operating instructions.

Any part found to be defective during this guarantee period we undertake to repair or replace at our option without charge so long as it has been properly maintained and operated in accordance with the operating instructions, and has not been subject to misuse or damage.

This product must not be taken apart, modified or repaired except by a person authorised by Triton Plc. This guarantee applies only to products installed within the United Kingdom and does not apply to products used commercially.

This guarantee does not affect your statutory rights.

What is not covered:

- 1** Breakdown due to: *a)* use other than domestic use by you or your resident family; *b)* wilful act or neglect; *c)* any malfunction resulting from the incorrect use or quality of gas or water or incorrect setting of controls; *d)* faulty installation.
- 2** Repair costs for damage caused by foreign objects or substances.
- 3** Total loss of the product due to non-availability of parts.
- 4** Compensation for loss of use of the product or consequential loss of any kind.
- 5** Call out charges where no fault has been found with the unit.
- 6** The cost of routine maintenance, adjustments, overhauling modifications or loss or damage arising therefrom, including the cost of repairing damage, breakdown, malfunction caused by corrosion, furring, pipe scaling, limescale, system debris or frost.

Replacement Parts Policy

Availability: It is policy to maintain availability of parts for the current range of products for supply after the guarantee has expired. Stocks of spare parts will be maintained for the duration of the products' manufacture and for a period of five years thereafter.

In the event of a spare part not being available a substitute part will be supplied.

Payment: The following payment methods can be used to obtain spare parts:

- 1** By post, pre-payment of pro forma invoice by cheque or money order.
- 2** By telephone, quoting credit card (MasterCard or Visa) details.
- 3** By website order,
www.tritonshowers.co.uk

To use your Triton Guarantee please contact Unichrome Customer Service on +44 (0) 87 0067 8678 (Scotland +44 (0) 84 5762 6591).

Please have your postcode and model details available when you call.

Please note: Telephone calls may be recorded for training purposes.

Unichrome Customer Service

☎ +44 (0) 87 0067 8678

Scottish and Northern Ireland Customer Service

☎ +44 (0) 84 5762 6591

Trade Installer Hotline

☎ +44 (0) 24 7632 5491

Fax: +44 (0) 24 7632 4564

www.tritonshowers.co.uk

E mail: technical@triton.plc.uk