

**TRITON**

**T22i  
Shower pump**

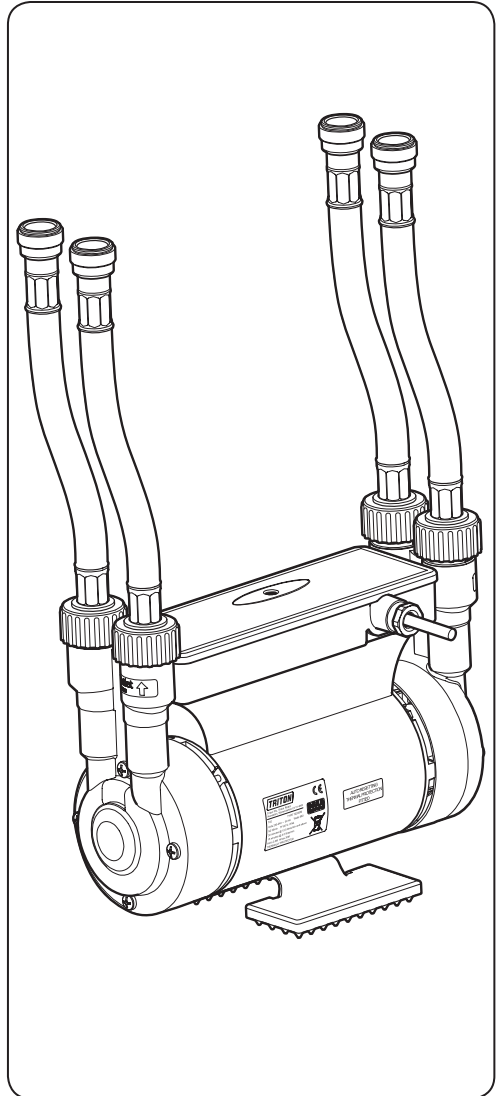

**Installation and  
operating  
instructions**

INSTALLERS PLEASE NOTE THESE INSTRUCTIONS ARE TO BE LEFT WITH THE USER

<b>CONTENTS</b>	<b>Page</b>
Plumbing and electrical notes	1
Introduction	2
Safety warnings	2
Key to main components	3
Water requirements	4
Electrical requirements	5
Siting of the pump	6
Installation	7
Commissioning	8
Spare parts	9
Fault finding	10
Guarantee, Service Policy, Etc.	Rear cover

### IMPORTANT SAFETY INFORMATION

#### 1 Plumbing

- 1.1 All installations must comply with Water Regulations/Bylaws.
- 1.2 DO NOT connect the pump unit to the mains water supply.
- 1.3 Supply pipes must be flushed thoroughly to clear debris and flux before connecting to the pump and shower.
- 1.4 DO NOT use excessive force when making connections to the flexible connector hoses.
- 1.5 DO NOT turn on the electrical supply to the pump until the plumbing connections and commissioning procedure have been completed. **The pump MUST NOT be operated dry without water.**
- 1.6 DO NOT solder pipes or fittings within 300mm of the pump, as heat transfer can damage the components.
- 1.7 The pump must be connected to dedicated water supplies. DO NOT fit the pump to a common supply.
- 1.8 The dedicated cold water supply must be taken directly from the cold water cistern to the pump. This draw-off must be on the opposite side of the cistern to the float operated valve. This also helps to prevent nuisance tripping of the pump.
- 1.9 The action of the pump is to increase the flow rate. If the supply pipe work cannot handle the resulting flow rate then:
  - 1.9.1 The anticipated flow rate may not be achieved.
  - 1.9.2 Air may be drawn into the hot supply from the vent pipe causing spluttering and temperature fluctuations at the showerhead.
- 1.10 A high level hot feed pipe must not rise above the level of the water in the cistern. To reduce the risk of air locks pipes should be run level with or below the base of the cistern.
- 1.11 Pipe runs must be as short as possible and standard full flow isolating gate valves or lever valves MUST be fitted to both inlet and outlet sides of the pump as an independent means of isolating the water should maintenance or servicing be necessary.
- 1.12 DO NOT use jointing compound on any pipe

fittings, use only the flexible hoses supplied to connect to the pump.

- 1.13 It is strongly recommended that copper pipe is used for the installation to avoid nuisance tripping of the pump.

#### 2 Electrical

- 2.1 The installation must be undertaken by a suitably competent person and comply with BS7671 "Requirements for electrical installations" (IEE wiring regulations) and building regulations. Make sure the hot and cold water connections to the pump are adequately bonded.
- 2.2 DO NOT turn on the electrical supply to the pump until the plumbing connections have been completed. **The pump MUST NOT be operated dry without water.**
- 2.3 The mains supply must be 230V 50Hz, connected to the pump via a double pole switched connection unit fused at 5 Amps, having a contact separation of at least 3mm in all poles.
- 2.4 In accordance with "The Plugs and Sockets etc. (Safety) Regulations 1994", the pump is intended to be permanently connected to the fixed electrical wiring of the mains system.
- 2.5 To enhance electrical safety a 30mA residual current device (RCD), also known as a residual current circuit breaker (RCCB), should be installed in the supply circuit. This may be part of the consumer unit or a separate unit.
- 2.6 The wires in the supply cable are coloured in accordance with the following code:
 

Brown	—	Live <b>L</b>
Blue	—	Neutral <b>N</b>
Green/Yellow	—	Earth <b>E</b>

The supply cable can only be replaced by the manufacturer or an authorised agent.
- 2.7 Always disconnect the supply before any form of work or maintenance on the pump.

Due to continuous improvement and updating, specification may be altered without prior notice.

Replacement parts can be ordered from Triton Customer Service. See 'spare parts' for details.

### INTRODUCTION

This book contains all the necessary fitting and operating instructions for your Triton power shower pump. Please read them carefully.

Care taken during the installation will provide a long and trouble free life from your unit.

**IMPORTANT:** All plumbing connections MUST be completed before making the electrical connections.

Please read through the whole of this book before beginning your installation.

### SPECIFICATION

#### DUTY CYCLE

30 minutes on @ 12.5 litres/min —  
120 minutes off.

15 minutes on @ 4 litres/min —  
120 minutes off.

#### REQUIRED PRESSURES

Maximum pump working head ( $H_{max}$ ) is  
30 metres.

Minimum static head is 1 metre.

### SAFETY WARNINGS

**In the interest of electrical safety a 30mA residual current device (RCD) should be installed in all UK electric and pumped shower circuits. This may be part of the consumer unit or a separate unit.**

- a.** Under no circumstances must this pump be connected to a mains cold water supply. Failure to comply will invalidate the guarantee.
- b.** The shower pump MUST NOT be used if suspected of being frozen.
- c.** The pump MUST be earthed.
- d.** Switch off immediately at isolating switch if water ceases to flow during use.
- e.** DO NOT operate the unit outside the guidelines laid out in 'site requirements'.
- f.** This pump is to be used for providing water to a shower only.

#### Standards and approvals

Splashproof rating IPX4

Complies with the requirements of current British and European safety standards for household and similar electrical appliances.

Complies with requirements of the British Electrotechnical Approvals Board (BEAB).

Meets with Compliance with European Community Directives (CE).

Fig.1

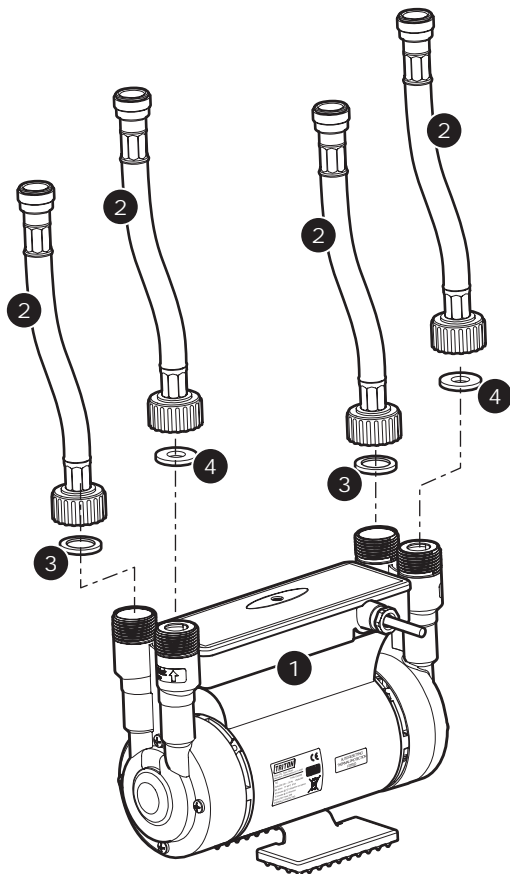

**KEY TO MAIN COMPONENTS (fig.1)**

- 1. Pump
- 2. Connector hose
- 3. Inlet filter washer
- 4. Rubber washer

## WATER REQUIREMENTS

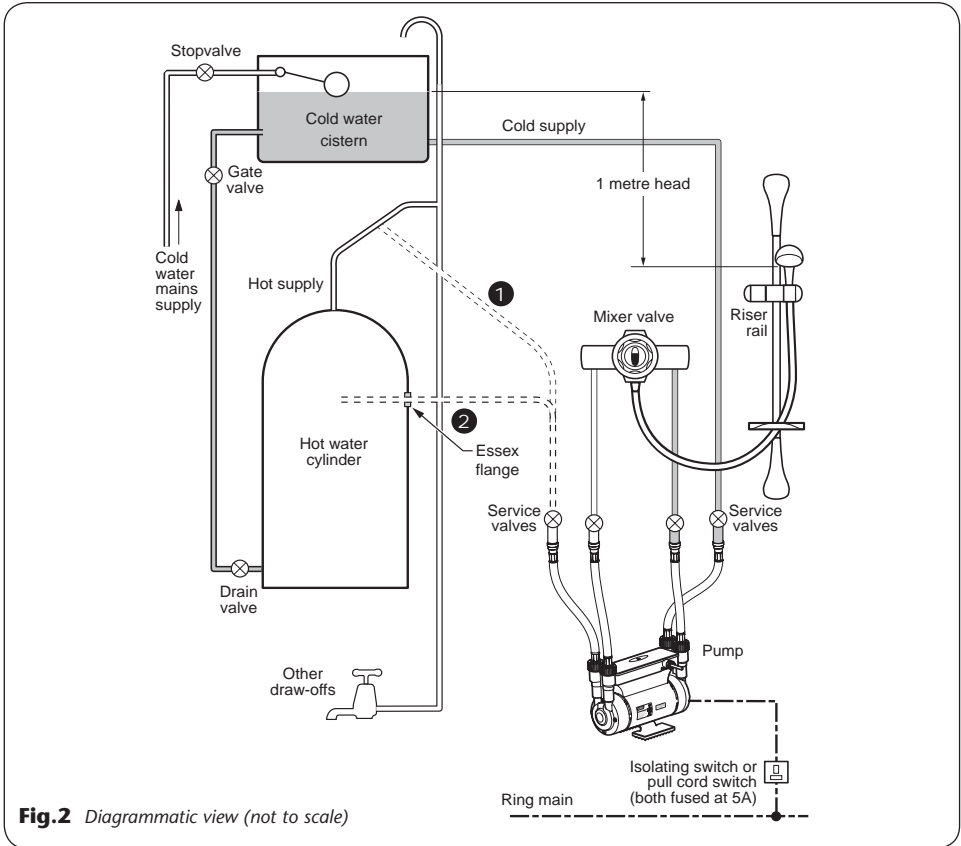

**Fig.2** Diagrammatic view (not to scale)

### WARNING!

**THIS PUMP IS DESIGNED TO SUPPLY WATER TO A SHOWER ONLY.**

The installation must be in accordance with Water Regulations and Bylaws.

For correct operation of this shower pump in addition to the shower unit, water must be gravity fed at nominally equal pressures directly from the same cold water storage cistern (the hot water being fed to the pump via the hot water storage cylinder). The hot water cylinder should have a minimum capacity of 136 litres

and the cold water cistern 225 litres.

It is advisable to check that the replenishment rate from the float operated valve meets the output requirements.

Both the hot and cold water supplies to the pump must be direct and not significantly affected by any other outlets or connections.

**Fig.2** shows the two recommended installation methods:

1. The connection can be taken via a tee connection on the underside of the rising angled section of pipe work from the cylinder.
2. The connection is taken directly from the hot water storage cylinder via a "No Stop Essex flange".

To comply with BS6700 the hot water storage temperature should not exceed 60°C. Operation at this temperature will also reduce the rate of formation of limescale in the system. The water supply must not exceed 65°C (149°F).

**THE PUMP MUST NOT BE CONNECTED TO THE MAINS COLD WATER SUPPLY.**

DO NOT connect into the rising vent pipework.

The pump must be positioned below the cold water cistern and not placed in areas where it will be subject to freezing conditions.

To guarantee correct operation of the flow switches, all pipe work must be below the cold water cistern and the showerhead must be at least 1 metre below the surface of the water in the cold water cistern.

In situations where this cannot be met, contact Triton Customer Service for advice. If used with a combination cylinder, the cold water cistern must have a capacity of at least 225 litres (50 gals) to avoid starvation of water to the pump, and a minimum head of water of 1 metre.

## **ELECTRICAL REQUIREMENTS**

### **WARNING! THE PUMP MUST BE EARTHED.**

The pump must be connected to a 230V 50Hz electrical supply, via a double pole switch having a contact separation of at least 3 mm in all poles. This can be a ceiling mounted pull cord switch in the shower room, or a wall mounted switch in a nearby room.

The pump installation must be fused at 5 amps.

A Residual Current Circuit Breaker (RCCB) also known as a Residual Current Device (RCD) having a tripping current not exceeding 30mA should be installed in the supply circuit. This may be part of the consumer unit or a separate unit.

**Note:** The installation MUST comply with current IEE regulations.

When installed in any room containing a fixed bath or shower, the pump MUST be located and concealed inside a suitable cupboard, built-in unit or other enclosure, so that the pump cannot be sprayed with water, and such that a person using a fixed bath or shower cannot access the pump without using tools.

### SITING OF THE PUMP

**WARNING!**  
**THE UNIT MUST NOT BE POSITIONED WHERE IT WILL BE SUBJECT TO FREEZING CONDITIONS.**

The pump MUST ALWAYS be positioned BELOW the cold water cistern and be situated as close as possible to the hot water cylinder. It is recommended that the cold water supply is taken from the opposite side of the cistern to the float operated valve to prevent air entrapment in the supply.

The pump should be located as close as possible to the water supplies to obtain maximum performance and positioned below the level of the mixing valve if possible.

Position the pump in a suitable area and make sure it is accessible for any maintenance etc. that may be necessary.

**IMPORTANT:** Make sure there is sufficient ventilation around the pump to cool the motor.

### INSTALLATION

**WARNING!**  
**Installation of the pump will break the earth continuity of the pipework installation. It is important that the earth be restored by cross bonding the pipework, to conform with current IEE regulations.**

Before installing the pump, make sure the site conditions have been complied with fully.

Also note the following:

- Pipework to precede wiring.
- Position the pump in a dry area, preferably in a linen/airing cupboard, where it must be well ventilated and not covered with towels and sheets, etc.
- DO NOT use with a combination cylinder system unless the cold water cistern has capacity of 225 litres (50 galls) or more.
- To assist in clearing air bubbles from the system avoid using sharp bends where possible. Flexible/swept fittings or formed pipework is recommended.
- Make sure that all water supplies are isolated before connection. Gate valves or full way lever valves must be fitted in the connections to the pump. It is also advisable to fit a drain off point on the lowest part of the system.
- NEVER use any form of soldered fittings on the shower pump as this will damage the unit and invalidate the guarantee.
- NEVER use solder within 300mm of the pump or expose parts to a hot torch.
- Make sure the mains electricity supply is SWITCHED OFF before making the electrical connections.
- DO NOT OPERATE THE PUMP DRY. This may cause damage to the seals and will invalidate the guarantee.

**Note:** The pump motor has automatically resetting thermal overload protection.



### Procedure

- a.** Turn off mains water and electrical supplies. Drain the cold water cistern and hot water cylinder and make a suitable connection to the hot water supply.
- b.** Position the pump horizontally (with the ports in the upright position) with the feet on a solid base so that it will not transmit vibration.

**Note:** The pump MUST ONLY be placed in the horizontal position.

- c.** Connect the inlet flexible connectors to the inlet ports of the pump ensuring the filters are in position on the inlets (**fig.3**).  
The hot and cold supplies can be connected to either end of the pump.
- d.** Connect the outlet flexible connectors to the outlet ports of the pump.
- e.** Connect the hot and cold feed pipes from the mixer valve to the outlet flexible push-in connectors.
- f.** At this stage, DO NOT connect the hot and cold water supplies from the cistern and cylinder to the inlet flexible push-in connectors. Wait until the commissioning procedure has been completed.

**Note:** DO NOT overtighten the connections on the pump ports and take care to prevent any system debris from entering the pump via the connectors.

### Electrical connections

**SWITCH OFF THE ELECTRICITY SUPPLY AT THE MAINS.**

Connect the pump via a double pole switch having a contact separation of at least 3mm in all poles with a 5 Amp fuse.

The wires in the supply cable are coloured in accordance with the following code:

Brown	—	Live <b>L</b>
Blue	—	Neutral <b>N</b>
Green/Yellow	—	Earth <b>E</b>

This can be a ceiling mounted pull cord switch in the shower room, or a wall mounted switch in a nearby room.

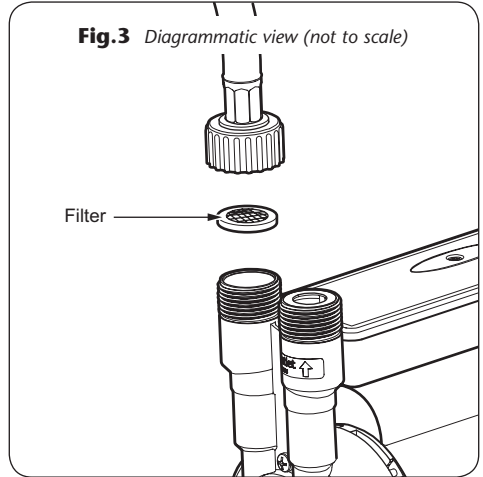

### COMMISSIONING

Before the first operation of the shower pump, it is necessary to flush out any system debris from the installation. This operation must be carried out with the pump isolated from the electricity supply, and with the pump feed pipework from the cistern and cylinder directed to waste by connecting a suitable length of hose.

#### Procedure

1. Make sure the isolating valves from the cistern and cylinder are closed.
2. Turn on the mains water supply to the storage cistern and allow the cylinder and system to fill.
3. Open both isolating valves and flush through thoroughly.
4. Allow water to flow to waste for two or three minutes to make sure any installation debris and air is completely flushed from the system.
5. Check the system pipework for leaks.
6. Close both isolating valves. Remove the waste hoses and connect the cistern supply pipework and cylinder pipework to the pump inlet flexible push-in connectors.
7. Remove the showerhead from the mixer valve hose and direct the hose to waste.
8. Open the mixer valve fully and then re-open both isolating valves.
9. Allow water to flow under gravity from the hose for a few minutes.
10. Stop the flow at the mixer valve.
11. Switch on the mains electricity supply to the shower pump.
12. Open the mixer valve. The pump will operate and water will flow. Allow water to flow to waste for two or three minutes.
13. Check system pipework again for leaks.
14. Turn off the mixer valve — the pump will switch off and the water will cease to flow. Replace the showerhead onto the shower hose.
15. Switch off the electric supply to the pump and eliminate any leaks.

**Note:** If care has been taken to prevent any obvious debris entering the system, the above procedure should be adequate for normal operating conditions of the pump and shower. However, it may be advisable to also clean the filters in the inlet ports of the pump as an extra precaution.

### CLEANING

Clean the unit with a damp cloth using clean water or mild liquid detergent.

**DO NOT use acid or abrasive detergents.**

**SPARE PARTS**

<b>Ref</b>	<b>Description</b>	<b>Part No.</b>
1.	Pump assembly	T22100M
2.	Hose assembly	83309460
3.	Filter/seal pack	83309470

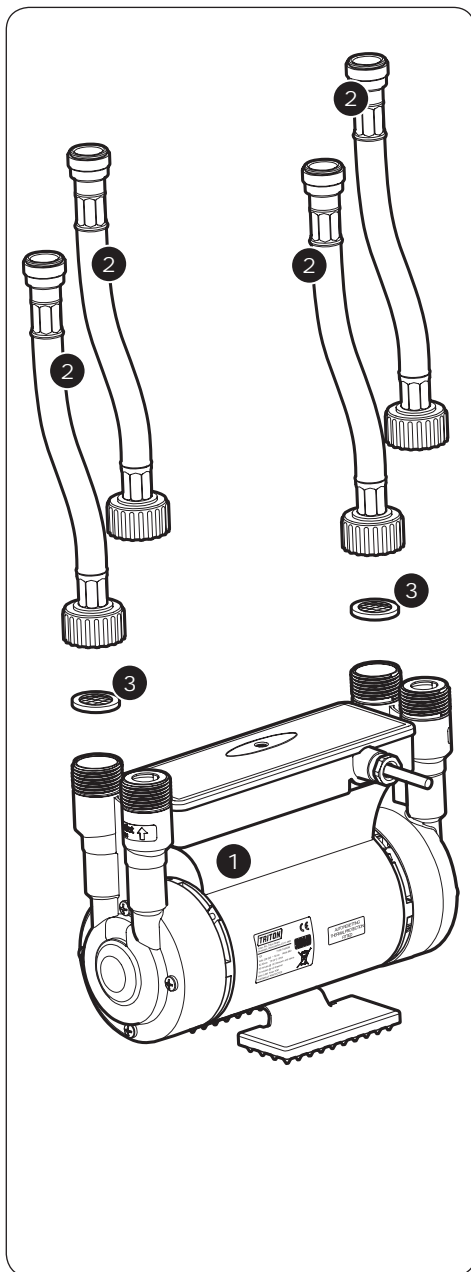

### FAULT FINDING

<b>Problem/Symptom</b>	<b>Cause</b>	<b>Action/Cure</b>
<b>1</b> Pump motor does not operate.	<p><b>1.1</b> Pump motor thermal overload protection activated.</p> <p><b>1.2</b> Mains electricity supply fault.</p> <p><b>1.3</b> Loose wiring connections.</p> <p><b>1.4</b> Insufficient flow to operate flow switch.</p> <p><b>1.5</b> Failed pump motor.</p>	<p><b>1.1.1</b> Allow the pump motor to cool and automatically reset.</p> <p><b>1.1.2</b> Check the pump is adequately ventilated.</p> <p><b>1.2.1</b> Blown fuse. Check supply, and renew or reset fuse. If it fails again, contact Customer Service.</p> <p><b>1.2.2</b> Power cut? Check other appliances and if necessary contact local Electricity Company.</p> <p><b>1.3.1</b> Check all connections and secure where necessary.</p> <p><b>1.4.1</b> Check isolating valve is fully open.</p> <p><b>1.4.2</b> Check head of water.</p> <p><b>1.4.3</b> Make sure the inlet filter is clean.</p> <p><b>1.5.1</b> Replace the pump unit. Contact Triton Customer Service.</p>
<b>2</b> Poor or no water flow.	<p><b>2.1</b> Pump motor not running.</p> <p><b>2.2</b> Pump or shower unit frozen.</p> <p><b>2.3</b> Water turned off.</p> <p><b>2.4</b> No water in cold storage cistern.</p> <p><b>2.5</b> System blockage.</p> <p><b>2.6</b> Blocked showerhead on shower unit.</p> <p><b>2.7</b> Blocked filter.</p>	<p><b>2.1.1</b> See causes 1.1, 1.2, 1.3, 1.4, 1.5, and 1.6.</p> <p><b>2.2.1</b> Check for evidence of freezing. Contact Triton Customer Service for advice.</p> <p><b>2.3.1</b> Check isolation valves and water supply.</p> <p><b>2.4.1</b> See 2.3.1.</p> <p><b>2.5.1</b> Isolate supplies and inspect inlet filter, pump outlet and showerhead.</p> <p><b>2.6.1</b> Clean the showerhead. Refer to separate instructions.</p> <p><b>2.7.1</b> Clean filter.</p>
<b>3</b> Pump does not switch off.	<b>3.1</b> Faulty flow switches.	<b>3.1.1</b> Isolate electric supply to pump. Contact Triton Customer Service for advice.

**Any maintenance or repair to the pump MUST be carried out by a suitably competent person.**





## RECYCLING REQUIREMENTS

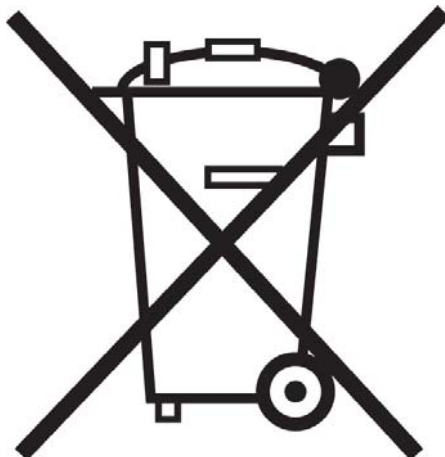

To ensure that local and national legislation is complied with, Triton plc ask that you dispose of any obsolete product in an environmentally friendly manner.

Do not place obsolete products in a wheelie bin.



*A **MORCROS** Company*

## Service Policy

In the event of a complaint occurring, the following procedure should be followed:

- 1** Telephone Customer Service on +44 (0) 87 0067 3333 (+44 (0) 84 5762 6591 in Scotland and in Northern Ireland), having available the model number and power rating of the product, together with the date of purchase.
- 2** Triton Customer Service will be able to confirm whether the fault can be rectified by either the provision of a replacement part or a site visit from a qualified Triton service engineer.
- 3** If a service call is required the unit must be fully installed for the call to be booked and the date confirmed. In order to speed up your request, please have your postcode available when booking a service call.
- 4** It is essential that you or an appointed representative (who must be a person of 18 years of age or more) is present during the service engineer's visit and receipt of purchase is shown.
- 5** A charge will be made in the event of an aborted service call by you but not by us, or where a call under the terms of guarantee has been booked and the failure is not product related (i.e. scaling and furring, incorrect water pressure, pressure relief device operation, electrical installation faults).
- 6** If the product is no longer covered by the guarantee, a charge will be made for the site visit and for any parts supplied.
- 7** Service charges are based on the account being settled when work is complete, the engineer will then request payment for the invoice. If this is not made to the service engineer or settled within ten working days, an administration charge will be added.

## Replacement Parts Policy

**Availability:** It is the policy of Triton to maintain availability of parts for the current range of products for supply after the guarantee has expired. Stocks of spare parts will be maintained for the duration of the product's manufacture and for a period of five years thereafter.

In the event of a spare part not being available a substitute part will be supplied.

**Payment:** The following payment methods can be used to obtain spare parts:

- 1** By post, pre-payment of pro forma invoice by cheque or money order.
- 2** By telephone, quoting credit card (MasterCard or Visa) details.
- 3** By website order, [www.tritonshowers.co.uk](http://www.tritonshowers.co.uk)

Triton Plc  
Triton Road  
Nuneaton  
Warwickshire CV11 4NR

## TRITON STANDARD GUARANTEE

Triton Plc guarantee this product against all mechanical and electrical defects arising from faulty workmanship or materials for a period of two years for domestic use only, from the date of purchase, provided that it has been installed by a competent person in full accordance with the fitting instructions.

Any part found to be defective during this guarantee period we undertake to repair or replace at our option without charge so long as it has been properly maintained and operated in accordance with the operating instructions, and has not been subject to misuse or damage.

This product must not be taken apart, modified or repaired except by a person authorised by Triton Plc. This guarantee applies only to products installed within the United Kingdom and does not apply to products used commercially. This guarantee does not affect your statutory rights.

### *What is not covered:*

- 1** Breakdown due to: *a)* use other than domestic use by you or your resident family; *b)* wilful act or neglect; *c)* any malfunction resulting from the incorrect use or quality of electricity, gas or water or incorrect setting of controls; *d)* faulty installation.
- 2** Repair costs for damage caused by foreign objects or substances.
- 3** Total loss of the product due to non-availability of parts.
- 4** Compensation for loss of use of the product or consequential loss of any kind.
- 5** Call out charges where no fault has been found with the appliance.
- 6** The cost of repair or replacement of pressure relief devices, showerheads, hoses, riser rails and/or wall brackets, isolating switches, electrical cable, fuses and/or circuit breakers or any other accessories installed at the same time.
- 7** The cost of routine maintenance, adjustments, overhaul modifications or loss or damage arising therefrom, including the cost of repairing damage, breakdown, malfunction caused by corrosion, furring, pipe scaling, limescale, system debris or frost.

**Customer Service:** ☎ +44 (0) 87 0067 3333

**Scottish and Northern Ireland**

**Customer Service:** ☎ +44 (0) 84 5762 6591

**Trade Installer Hotline:** ☎ +44 (0) 87 0067 3767

**Fax:** +44 (0) 87 0067 3334

[www.tritonshowers.co.uk](http://www.tritonshowers.co.uk)

**E mail:** [technical@triton.plc.uk](mailto:technical@triton.plc.uk)