

Instructions For Fitting VARILIGHT 1–10V Dimmerswitches For 1 or Multiple Dimmable Ballasts

Thank you for choosing a VARILIGHT dimmerswitch. This dimmerswitch is designed for high frequency dimmable ballasts that require a 0–10V or 1–10V control signal.

This dimmerswitch is designed to work with one or multiple dimmable ballasts up to 10mA.

Do not use this dimmerswitch for any other purpose. The dimmerswitch will be damaged if used for these applications. **Do not connect the 1–10V control terminals to the mains.** Incorrect use will make your guarantee invalid.

Loading Your Dimmer Correctly

The mains switch is rated at 250V a.c. 10A maximum.

For optimal performance the total current from the 1–10V control signal should not be more than 0.5mA. Consult the specification for your ballast.

Fitting Your Dimmerswitch

Read the instructions below carefully. Incorrect installation may damage the dimmer beyond repair. **In case of any doubt or difficulty consult a qualified electrician.**

1. Switch off at the mains, then remove the existing switch and disconnect the wiring from the switch terminals at the rear, taking note of the present wiring of the switch and the marking on the terminals. Where there are two or more wires together in the old switch, they must be kept together in the dimmerswitch.
2. Most models can be fitted into a box with a minimum depth of 16mm (25mm for low profile or flat face plates), i.e. a normal plaster depth flush box or a normal surface mounted switch box. A box having 4 fixing lugs cannot be used without modifying it. The top and bottom lugs must be broken off or bent flat.
3. To connect the wiring for 1-way circuits or for 2-way circuits refer to the diagrams overleaf under the heading "Typical Lighting Circuits". If you are using a dimmerswitch in a 2-way circuit then you can only use one dimmerswitch in the circuit (an ordinary switch must be at the other end) and that dimmerswitch must be a push-on/push-off model. Take care that no bare wires project out of the terminals. Keep wires together in a terminal if they were together in your old switch.
4. Use screened 2-core cable for the 1–10V control signal. The outer (screening) conductor should be earthed at one end. **Do not connect the 1–10V control terminals to the mains.**
5. Dimmerswitches having a metal front plate must be earthed by means of the earthing point provided on the dimmer.
6. After connecting the wires screw the dimmerswitch gently into the wall box so that the front plate is not distorted or cracked. Do not trap the wiring between the rear of the dimmer and the back of the wall box.
7. Once installation is complete. Switch on the mains supply and switch on the dimmer, turning the control knob to give the desired light level.

GUARANTEE

In case of any defect, return the dimmer to our service department. Varilight undertakes to repair or replace, at its discretion, goods which have become defective within 12 months of purchase, solely as a result of faulty materials and workmanship, provided that:-

- a) The unit has been correctly fitted according to the instructions and has not been used with an incompatible load, fluorescent tubes, or overloaded beyond its rating, and has only been used on a 200-250V a.c. power supply.
- b) The dimmer module has not been tampered with or taken apart. However, for your convenience, it is perfectly in order to remove a faulty dimmer module from multi-gang dimmers by pulling off the knob and unscrewing the nut under the knob. You will then still have the remaining modules working whilst we service your faulty module.
- c) The unit is securely packed and safely returned to:-

Service Department, Caryl's Lea, Faygate, Horsham, West Sussex, RH12 4SJ (Tel. (01293) 851584) together with a letter stating the guarantee registration number below, the date and place of purchase, the type and wattage of the lighting or other load being controlled and the details of the fault.

This guarantee states Varilight's entire liability, which does not extend to cover consequential loss or damage or installation costs arising from a defective product. The guarantee does not apply to problems arising from any incompatibility between your lamps and the dimmer switch. This guarantee does not in any way affect the statutory rights of the purchaser and is offered so that you may have the benefit of our technical facilities.

GUARANTEE REGISTRATION NUMBER 121A

Typical Lighting Circuits

1-Way Circuits

In 1-way lighting circuits the ballast is controlled by one switch. Your dimmerswitch replaces this switch.

Your push-on/push-off dimmerswitch has the advantage that it can be switched on and off with a push action, while keeping the lighting at the level you have chosen.

Remove your old switch and copy the wiring configuration for the dimmerswitch. The wires from your old switch can be connected either way round to the "C" and "L1" terminals of the dimmerswitch. There is a spare terminal (L2) that you will not need to use for a 1-way circuit.

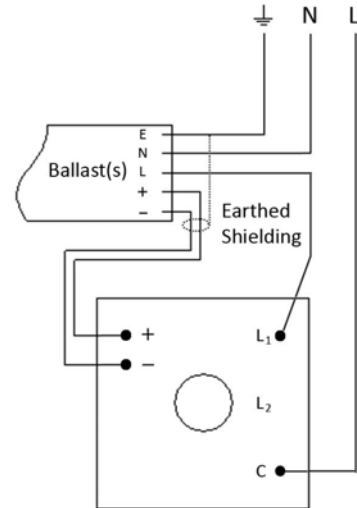

2-Way Circuits

2-way lighting circuits have two switches turning the same light or lights on and off from two different locations (e.g., at the top and bottom of the stairs). You must only replace **one** of these switches with a dimmerswitch or the lights will flicker. Two typical 2-way circuits are shown below.

Remove your old switch and copy the wiring configuration for your dimmerswitch. The wire(s) fitted in the "common" terminal of the old switch should be fitted into the "C" terminal of the dimmerswitch. The wires fitted into the other two terminals of the old switch should be fitted either way round into terminals "L1" and "L2" of the dimmerswitch.

Note: Dimmer switches have "C" next to "L1" & "L2" whereas most switches have "C" at the opposite end to "L1" & "L2".

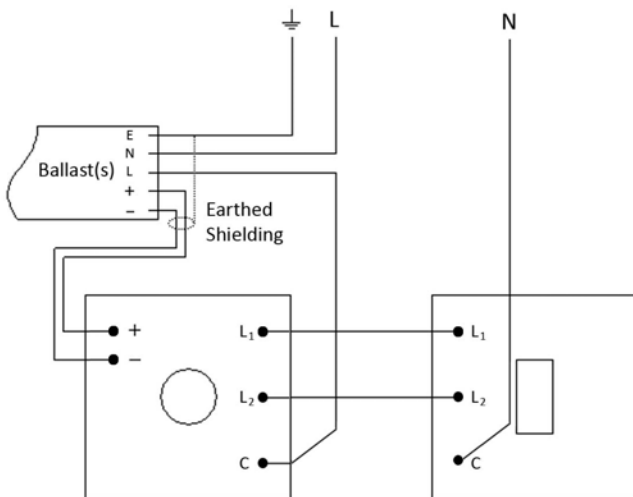

Dimmer must replace only one of the 2-way switches

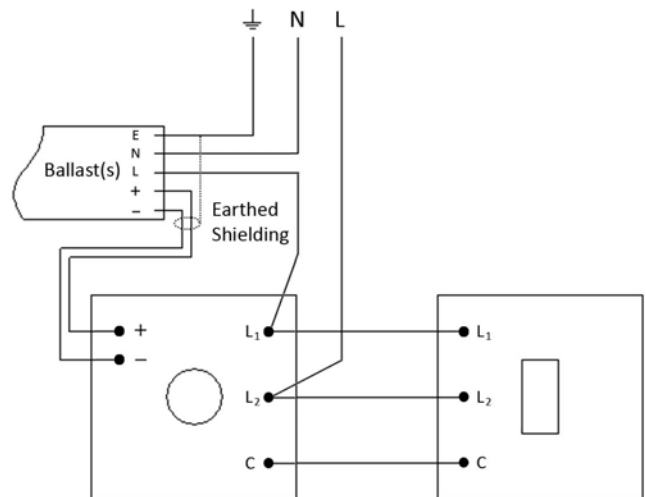

Dimmer must replace only one of the 2-way switches