

CLIP-1, 2, 3, 4

The Smallest Passive Infrared Detector Series



Installation Instructions

1. INTRODUCTION

The CLIP series features the smallest and most elegant PIR detectors presently marketed. The series includes four models that are slightly different in shape (Figure 1):

- **CLIP-1:** Wide Angle
- **CLIP-2:** Pet Alley
- **CLIP-3:** Long Range
- **CLIP-4:** Curtain

False alarms caused by environmental disturbances are virtually eliminated by a combination of a light rejection filter and a low-noise pyroelectric detector.

All four CLIP models are equipped with a two-step alternate polarity pulse counter for additional false-alarm protection. They provide reliable, long-life, trouble-free service.

Detailed specifications of the lenses employed in each model and mounting alternatives are given in Figures 2 through 9 below.

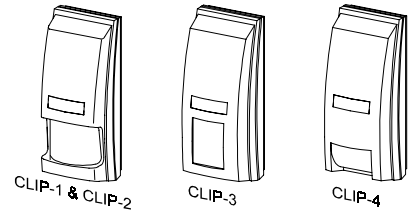
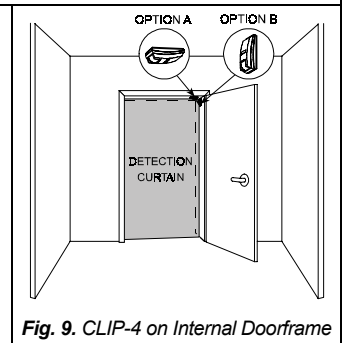
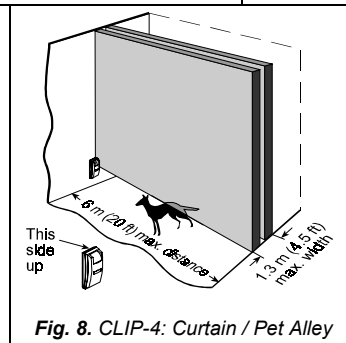
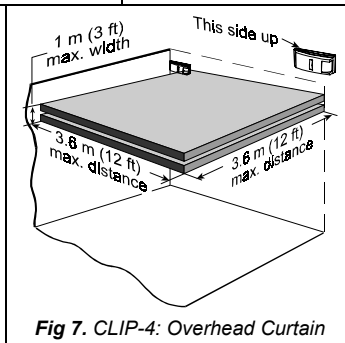
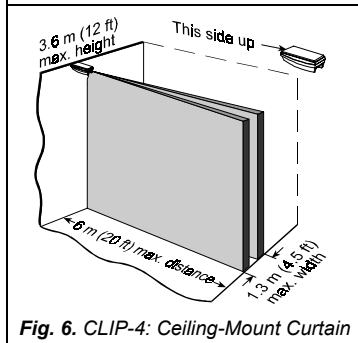
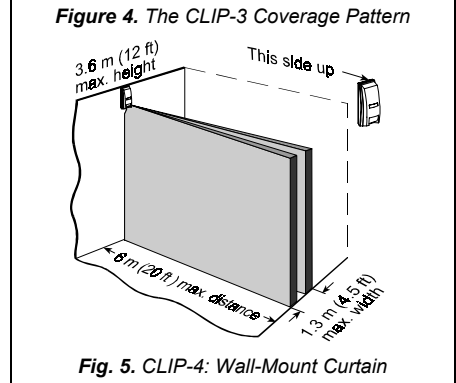
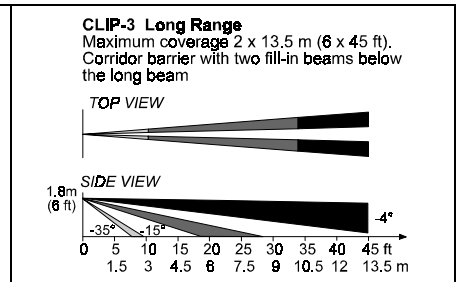
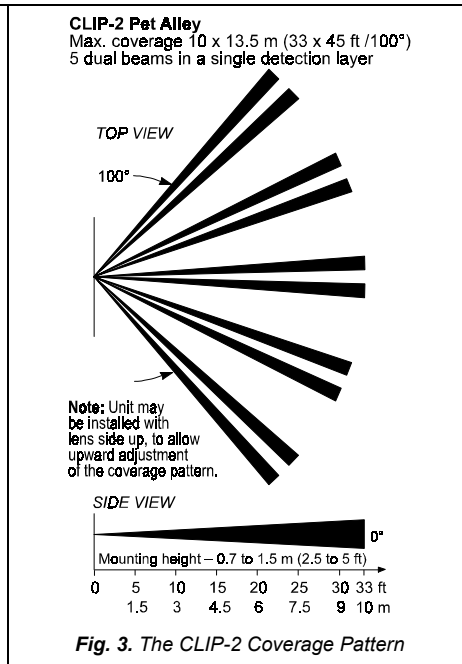
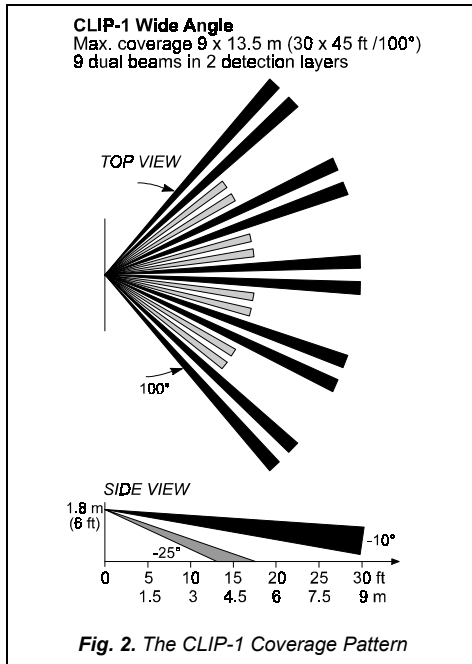

Fig. 1. The CLIP Models



2. SPECIFICATIONS

OPTICAL

Lens Characteristics: See Figures 2 through 9.

Adjustment: Vertical 0° to -12° calibrated scale.

ELECTRICAL

Voltage: 10 to 16 VDC.

Current Drain: 12.5 mA at 12 VDC.

Alarm Output: Normally closed (fail-safe) contacts. 18Ω resistor in series with contacts. Rating - 0.1A resistive / 30 VDC.

Tamper Output: N.C., rated at 50 mA resistive / 30 VDC.

Alarm Period: 2-5 seconds.

Pulse Counter: 2 position selector, 1 or 2 pulses (alternate polarity).

LED: Walk Test enabled or disabled with internal link.

Detector: Dual-element low noise pyroelectric sensor.

MOUNTING

CLIP-1, 2 and 3: Wall mounting.

CLIP-4: Wall or ceiling mounting.

Mounting Height: **CLIP-1 and 3** - Up to 2.4 m (8 ft); **CLIP-2:** 0.7 to 1.5 m (2.5 to 5 ft); **CLIP-4:** Up to 3.6 m (12 ft).

ENVIRONMENTAL

Operating Temperature: -10°C to 50°C (14°F to 122°F).

Storage Temperature: -20°C to 60°C (-4°F to 140°F).

RFI Protection: > 20 V/m to 1000 MHz.

PHYSICAL

Dimensions (H x W x D): 70 x 28 x 25 mm (2-3/4 x 1-1/4 x 1 in.).

Weight: 25 g (0.9 oz).

Color: White.

3. INSTALLATION

3.1 Disassembly and Assembly

A. Removing the Front Cover

Insert a small screwdriver into one of the narrow gaps at the sides of the name plate (see Fig. 10). Lever carefully sideways, until the name plate arches slightly out and snaps free (do not let it fly off). Retain the name plate and loosen the screw within the inner shaft (see Fig. 11). Remove the cover carefully, to avoid dropping the screw.

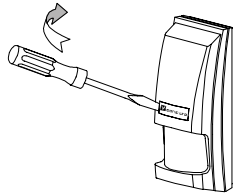

Fig. 10. Name-Plate Removal

B. Installing the Front Cover

Carefully fit the front cover onto the base, with the lens in front of the sensor, insert the screw into its shaft and tighten it well.

Position the name plate correctly, and insert one of the tabs into its groove. Press the free edge of the name plate sideways against the already seated edge, until the name plate arches slightly outward. Then force the other tab into its groove, and let the name plate snap into place.

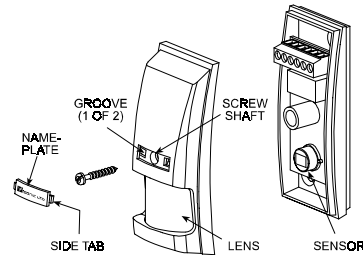

Fig. 11. Disassembly of the CLIP PIR

3.2 Mounting

The CLIP-1 through CLIP-3 are designed for surface mounting, and the regular position is with the lens down. The CLIP-4 may be mounted in various positions on walls, ceilings and door frames (see Figures 5 to 9).

CAUTION! To prevent false alarms caused by external temperature changes and sudden air gusts, CLIP detectors should not be mounted on or within window frames built into external walls. Moreover, it is mandatory to seal the wiring entry holes with sealing compound such as RTV, thus protecting the sensor from insects and air currents.

- Select the mounting location so that the expected motion of an intruder will cross the coverage pattern.
- The maximum mounting height for CLIP-1 and -3 is 2.4 m (8 ft).
- When mounting CLIP-4 on the ceiling (Figure 6), the ceiling height must not exceed 3.6 m (12 ft). The maximum detection distance is 6 m (20 ft), and the curtain width at that distance is 1.3 m (4.5 ft).
- Alternatively, the pet alley model CLIP-2 may be installed in a lens-up position. This will allow upward adjustment of the pet alley, so that the lower part of the detection pattern will be parallel to the floor.
- To minimize false alarms, it is advisable to avoid aiming the detector at heaters, sources of light, or windows subjected to direct sunlight. Also avoid running wiring close to high power electrical cables.
- Remove the front cover as instructed in Para. 3.1A.
- Mount the base with the PCB intact at the location and height that gives optimum coverage. Use the two mounting knockouts (see Fig. 12). Carefully slide the PCB up to gain access to the bottom knockout which is partly hidden.

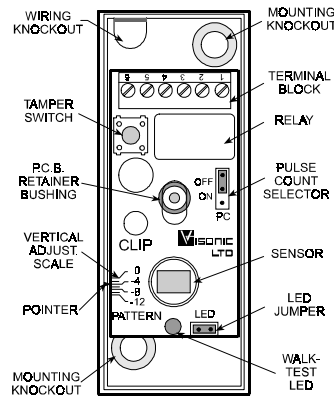

Fig. 12. Inside the CLIP

Be sure to do so by grabbing the terminal block with two fingers. Do not exert force on any other component!

- Always install the unit on a firm and stable surface, and assure that there are no moving objects within its field of view.

3.3 Wiring

To route wires into the detector, use the wiring knockout located at the top left of the unit base (Figure 12). Since the knockout is angular, the

wiring may be inserted from behind the base or from the top, as required for the particular installation. Refer to Fig. 13 and connect wires to the terminal block in the following order:

- Connect terminals 5 and 6 – the tamper N.C. terminals – to a normally closed 24-hour protective loop of the control panel. The tamper contacts will open when the cover is removed.
- Connect terminals 1 & 2 (the relay N.C. terminals) to a normally closed protective loop of the control panel. The relay contacts will open when motion is detected or during power loss.
- Connect terminals 3 (-) and 4 (+) to a 10 to 16 Volt DC power source (observe polarity). The power supply must have battery backup. The current drain of each CLIP PIR is approximately 12.5 mA.

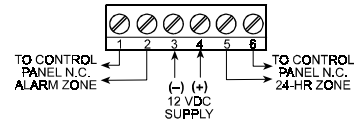

Fig. 13. Terminal Block Wiring

3.4 Vertical Adjustment

The vertical adjustment scale (on the lower left corner of the PCB) and the plastic pointer on the base indicate the approximate vertical angle between the horizontal line of the unit and the upper detection layer.

Table 1 shows the recommended scale settings for various combinations of mounting height and coverage distance. It allows fast, easy pattern adjustment from 0° to -12° according to the installation height and the required coverage range.

CLIP units are preset to -4°. To change the vertical pattern adjustment, remove the cover, hold the terminal block with two fingers and slide the PCB up or down to the desired angle.

Caution! CLIP is a delicate device due to its small size. Do not exert force on any component other than the terminal block.

The friction on the PCB should be enough to maintain the new position. When you remount the cover and tighten the screw, additional pressure is applied to the plastic bushing that binds the PCB to the back cover.

Note: Since the beam width increases with distance from the detector, an inverted (lens up) installation of the CLIP-2 (Pet Alley model) is advisable. Set the scale between -4° and -6°, to obtain the desired pet alley height.

Table 1. Vertical Adjusting Scale

Mounting Height	Coverage Range										
	7	10	13	17	20	23	26	30	36	45	
ft ⇒	7	10	13	17	20	23	26	30	36	45	
↓ m	2	3	4	5	6	7	8	9	11	13.5	
3	1	0°	0°	0°	0°	0°	0°	0°	0°	0°	
4	1.2	-8°	-6°	-4°	-4°	-2°	-2°	-2°	0°	0°	
5	1.5	-	-12°	-8°	-6°	-6°	-4°	-4°	-2°	-2°	
6	1.8	-	-	-12°	-10°	-10°	-8°	-6°	-6°	-4°	
7	2	-	-	-	-12°	-10°	-10°	-8°	-8°	-6°	
8	2.5	-	-	-	-	-12°	-10°	-10°	-8°	-8°	

Example: if you require a coverage range of 9 m (30 ft) and wish to install the sensor 1.8 m (6 ft) above the ground, set the Vertical Adjusting Scale to -6°.

3.5 The Pulse Counter

The CLIP is equipped with a pulse counter that can be set to count 1 or 2 pulses with alternate polarity, before activating the alarm relay. To set the pulse counter, place the jumper at the desired setting (ON or OFF).

ON (2 pulses). Provides improved protection against false alarms caused by all types of environmental disturbances. It should only be used in temperature controlled locations (less than 30°C / 86°F).

OFF (1 Pulse). Actually disables the pulse counter. Used to activate an alarm on the first detected pulse, or in high security installations, when fast "catch" performance is of greatest importance.

3.6 Walk Testing

- Apply 12 VDC and allow 5 minutes for warming up and stabilizing.
- Adjust the vertical calibration angle according to Table 1.
- Set the pulse counter per Para. 3.5 above.
- Walk slowly across the field of view (in opposite directions). The LED lights whenever you enter or exit a sensitive beam. Allow 5 seconds between each test for the unit to stabilize.
- After testing, you may disable the LED to prevent unauthorized persons from tracing the coverage pattern. Remove the LED jumper from its position across the 2 pins and install it on one of the pins.

Note: The range and coverage area should be checked at least once a year. To assure proper continuous functioning, the user should be instructed to perform a walk test at the far end of the coverage pattern to assure an alarm signal prior to each time the alarm system is armed.



VISONIC LTD (ISRAEL): P.O.B 22020 TEL-AVIV 61220 ISRAEL. PHONE: (972-3) 645-6789, FAX: (972-3) 645-6788
 VISONIC INC. (U.S.A.): 10 NORTHWOOD DRIVE, BLOOMFIELD CT. 06002-1911. PHONE: (860) 243-0833, (800) 223-0020 FAX: (860) 242-8094
 VISONIC LTD. (UK): FRASER ROAD, PRIORY BUSINESS PARK, BEDFORD MK44 3WH. PHONE: (0870) 7300800 FAX: (0870) 7300801
 INTERNET: www.visonic.com

©VISONIC LTD. 1998 CLIP D-1161-0 NEW: DE1161- (REV. 3, 12/98).

Refer to separate warranty statement

