

WT-201, WT-201WP

PENDANT TRANSMITTERS



Installation Instructions

1. INTRODUCTION

The WT-201 is a series of miniature transmitters, designed to send coded transmissions to wireless receivers of the WR-200 and WR-300 series. Transmission is activated by depressing the recessed pushbutton at the center of the unit. Transmitters with an A-suffix are equipped with a 4-channel selector. The WT-201WP is a waterproof version of the WT-201.

All WT-201 units are supplied with the chain installed, to be worn around the neck as a pendant transmitter. A key ring is also included in the package, for use in place of the chain. Operating power is obtained from a cylindrical 12-volt alkaline battery (Duracell MN-21, Golden Power GP-23A or equivalent).

A LED lights during transmission, indicating the battery voltage condition (lights when battery voltage exceeds 8 VDC). If the LED does not light during transmission, the battery must be replaced immediately.

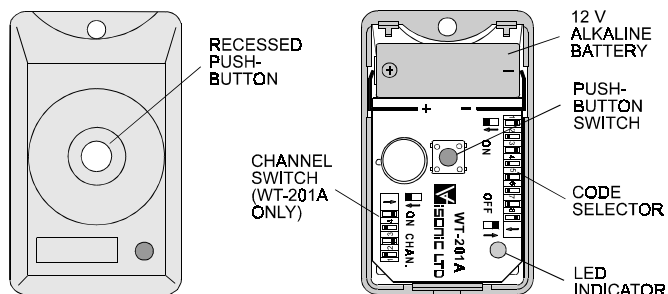

Figure 1. WT-201 with Cover Removed

2. SPECIFICATIONS

Frequency (MHz): 315, 304, 404, 418, 433.92 or other frequencies according to local requirements.

Encoding:

WT-201: 12-bit digital word, 256 combinations (using first 8 bits), pulse width modulation.

WT-201A: 12-bit digital word, 256 combinations plus selection of up to 16 channels (using last 4 bits).

Power Supply: 12-volt alkaline battery (Duracell MN-21, Golden Power GP-23A, or equivalent).

Attention: Transmitter characteristics may be affected by battery condition.

Operating Temperature: 0° to 49°C (32° to 120°F).

Dimensions: 32 x 53 x 17 mm (1-1/4 x 2-1/8 x 11/16 in.).

Weight: 22 g (0.7 oz).

Color: White.

Compliance with Standards: Meets the requirements of FCC Part 15. **FCC ID:** GSAWT201C

CANADA: 1467 101 534.

Also meets MPT-1340, ETS 300 220, ETS 300 339 and ETS 300 683.

3. INSTALLATION

3.1 Battery Installation

A. WT-201 and WT-201A

- (1) Insert an 1/8 inch screwdriver blade in the slot at the bottom of the case, and follow the steps shown in Figure 2.

Warning! Do not open the case by inserting a screwdriver in places other than the slot. This can damage the transmitter.

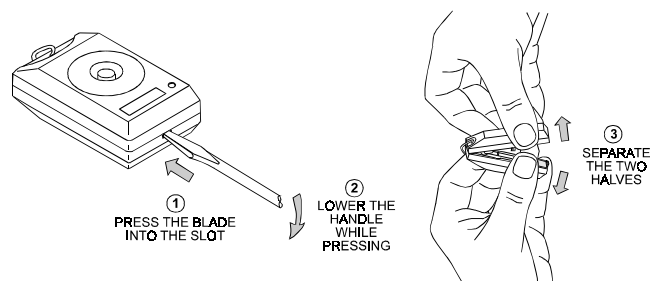

Figure 2. Opening the Case

- (2) Insert the 12-volt alkaline battery (Duracell MN-21 or Golden Power GP-23A or equivalent) between the battery clips, so that the (+) and (-) markings on the battery coincide with the markings near each battery clip - see Figure 1. Check that the battery is held securely by the battery clips.
- (3) Gently press the pushbutton switch and verify that the LED lights, indicating good battery condition.
- (4) Carefully engage the ridges at the top end of the rear cover with the dents at the top end of the front cover. Gently press together the bottom ends of both covers, until they snap shut.

B. Waterproof Version WT-201WP

Waterproof units are shipped fully assembled but not closed, to permit insertion of the battery before final sealing. The case is made waterproof when its two halves are assembled and secured together with 4 screws. To prepare the unit for use:

- (1) Separate the two halves of the case and lay the unit down on its back as shown in Figure 3. Insert the 12V battery between the battery clips. Observe polarity!
- (3) Gently press the pushbutton switch and verify that the LED lights, indicating good battery condition.
- (4) Reassemble the two halves of the case and lay the unit face down. Put a screw in each of the four holes on the back (screws are supplied in a small bag packed with the unit). Carefully tighten all 4 screws with phillips screwdriver No. 1. The unit should now be watertight and ready for use.

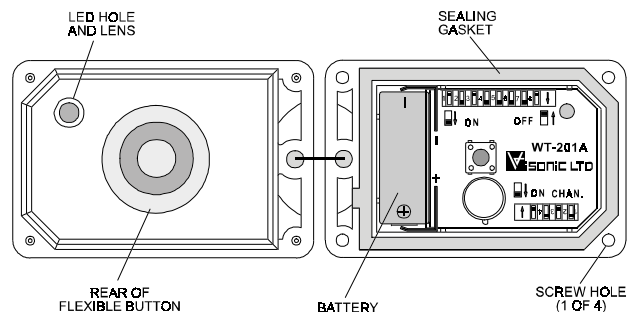

Figure 3. Inside View of the WT-201WP

3.2 Coding

All WT-201 units have an 8-key DIP switch (marked 1 to 8). Each switch may be set to ON or OFF position, to create a unique digital system code - see Figure 4.

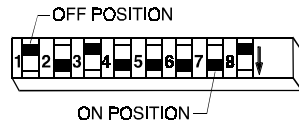

Figure 4. Code Selector

Use a ball point pen to set each of the switches to match the code setting of the companion receiver.

CAUTION: The factory test code (2, 4, 5, 6, 7 ON / 1, 3, 8 OFF) must not be used. Also avoid codes which are often OFF or alternating ON/OFF used: all keys ON, all keys settings.

3.3 Channel Selection (WT-201A only)

Model WT-201A is equipped with a 4-channel selector marked CHAN (see Figure 5). Using this switch you can set the transmitter for activating one of four outputs at the receiver. This feature is important for zoning purposes

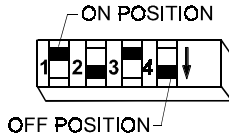

Figure 5. Channel Selector

- activating different alarm zones of a control panel via a companion, multi-channel receiver. The channel data transmitted by the WT-201A is selected by positioning the 4 switches in accordance with the required channel number. Use a ball point pen to set the channel selector as required by the host system.

3.4 Testing

A. Stand 10 feet away from the receiver and operate the transmitter.

- B. Verify that the transmitter LED lights, indicating good battery condition.
- C. Observe that the receiver LED lights, indicating detection of the transmitted RF signal.
- D. Verify activation of the receiver's output relay associated with the channel selected in the transmitter (the WT-201 single-channel transmitter operates the relay associated with channel 1).
- E. Operate the transmitter from various locations within the area covered by the receiver to determine "dead" locations, where transmission is obstructed by walls and large objects, or affected by structural materials.

3.5 Key-Ring Installation

- A. Remove the chain by opening and slipping it through the triangle on top of the WT-201.
- B. Insert the tip of a long-nose pliers into the triangle and open it.
- C. Remove the triangle.
- D. Open the plastic bag which contains the key-ring kit.
- E. Slip the key-ring triangle through the last link of the key-ring chain and install the triangle into the hole on the top of the WT-201 (Figure 6).

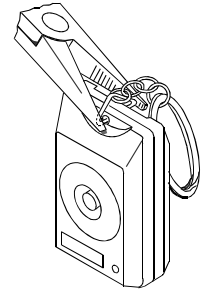

Figure 6. Key-Ring Installation

- F. Using the pliers, close the key-ring triangle.

4. MISCELLANEOUS COMMENTS

4.1 Product Limitations

Our wireless systems are very reliable and are tested to high standards. However, due to their low transmitting power (required by FCC regulations) there are some limitations to be considered:

- A. Receivers may be blocked by radio signals occurring on or near their operating frequencies, regardless of the code selected.
- B. A receiver can respond to one transmitted signal at a time.
- C. Wireless equipment should be tested regularly (at least once a week) to determine if there are sources of interference and to protect against faults.

4.2 Compliance with Standards

WARNING: Changes or modifications to this unit not expressly approved by the party responsible for compliance could void the user's authority to operate the equipment.

The 315 MHz model of this device complies with Part 15 of the FCC Rules and RSS-210 of Industry and Science Canada. Operation is subject to the following two conditions: (1) This device may not cause harmful interference, and (2) this device must accept any interference that may be received, including interference that may cause undesired operation.

WARRANTY

Visonic Ltd. and/or its subsidiaries and its affiliates ("the Manufacturer") warrants its products hereinafter referred to as "the Product" or "Products" to be in conformance with its own plans and specifications and to be free of defects in materials and workmanship under normal use and service for a period of twelve months from the date of shipment by the Manufacturer. The Manufacturer's obligations shall be limited within the warranty period, at its option, to repair or replace the product or any part thereof. The Manufacturer shall not be responsible for dismantling and/or reinstallation charges. To exercise the warranty the product must be returned to the Manufacturer freight prepaid and insured.

This warranty does not apply in the following cases: improper installation, misuse, failure to follow installation and operating instructions, alteration, abuse, accident or tampering, and repair by anyone other than the Manufacturer.

This warranty is exclusive and expressly in lieu of all other warranties, obligations or liabilities, whether written, oral, express or implied, including any warranty of merchantability or fitness for a particular purpose, or otherwise. In no case shall the Manufacturer be liable to anyone for any consequential or incidental damages for breach of this warranty or any other warranties whatsoever, as aforesaid.

This warranty shall not be modified, varied or extended, and the Manufacturer does not authorize any person to act on its behalf in the modification, variation or extension of this warranty. This warranty shall apply to the Product only. All products, accessories or attachments of others used in conjunction with the Product, including batteries, shall be covered solely by their own warranty, if any. The Manufacturer shall not be liable for any damage or loss whatsoever, whether directly, indirectly, incidentally, consequentially or otherwise, caused by the malfunction of the Product due to products, accessories, or attachments of others, including batteries, used in conjunction with the Products.

The Manufacturer does not represent that its Product may not be compromised and/or circumvented, or that the Product will prevent any death, personal and/or bodily injury and/or damage to property resulting from burglary, robbery, fire or otherwise, or that the Product will in all cases provide adequate warning or protection. User understands that a properly installed and maintained alarm may only reduce the risk of events such as burglary, robbery, and fire without warning, but it is not insurance or a guarantee that such will not occur or that there will be no death, personal damage and/or damage to property as a result.

The Manufacturer shall have no liability for any death, personal and/or bodily injury and/or damage to property or other loss whether direct, indirect, incidental, consequential or otherwise, based on a claim that the Product failed to function. However, if the Manufacturer is held liable, whether directly or indirectly, for any loss or damage arising under this limited warranty or otherwise, regardless of cause or origin, the Manufacturer's maximum liability shall not in any case exceed the purchase price of the Product, which shall be fixed as liquidated damages and not as a penalty, and shall be the complete and exclusive remedy against the Manufacturer.

Warning: The user should follow the installation and operation instructions and among other things test the Product and the whole system at least once a week. For various reasons, including, but not limited to, changes in environmental conditions, electric or electronic disruptions and tampering, the Product may not perform as expected. The user is advised to take all necessary precautions for his/her safety and the protection of his/her property.

6/91



VISONIC LTD. (ISRAEL): P.O.B 22020 TEL-AVIV 61220 ISRAEL. PHONE: (972-3) 645-6789, FAX: (972-3) 645-6788

VISONIC INC. (U.S.A.): 10 NORTHWOOD DRIVE, BLOOMFIELD CT. 06002-1911. PHONE: (860) 243-0833, (800) 223-0020 FAX: (860) 242-8094

VISONIC LTD. (UK): UNIT 1, STRATTON PARK, DUNTON LANE, BIGGLESWADE, BEDS. SG18 8QS. PHONE: (01767) 600857 FAX: (01767) 601098

©VISONIC LTD. 1998 WT-201 D-2061-0 NEW: DE2061- (REV. 4, 4/98)

