

Xpelair Wiring Diagrams

Xpelair Premier DX180 & DX180T/H

Premier DX180

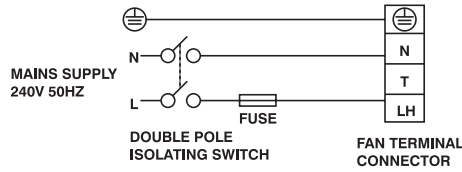

Premier DX180T/H

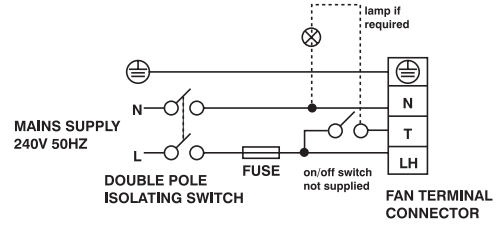

Xpelair Premier DX200 & DX200T

Premier DX200

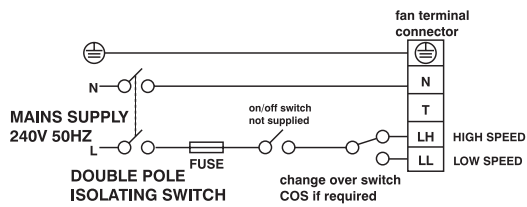

Premier DX200T

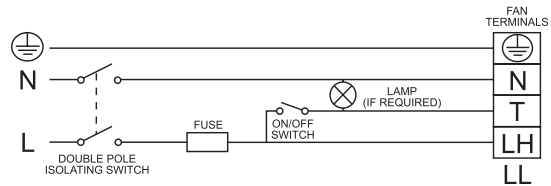

Xpelair Premier CF20 & CF20T

Premier CF20

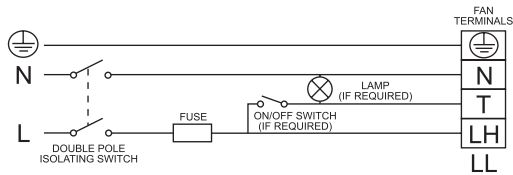

Premier CF20T

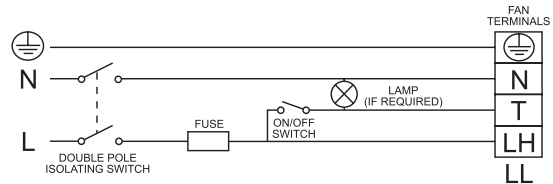

Xpelair Premier LoVolt DX200 & LoVolt CF20

Premier LoVolt DX200T

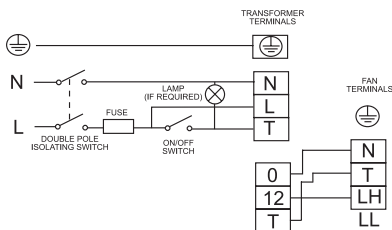

Premier LoVolt CF20

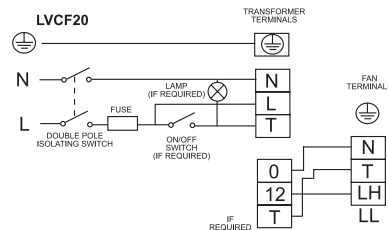

Premier LoVolt CF20T

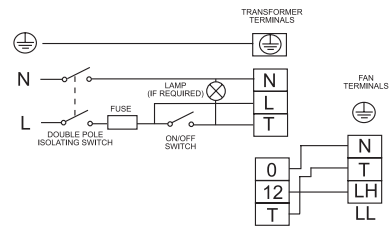

Xpelair DX100 & XX100

DX100/PC/HP/PIR/XX100/P

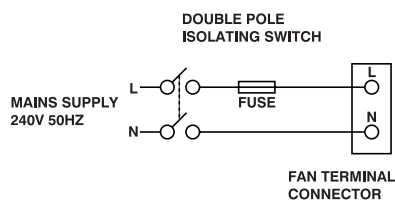

DX100T/H/XX100T

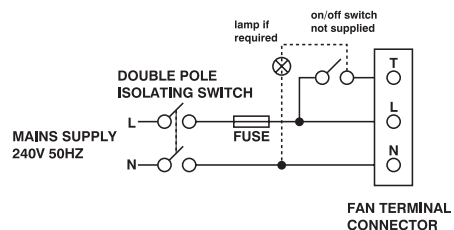

Xpelair LoVolt LV100

LV100/PC/H/HP/PIR

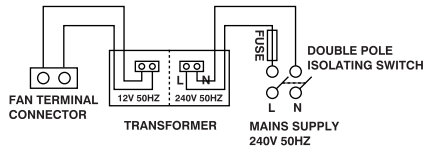

LV100T

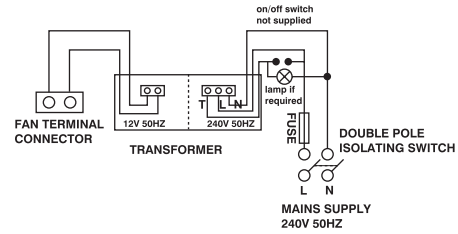

Xpelair Slimline SL100, SL100P & SL100T/HT

Slimline SL100

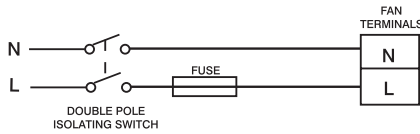

Slimline SL100P

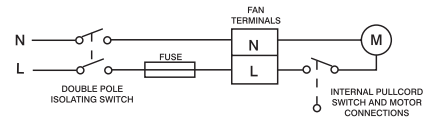

Slimline SL100T/HT

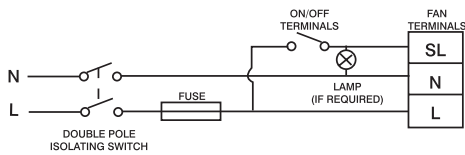

Xpelair CentrX

CentrX CT100/100+/100+P

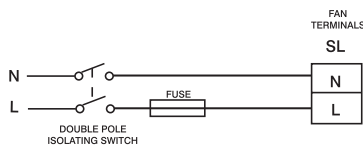

CentrX CT100T/HT/100+HT

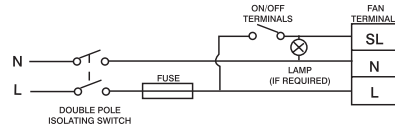

Xpelair XIL Inline shower fan systems

XIL100/125/150/XXS100

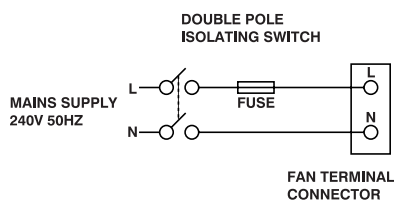

XIL100T/125T/150T/XXS100T

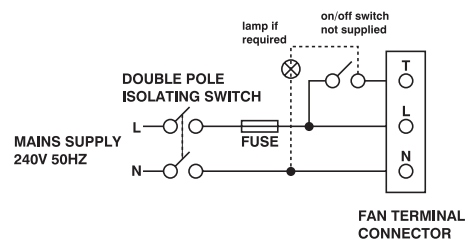

Xpelair Wiring Diagrams

Xpelair BriteX LoVolt & BriteX Turbo

BX100W/C/BX100+W/C

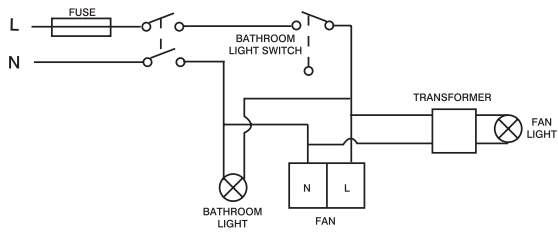

BX100WT/CT/BX100+WT/CT

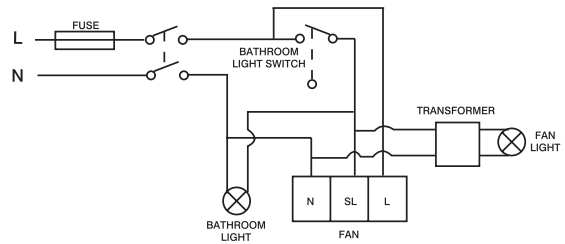

Xpelair XIM

XIM100/100+/125

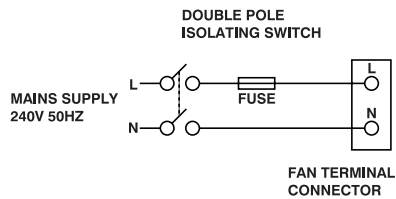

XIM100T

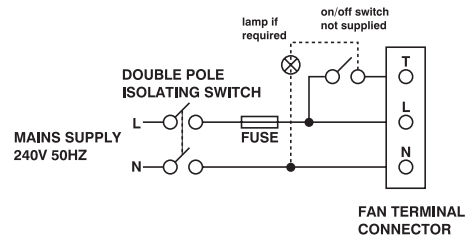

XIM150/200

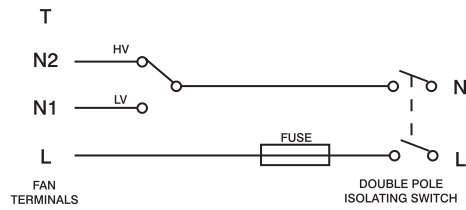

XIM150T

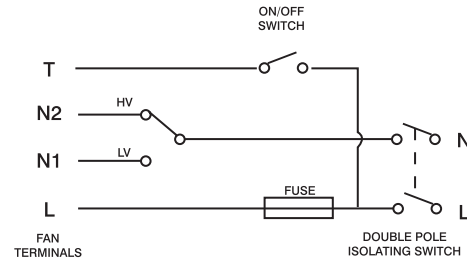

Xpelair Slimline 150

Slimline SL150

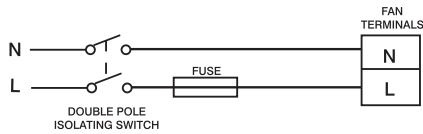

Slimline SL150P

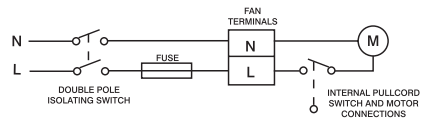

Slimline SL150HT

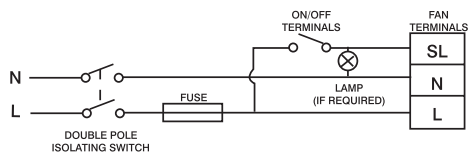

Xpelair GX6, GXC6 & GXC9

GX6

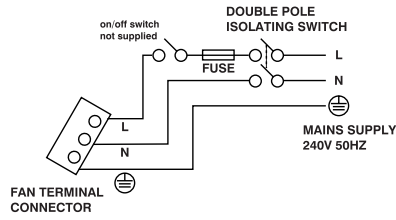

GXC6, GXC6T, GXC6SC & GXC9

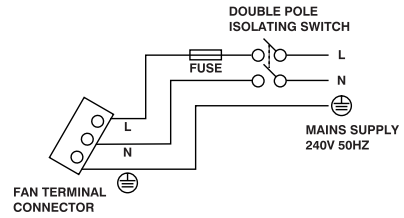

Xpelair Premier DX400 & CF40

DX400

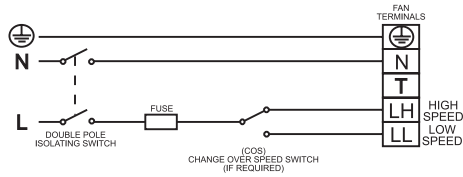

DX400PC

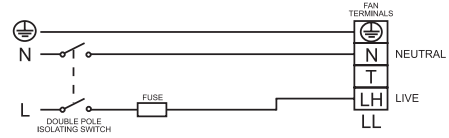

DX400T/CF40/CF40TD

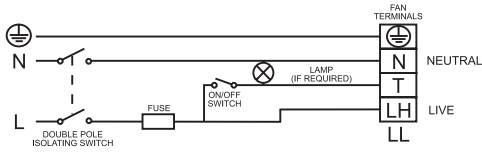

DX400RS/CF40RSTD

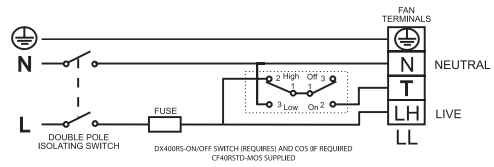

Xpelair Wiring Diagrams

Xpelair Nouvelle Cuisine

Kitchen Canopies

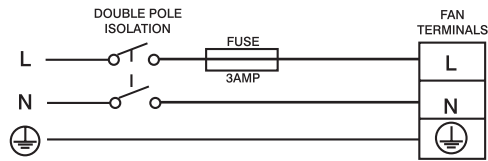

Xpelair CX10 & CMF

CX10/CMF

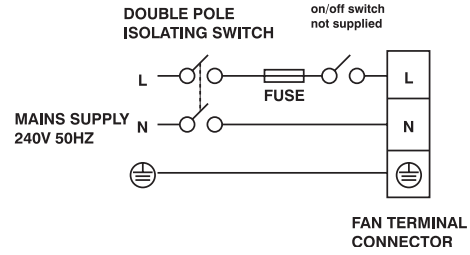

Xpelair Xvent

Xvent275/340

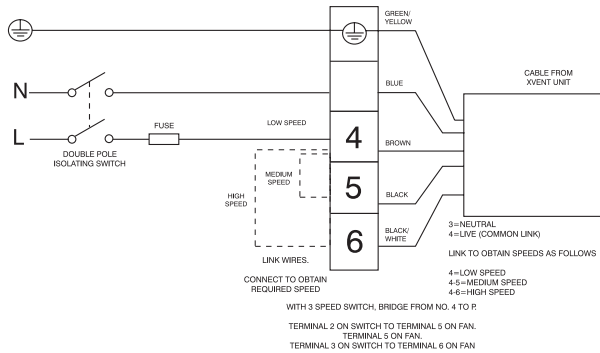

Xvent275/340 with 3 speed switch

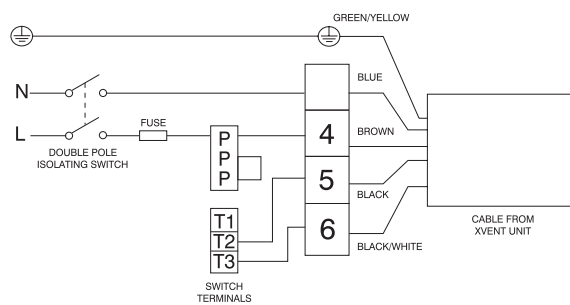

Xpelair Xcell 270 Longlife

Xcell 270

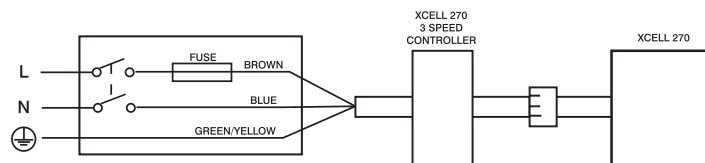

Xpelair Xcell 300 & 400 Longlife

Xcell 300/400

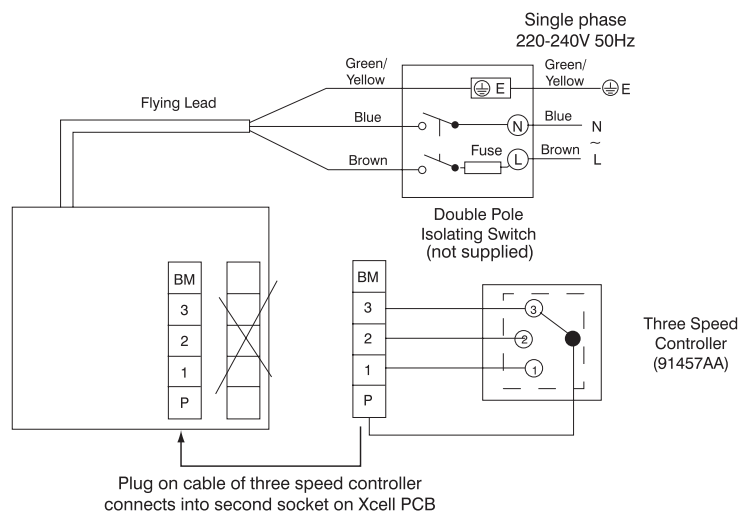

Xpelair EverDri LongLife

EverDri XEDW/XEDL

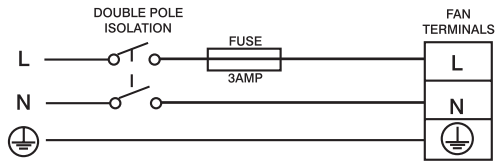

Xpelair LoVolt XHR150

XHR 150

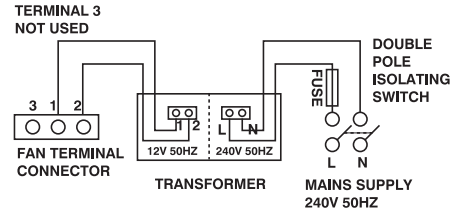

Xpelair GX6, GX9 & GX12

GX6

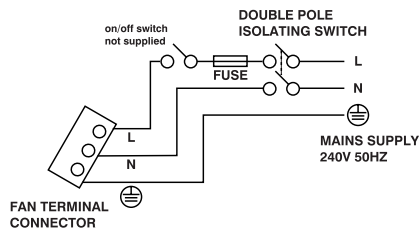

GX9/GX12

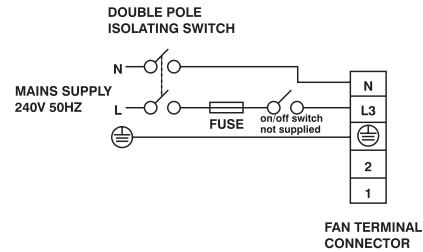

Xpelair PX6, PX9 & PX12

PX6

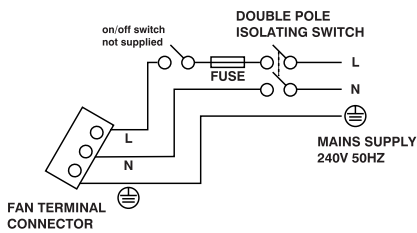

PX9/PX12

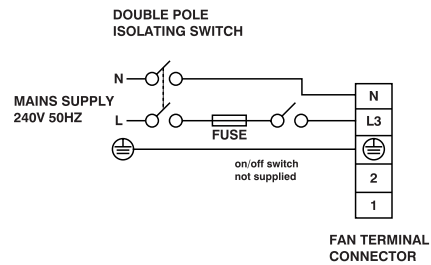

Xpelair RX6, RX9 & RX12

RX6

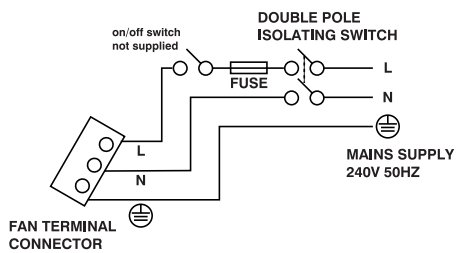

RX9/RX12

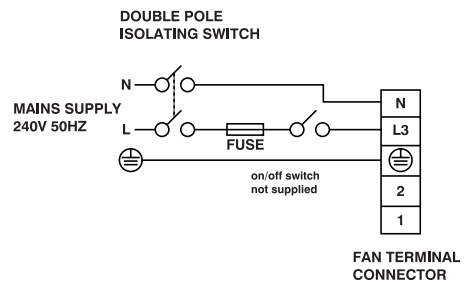

Xpelair Wiring Diagrams

Xpelair WX6, WX9 & WX12

WX6

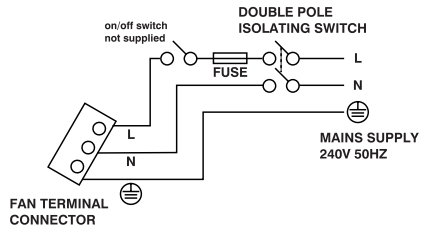

WX6T

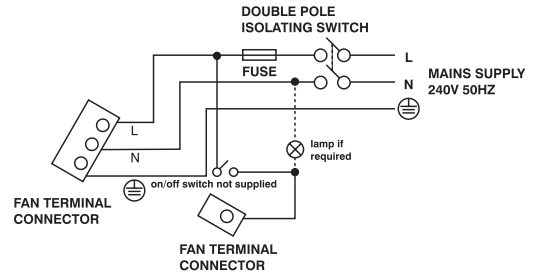

WX9/WX12

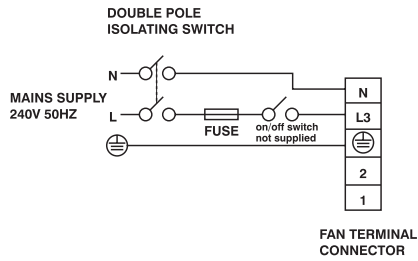

Xpelair ChefX

ChefX Tempo/Presto/Mezzo

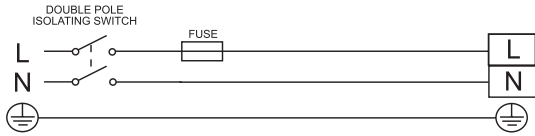

Xpelair WH30 & WHP30

WH30

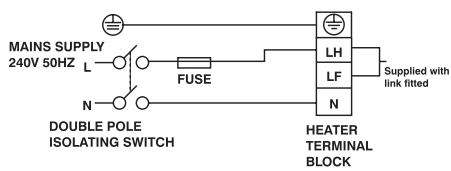

WH30 with HC301

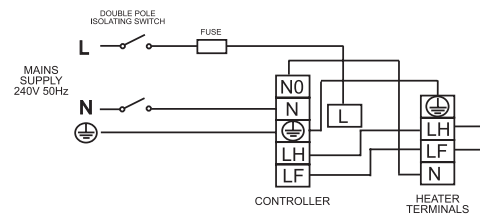

WHP30 with HC301

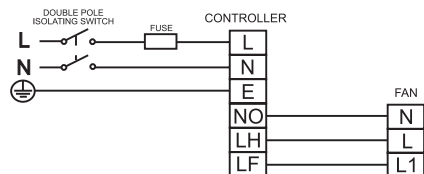

Xpelair WH60

WH60-single phase

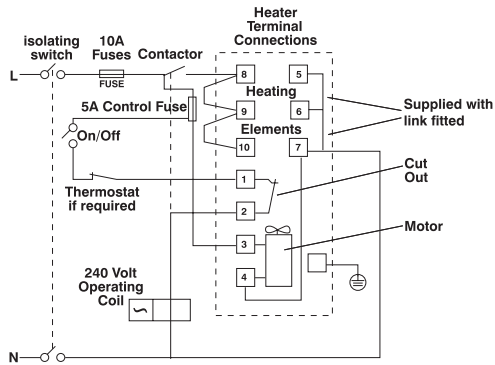

WH60-3 phase using a 240V contactor coil

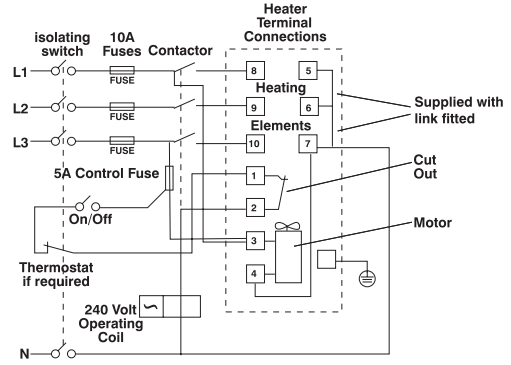

WH60-3 phase using a 415V contactor coil

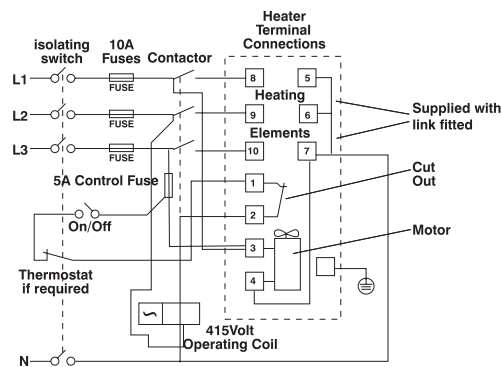

Xpelair ScreenHeat & PlinthHeat

PlinthHeat with integral controls

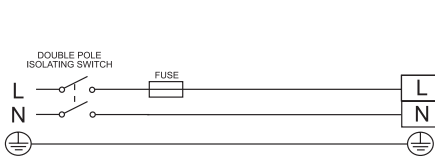

PlinthHeat with remote control

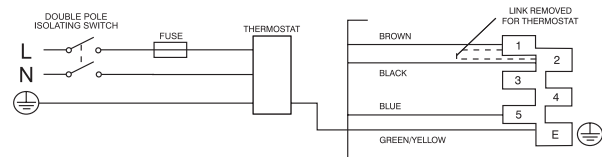

Xpelair Whispair

NWAN

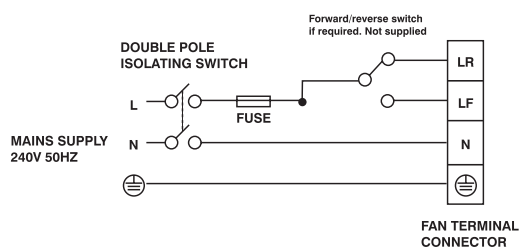

Xpelair Wiring Diagrams

Xpelair XPMS, XPMA & XRA

315/350/400

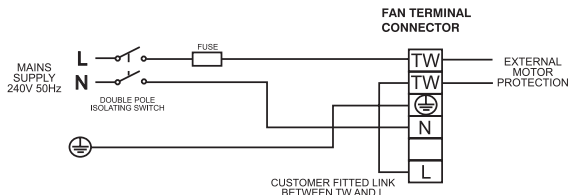

450

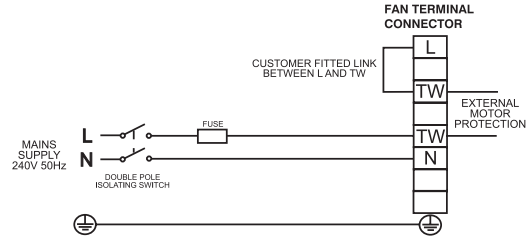

500/630

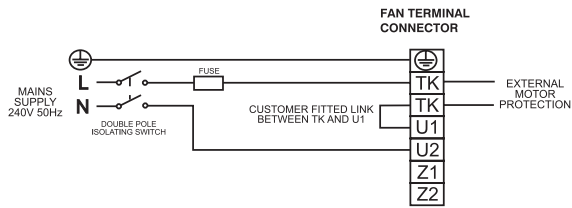

315/350/400 with XCW controller

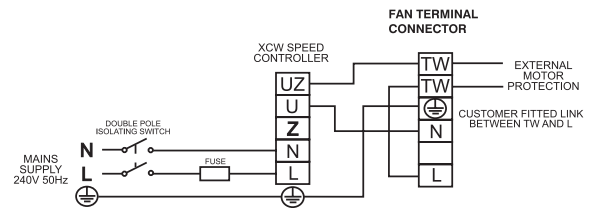

450 with XCW controller

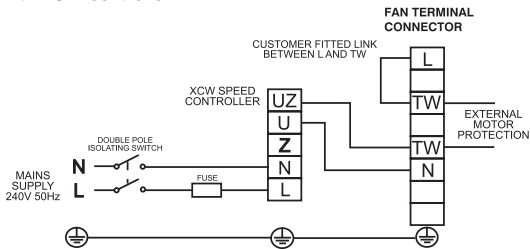

500/630 with XCW controller

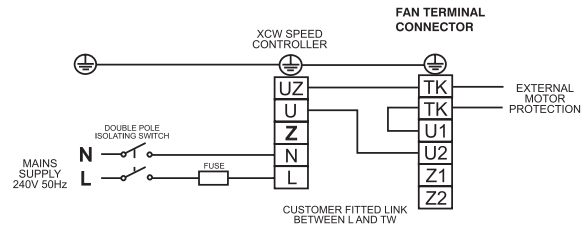

Xpelair XSCS & XSCA

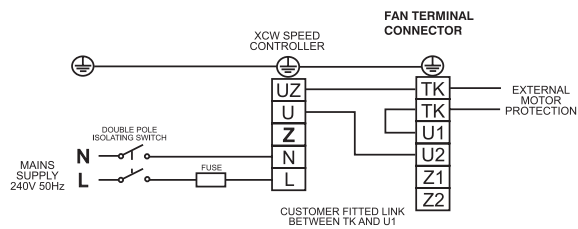

Xpelair XMV

Single phase

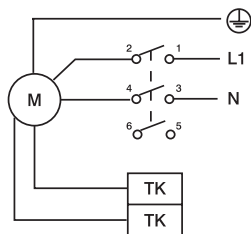

3 phase

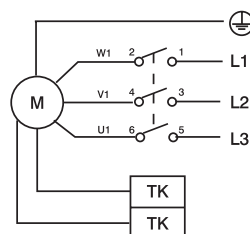

Xpelair XID & XIDP

XID/XIDP

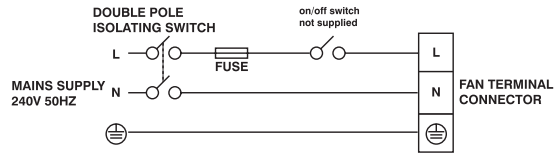

XID/XIDP with XIC1 speed controller

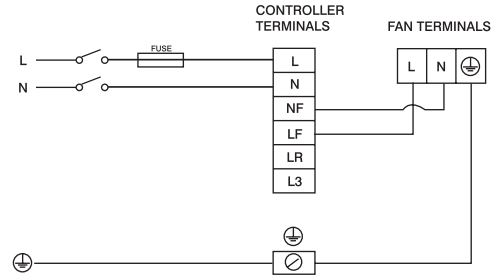

Xpelair LoSound XSFA

XSFA

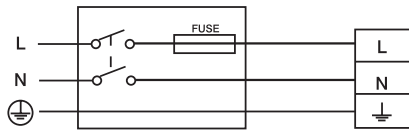

Xpelair SuperBlowers

SB1

