

Domestic HydroTap®

Filtered boiling and chilled drinking water for kitchens.

This Installation Instruction covers the following Domestic HydroTap models

Domestic models:

30009UK - DOMHB1: HydroTap Boiling Only, Unfiltered

37697UK - DOMBA1: HydroTap Boiling & Ambient

437677UK- DOMBC1: HydroTap Domestic Compact Boiling & Chilled



HydroTap



HydroTap with disabled lever kit



Installation Checklist

Before Installation:

- A. Read the instructions
- B. Note: Not all fittings are supplied with the appliance kit. Isolation valves are not supplied
- C. Check the water pressure to determine if you require a pressure reduction valve or flow restrictor added or removed from the kit.
- D. Check the water quality to determine if extra filtration will be required.
- E. Check the appliance rating plate and ensure correct power is available for the appliance.
- F. Check the underbench cupboard supporting the appliance is adequate for the total weight of the appliance, when full of water.

Before commissioning:

- 1. Check the unit has been secured correctly
- 2. Check all plumbing fittings have been tightened
- 3. Ensure the outlet and vent pipes are positioned to drain correctly.
- 4. For undersink units ensure there is adequate ventilation.
- 5. Check all tubes from the undersink unit to the tap, have a constant rise and there are no 'S' traps or kinks in the hoses.
- 6. Check all electrical connections are correct and there are no loose wires.

Commission:

- 7. Flush the supply line before connecting
- 8. Turn on the water and check for leaks.
- 9. Flush the filter.
- 10. Programme (select electronic models) to suit the customer's requirements.

Contents

Read These Warnings First	4, 5
Models covered by these instructions	6
Special tools required	6
Installation Requirements	7
Installation procedure	8
Step A - Installing the tap	8
Step B - Installing the undersink unit	8
See special note page 8, ventilation buffers.	
Step C - Connecting the tap,	9
Step D - Connecting the Water Supply	9
Step E - Testing and commissioning	10, 15
Pull-out Font Template pages	11, 12, 13, 14
Step F - Temp. and Set Point adjustment	15
Font Installation procedure	16
Operating the Tap	17
Child safety lock	18
Setting the Energy Saver Timer	19, 20
Boiling Water Isolation	20
Set the Hot and Cold water dispensing times.	20
Replacing the Filter	21
Cleaning	22
Trouble Shooting	22
End of life disposal	22
Typical undersink layout	23
Warranty & Contact Information.	24

NOTE:

Read all instructions and precautions before proceeding. This unit must be installed in accordance with water supply byelaws, current IEC regulations and relevant local authority byelaws.

Read These Warnings First

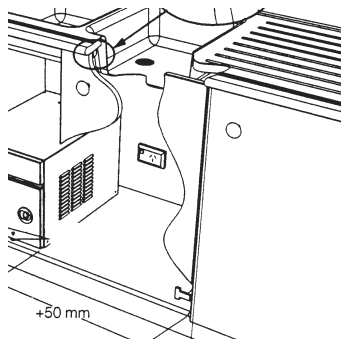

The power point must be located within reach of its cable. The appliance must be positioned so that the plug is accessible.



Typical Zip HydroTap undersink assembly.

NOTE: All appliances must be placed in a horizontal position, as shown above.

Safety

This appliance is not intended for use by persons (including children) with reduced physical sensory or mental capabilities, or lack of experience and knowledge, unless they have been given supervision or instruction concerning use of the appliance by a person responsible for their safety. Children should be supervised to ensure that they do not play with the appliance.

Refrigerant

The Zip HydroTap Chilling unit contains 134A refrigerant under pressure. No part of the unit should be exposed to a naked flame. Maintenance of the refrigeration unit must be carried out by an accredited service provider or qualified refrigeration mechanic.

Qualifications

If any power cord or plug is damaged it must be repaired only by a qualified technician. To avoid hazards, all installation procedures must be carried out by a suitably qualified trades person. The power cord and general power outlet must be in a safe visible position for connection.

Venting

Sometimes steam and / or boiling water may discharge through a vent outlet at the mouth of the tap. If the tap is not installed using the Font pedestal, ensure the tap body is located so the tap outlet safely drains into the sink bowl area.

NOTE: On startup, the controls take the system through a calibration process which causes the unit to over-boil for a period of 45 - 90 secs. This is normal operation, once this mode is completed the system reverts back to normal operation.

Lifting

Take care when lifting the Zip HydroTap undersink unit. Some units may exceed safe lifting limits. Do not lift without assistance. The weights of the units are given in the table under the heading "Installation Requirements". Do not lift the unit by the doors.

Airflow

The ambient temperatures this unit should operate within are 5°C - 35°C. Proper air circulation must be provided. The system will operate satisfactorily only if the recommended air gaps are provided, these are 65mm min rear clearance and 50mm side clearance. Make sure that the ventilation grills of the undersink unit are not obstructed. Included in the installation pack are adhesive backed silicon buffers. If air vents are not installed in the cupboards housing the HydroTap, the buffers must be placed on the inside edge of the cupboard door to create a slight gap ensuring a minimum airflow. Failure to do this may cause the HydroTap to overheat and operate inefficiently.

Altitude (437677UK and 37697UK.)

The Zip HydroTap is equipped with a self-calibrating program which caters for altitude adjustment.

Filter Control (for filtered models)

The Zip HydroTap filter control is preset to 6000 Litres to provide trouble-free flow and operation in most installations. Local water quality conditions may require an alteration to this capacity. In areas where the water has a high concentration of sediment, the preset litre capacity may be shortened to avoid poor flow, taste or odour situations. In areas where the water quality is above average, lengthening the preset capacity may be desirable, but not essential. If any of these changes is needed, follow the instructions on page 17 or contact your Zip Service Provider.

Frost Protection

If this appliance is located where the ambient air temperature could fall below 5°C when the heater is not in use, do not turn off the appliance electrically. This safeguard does not offer the same protection to the connecting pipework and fittings.

Installation Environment Considerations

This unit is intended for indoor use only and should never be installed outdoors or exposed to the elements of nature. This unit must not be positioned in an area that may be cleaned by a water jet. This unit must not be cleaned by a water jet.

Warning:

Zip HydroTaps are designed to operate within 1°C to 2°C of set point for boiling water. For the Domestic Compact model only, the chilled water set point can be adjusted in 1°C increments as follows: 7-11° ; 8-12° ; 9-13° or 10-14°C.

All boiling water units are self calibrating to 98°C, which is the recommended setting. Adjustments to the 98°C setting are not recommended however, under certain circumstances adjustments may be made between 68° - 100°C . The 100°C setting is not recommended as units may discharge or boil over, more frequently.

Adjustments to the set points can only be made within the Service Menu. For details see Step F on page 9.



Caution must be observed when changing any settings within the Service Menu as any changes may affect the normal operation of the unit.

Note:

Always ensure the silicone tubes are shortened so that any excess is removed and their route is the most direct line between the tap assembly and the HydroTap unit.

Do not allow the tubes to sag or droop so water is trapped within the hoses. Always maintain a constant fall

Positioning of the tap assembly must be within the following parameters:

The height between the base of the Hydrotap unit and the base of the Tap assembly cannot be greater than 900mm.

Domestic models covered by these instructions

Model	Height mm	Depth mm	Width mm	Weight empty kg's	Weight full kg's
30009UK	334	320	188	9	11.5
37697UK	337	323	280	9.5	12
437677UK	348	380	385	26	30

Special tools required

In addition to normal tools, the following will be required:

- 35mm diameter sheet metal hole punch for sink tops. (not supplied)
- 35mm diameter hole saw for timber bench tops. (not supplied)
- Nut runner tube spanner (supplied) for fixing tap assembly.

When installing a Font unit:

- For Font installation: a 108mm diameter sheet metal or hole saw to suit surface being cut.

Installation Requirements

Before installing ensure that the following have been provided at the installation site:

- Sufficient space in the cupboard to install the undersink unit in accordance with these Installation Instructions. A table of dimensions is given above.

NOTE: Add 65mm to the Depth of the undersink unit to allow for Water and Electrical connections.

- A water supply connection with isolating valve inside the cupboard within reach of the 750 mm flexible connection and positioned so that the connection point and the stop cock will not be obstructed when the undersink unit is installed.
- A power supply of 220-240 Volt AC, for connection to the heater via a 13 amp fused spur. The power outlet socket must be positioned within 1.8 metres of the under sink appliance so the plug is made accessible after installation.
- This switch must provide all-pole disconnection with a contact separation of at least 3mm, installed in accordance with wiring rules.
- A cold water supply with a minimum working pressure of 0.7 bar and a maximum working pressure of 7 bar connected via an isolation valve. If pressure is likely to exceed 7 bar, install a 5 bar Pressure Limiting Valve.

NOTE: Compact model 437677UK is supplied with a 3.5 bar pressure limiting valve. This valve must be installed between the external service valve and the appliance (see P. 23)

Important:

Do not proceed with the installation if these requirements are not met.

Installation procedure

NOTE: Typical Layout is shown on P27

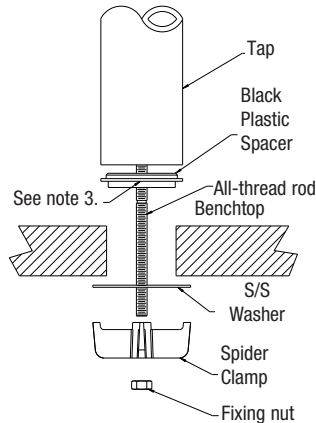

Note: A stainless steel washer is supplied to go in between the Spider Clamp and the underside of the sink top. See location as shown.

Step A - Installing the tap

1. Make sure that the tap location will allow the nozzle to drain into the sink.
2. Install the 35mm hole in the bench / sink top.
3. Ensure the black plastic spacer remains in place as this is the moisture seal against the bench / sink top. **A light smearing of silicon sealant on the underside of the spacer will ensure a watertight fit.**
4. Pass all three hoses through the 35mm hole and carefully locate the Head Assembly and black spacer on the bench / sink area.
5. From the underside of the bench / sink area install the S/S washer and "Spider Clamp" by feeding each of the three tubes and electrical cable evenly in between the legs of the "Spider Clamp". Slide it up to meet the "All Thread", and pass the "All Thread" through the centre of the "Spider Clamp".
6. Hold the "All Thread" steady and fit the 6mm nut to the "All Thread" using the tube spanner supplied in the kit. Check the Tap Head position before securing it tightly against the bench / sink top.

NOTE 1: The tap assembly must not be positioned more than 900mm above the base of the HydroTap unit

Failure to do this may result in poor water delivery.

NOTE 2: Under no circumstances should the Tap be twisted after the installation is complete.

Step B - Installing the undersink unit

SPECIAL NOTE: The HydroTap undersink units are heavy, take note of the weights listed in the table on page 4. If you think you cannot lift the unit safely, get help and avoid possible injury.

Before positioning the heater connect the braided water inlet hose (supplied) to the cold water inlet on the unit. This is located at the rear of the unit.

Position the Zip HydroTap undersink unit as close as possible to directly beneath the Zip HydroTap tap head.

The connection tubes supplied with the tap head assembly CANNOT be lengthened.

Leave at least a 50 mm air-gap without obstruction on each side of the unit and 65mm at the rear

Adjust both cupboard door hinges and attach the supplied rubber door buffers to the doors to create a 4 mm air-gap between the doors and the cupboard. This is the minimum ventilation requirement for low usage installations.

Note: Ventilation Buffers

Included in the installation pack are adhesive backed silicon buffers. If air vents are not installed in the cupboards housing the HydroTap, the buffers must be placed on the inside edge of the cupboard door to create a slight gap ensuring a minimum airflow. Failure to do this may cause the HydroTap to overheat and operate inefficiently.

Step C - Connecting the tap

Boiling ambient model

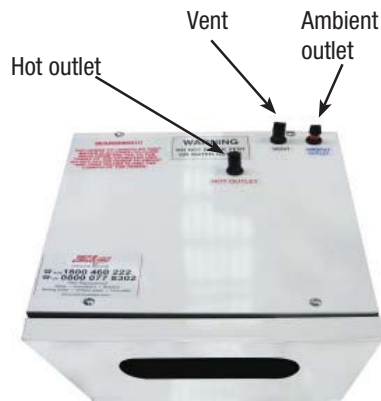

Models 30009UK and 37697UK

Measure and trim the red marked tube and / or the blue marked tube and connect it to the hot water outlet and ambient outlet (if an ambient model), on the top of the undersink unit. Use spring clamps provided. Measure and trim the unmarked tube and connect it to the vent outlet on the top of the undersink unit. Use spring clamps provided.

NOTE: All tubes must have a continuous fall back to the undersink unit.

Connect the tap USB connector to the USB port on the undersink unit. Orient the USB plug carefully and connect, do not force the plug. Once connected, fix the cable to the wall, ensure it is away from any possible water splashes and is off the floor.

NOTE: When trimming any silicon tubes trim to minimum length, do not loop any excess or allow kinking of the tubes. When connecting, slide the tube over the pipe at least 25mm. There are black plastic clamps provided on the boiling and chilled hoses to choke the flow if required. Only choke the flow if it is excessively strong.

Model 437677UK - Domestic Compact Boiling /Chilled.

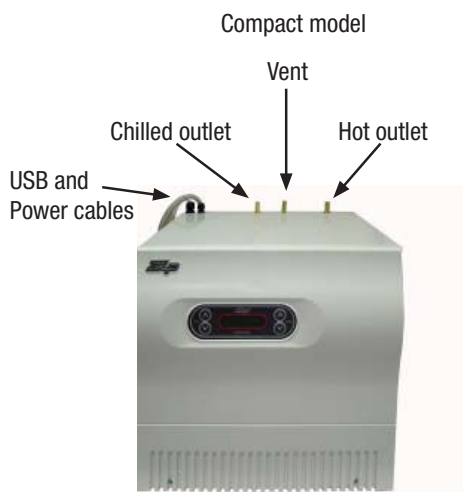

Model 437677UK - Domestic Compact Boiling /Chilled.

Measure and trim the blue tube and connect it to the chilled water outlet located on the top rear, left hand side of the undersink unit. Use spring clamps provided.

Measure and trim the red marked tube and connect it to the hot water outlet located on the top rear, right hand side of the undersink unit. Use spring clamps provided.

Measure and trim the unmarked tube and connect it to the vent outlet located on the top rear centre of the undersink unit. Use spring clamps provided.

NOTE: All tubes must have a continuous fall back to the undersink unit.

Connect the tap USB plug to the USB cable mounted socket from the undersink unit. Orient the USB plug carefully and connect, do not force the plug. Once connected, fix the cable to the wall, ensure it is away from any possible water splashes and is off the floor.

Step D - Connecting the water supply

To prevent sediment from entering the Zip HydroTap at connection, flush water through the supply line thoroughly before connection to the Zip HydroTap. Open the access door and check that the filter is in place and secure. Connect the water supply to the undersink unit using the attached flexible hose. Turn on water and check for leaks. If no leaks are evident turn the power on.

Step E - Testing and commissioning

(applies to all models except HT boiling only)

NOTE :

New hose sets supplied with the unit should be used. Do not use old hose sets.

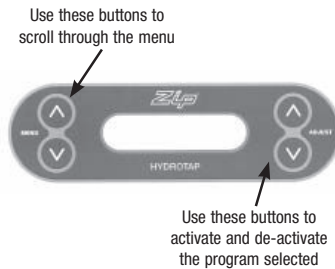

Filter Flush Mode (filtered models only)

The display screen will show which model you have. Have a bucket or similar container (not supplied) at the ready to hold a quantity of water that is ejected while the Filter Flush Mode is in operation. Open the filter access door on the front of the HydroTap and the filter cartridge will be exposed (or undo 2 screws near the lower corners of the compact model to remove the front cover). Located to the rear RHS of the cartridge is a fixed flush line, approx 600mm long and the flush line stop cock. Place the free end of the flush line into the bucket or container (not supplied).

Turn "ON" both water and electricity supplies and open the flush line stop cock. The display will show Filter Flush Menu. To activate press adjust ▲ and run at least 7.5 Ltrs of water through to activate the filter membrane. Press the adjust ▲ button again to stop the Filter Flush Mode. Turn OFF the Filter Flush stop cock and re-locate the tube and stop cock in the filter compartment. Turning OFF the Filter Flush Mode puts the HydroTap into calibration mode. Press adjust ▲ to start calibration. The element will now cycle On and heat the water to 95°C maintaining it at that temperature for a short stabilisation period.

Once stabilised, the element will cycle On, bring the water to boiling point and hold it there for a short period.

Calibration

The unit now carries out a self calibration function to ensure correct temperatures are maintained. During this period the Red LED on the Tap Head assembly flashes slowly until the calibration function is complete.

Once this step is complete (approx 5 minutes) the unit will default to normal operation.

When starting, both Boiling and Chilled cycles activate simultaneously after calibration has taken place, the descriptions below indicate what happens during each cycle.

Boiling

The unit is now running in normal operating mode. The Red LED will flash until usable temperature is reached.

Before using the HydroTap wait 5 minutes after this point to allow adequate fill time. The unit is now ready for use. Use cable clips (not supplied) to tidy and secure wiring.

Chilled (excluding Domestic Compact model)

When water and power are turned On, the Blue LED flashes slowly on the Tap Head assembly. The compressor activates and water begins to fill the chiller tank at the prescribed rate. When the water is chilled to 10°C the Blue LED on the Tap Head assembly stops flashing and stays illuminated.



Continued on P. 15

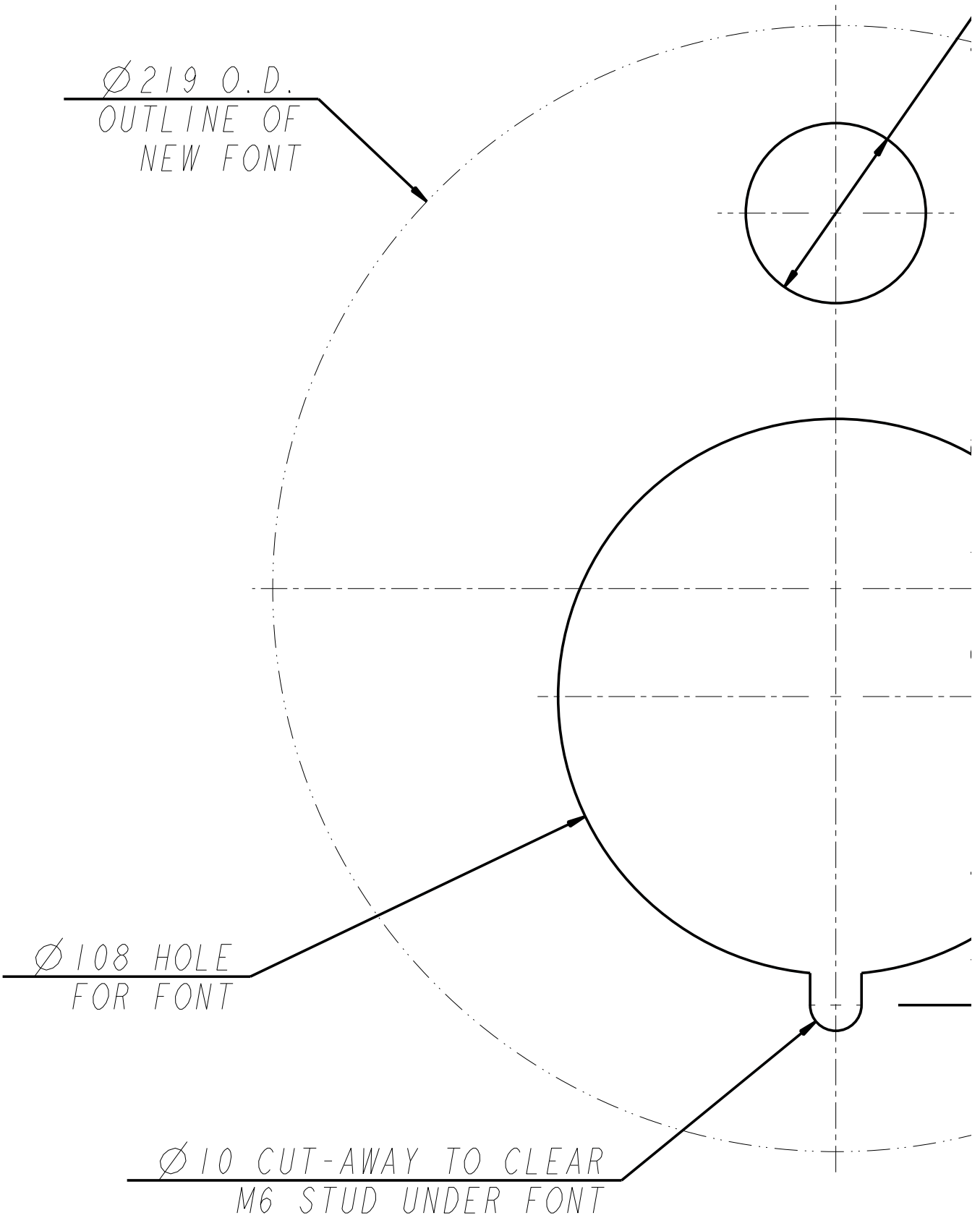

$\varnothing 219$ O.D.
OUTLINE OF
NEW FONT

$\varnothing 108$ HOLE
FOR FONT

$\varnothing 10$ CUT-AWAY TO CLEAR
M6 STUD UNDER FONT

$\varnothing 35.0^{+0.5}_0$ HOLE FOR TUBES
FROM TAP TO GO THROUGH

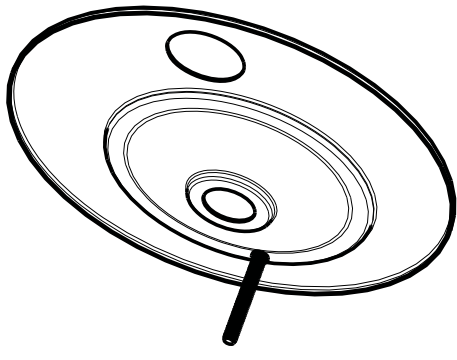
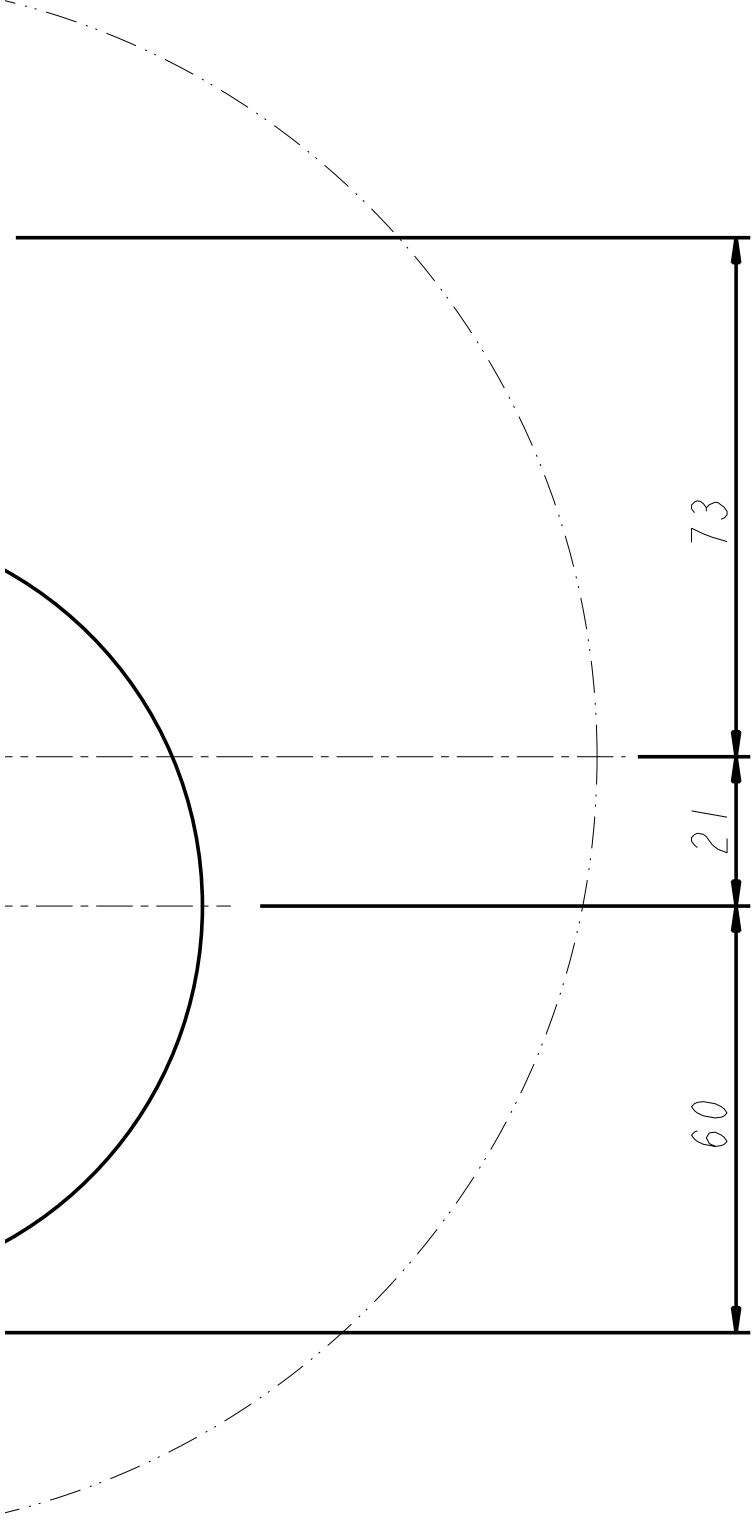

SCALE 0.300

Chilled - Domestic Compact model

When water and power are turned On, the Blue LED flashes slowly on the Tap Head assembly. The cold tank must be filled with water manually. Press the chilled water lever on the tap head and hold the lever down until cold water flows from the spout, then release. The compressor will start and when the water is chilled to 10°C the Blue LED on the Tap Head assembly stops flashing and stays illuminated.

Ensure that the clock matches your local time. If not refer to page 19. If Energy Saver Settings are required, the instructions for installing these are described on page 19 "Setting the Energy Saver Timer".

Step F - Temperature set point adjustment

(Not normally required)

Temperature and Water level screen: (Service Default Screen)

To access this default screen, on the right hand side of the screen, press the 'A' adjust buttons together until the screen changes to Service Mode, it will show the following:



NOTE: The temperatures shown are actual, not the set temperatures. To revert back to the Normal Operation screen, press the adjust buttons together again until screen changes.

→ Press the Menu plus button, **ONCE**, to enter **the Hot Temperature Adjustment Screen:**

Here you can adjust the Hot temperature set point by pressing the **A** adjust \wedge or \vee buttons. The Hot temperature set point can be raised or lowered in 0.5°C increments between 68° - 100°C. **Note:** the Maximum setting of 100°C is not recommended for normal use. Do not raise temperature above 98.5°C without consulting Zip first to discuss the service issue.

→ Press the Menu minus button, **ONCE**, to return to **the service default screen:**

NOTE: On the Compact model the cold temperature set point can be adjusted as follows:

→ Press the Menu minus button, **ONCE**, to enter **the Cold Temperature Adjustment Screen :**

Here you can adjust the Cold temperature set point by pressing the **A** adjust \wedge or \vee . The cold temperature set point can be changed in 1°C increments as follows: 7-11° ; 8-12° ; 9-13° or 10-14°C.

→ Press the Menu plus button, **ONCE**, to return to **the service default screen**

To change the service default screen back to Normal Operation, press the adjust buttons together until the screen changes back.

Warning:



Caution must be observed when changing any settings within the Service Menu as changes may affect the normal operation of the unit.

Font installation procedure

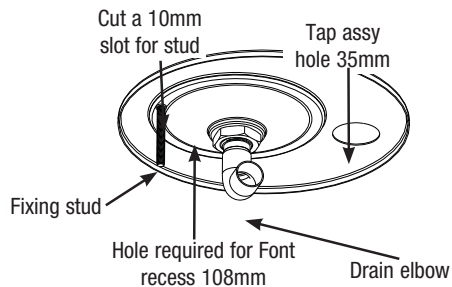

View from underside

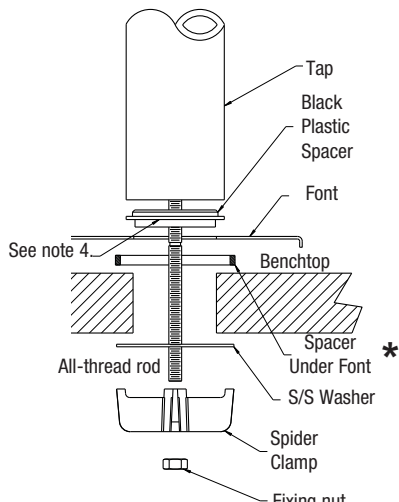

Note: A stainless steel washer is supplied to go in between the Spider Clamp and the underside of the benchtop. See location as shown.

1. Position the Font template (provided) on the bench area. Ensure the position you select is within the length of the supply tube and USB cable fixed to the Tap Head Assembly. These cannot be extended.
2. Check again for correct positioning. The supply hoses must have constant fall back to the tank assembly. Cut the holes as shown on the template.
3. Once holes are cut, locate the Font base in position, from the underside, lightly tighten the securing rod with the nut and washer provided.
4. Apply a light smear of silicon sealant to the underside of the black base ring, this will provide a water tight seal against the Font base when clamped.
5. Now take the Tap Head Assembly. Feed the hoses and USB cable through the Font base, then through the plastic spacer that sits under the font base but on the bench top. * Ensure the plastic spacer is correctly located under the Font as this stops warping of the base plate. Ensure the Tap spout is directly centred over the Font drain. Fit the "Spider Clamp", nut and washer onto the "All Thread". Have all the supply tubes and USB cable located evenly between the "Spider Clamp" legs. When satisfied with the positioning, tighten the fixing nut with the Tube Spanner provided in the kit.
6. Tighten the securing pin so the Font base is flush with the bench top.

NOTE: The fixing nut above the drain elbow can be loosened to correctly position the direction of the elbow. Ensure when the re-positioning is complete the nut is re-tightened to ensure a water tight seal.

7. Connect a drain hose (22mm ID) from the Font base outlet elbow to the closest drain trap spigot available. If a spigot is not available use the snap on spigot and worm drive clamps supplied in the kit. (Instructions and diagrams are supplied in the kit ref:81496).
8. Ensure the positioning of the snap-on spigot is on the "sink" side of the trap and not the "waste" side. Once positioned, a hole (13mm ID) will need to be drilled to provide waste access to the drain line. The snap-on unit will require suitable sealant to keep it water tight against the waste pipe. Finish by fitting the worm drive clamps tightly on either side of the spigot and fitting worm drive clamps to either end of the drain hose. The drain hose from the Font must have constant fall
9. Connect the Tap head Assembly supply hoses and vent as per the instructions contained in the installation procedure section of this document.

Operating the Tap

Blue Chilled Water Light

On all the time:

This indicates that the temperature of the chilled water is within the usable temperature range.

Flashing slowly :

This indicates that the chilled water is not at the right temperature. Wait up to 20 minutes. When the chilled water is at the right temperature, the light will stop flashing. Note: The Zip HydroTap is designed to dispense chilled water in the temperature range 7°C to 14°C.

During heavy usage, the temperature can rise out of this range.



Note: On the Boiling only models the Chilled LED is blank.

Red Boiling Water Light

On all the time:

This indicates that the boiling water is ready.

Flashing slowly :

This indicates that the boiling water is below usable temperature.

Filter light

Filter Change Light Off:

This indicates the filter is operating within its normal specified life span.

Filter Change Light Flashing slowly :

The light will flash slowly when the filter is due for replacement and the LCD will show "Filter Change". Refer to "Replacing the filter" section of this document.

Child Safety Lock (boiling / chilled models)

The child safety lock can be activated to prevent boiling water flowing if the hot lever is inadvertently activated.

To activate, first press the safety lock then depress the Blue Chilled water lever for a period of approximately ten seconds. The safety lock indicator light will now be illuminated.

To de-activate, first press the safety lock then depress the Blue Chilled water lever for a period of approximately ten seconds. The safety lock indicator light will now extinguish.

To operate when the lock is ON, depress both the Red lever and the safety lock simultaneously.

Child Safety Lock (all boiling only models except HT models)

To activate the child safety lock, go to the LCD display, using menu \blacktriangle or \blacktriangledown buttons, scroll to the Safety Lock display. To turn ON adjust \blacktriangle button, to turn OFF adjust \blacktriangledown button. After about 10 seconds the screen will default to the selected mode. When activated the LED on the safety lock will be illuminated. If de-activated the LED will be OFF.

To operate when lock is ON, depress both the Red lever and the safety lock simultaneously.



Child safety Lock

Child safety lock

Child Safety Lock (HT boiling only models)

Pressing the safety lock rapidly three times will either activate or de-activate the safety lock. Indicator light ON means the lock is active, indicator OFF means inactive.

Press or pull lever



Lever Operation

Boiling Water Lever

Depressing the “Red” lever allows dispensing of Boiling water. Pulling up the Red lever allows the tap to operate in a “no-touch” mode. Water will flow from between 5 and 15 seconds (This is user adjustable). To reset, return the handle to the “Off” position and repeat the step. The lever has to be manually returned to the “Off” position.

Chilled Water Lever

Depressing the “Blue” lever allows dispensing of Chilled water. Pulling up the Blue lever allows the tap to operate in a “no-touch” mode. Water will flow from between 5 and 15 seconds (This is user adjustable). To reset, return the handle to the “Off” position and repeat the step. The lever has to be manually returned to the “Off” position.

Setting the Energy Saver Timer (Model: 437677UK)

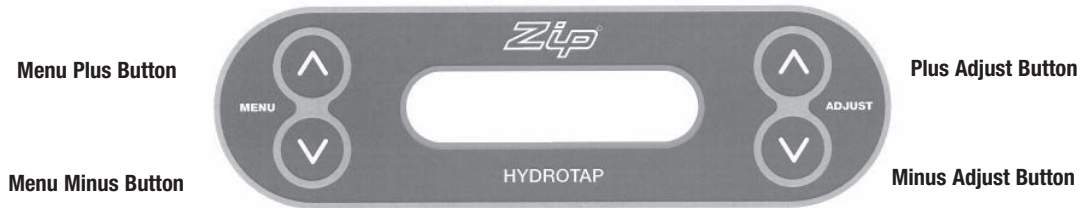

Normal Operation (not available on HT boiling only series)

Set Time

To change time, press either Menu \wedge or Menu \vee button until Set Time is on the display screen. Press \wedge Adjust button to increase time or \vee Adjust button to decrease time. Time increases or decreases in increments of one minute. Hold the Adjust buttons down for rapid increases or decreases. The time will be displayed in 24Hr mode.

Set Language (option for EU models only)

EU models will have the default language set for German. To select English as the default press the \vee Adjust button. To select German as the default Press \wedge Adjust button.

Set Day

Press either Menu \wedge or Menu \vee button until Set Day is displayed.

Press \wedge Adjust or \vee Adjust to select day.

Filter Life (Factory set at 6000 Ltrs)

Press either Menu \wedge or Menu \vee button until Filter Life is displayed.

Press \wedge Adjust button to increase Filter Life or \vee Adjust button to decrease Filter Life.

Filter Life increases in 1000 Ltr increments to a maximum of 10000 Ltrs.

Reset Litres Filtered

This function is to reset the Filter Change display after a filter has reached the end of its life (refer to "Replace Filter Instructions" section of this document).

Press either Menu \wedge or Menu \vee button until "Litres Filtered" is displayed. Press \wedge Adjust once and "Reset Counter" will be displayed, press \wedge Adjust button once and "Are You Sure" will be displayed.

Press \wedge Adjust once and "Litres Filtered" will be reset to 0.

Activating Sleep Mode

This mode allows the HydroTap to go into Energy Saving mode. In this mode the unit will go to "sleep" after a predetermined period of inactivity. Press either Menu \wedge or Menu \vee button until "Sleep Mode" is displayed. Press \wedge Adjust once to select 2 Hours or twice to select 4 Hours. When the period of inactivity passes, the display will show "Sleep Mode". During the "Sleep Mode" the Red LED on top of the tap lever will flash slowly.

To de-activate the sleep mode, momentarily operate the Hot lever and then allow sufficient time for the water to reach the set temperature. When complete, the Red light will stop flashing.

Activating On / Off Mode

Press the Menu \wedge or Menu \vee button until "Monday On" is displayed. To set the time for the unit to turn on press \wedge Adjust button until required time is reached.

To set the time for the unit to turn Off press Menu \wedge button once and "Monday Off" will be displayed. Now press \wedge Adjust until required time is reached.

If each individual day is to have an "On / Off" time, these steps need to be repeated for each day and for each On / Off time.

Note:

Menu buttons change the screen options

Adjust buttons select the screen options

Boiling Water Isolation (Model 437677UK)

The HydroTap is equipped with an additional safety mode that allows protection against accidental operation by Infirm or disabled persons.

1. On the LCD scroll through the menu to Hot Isolation.
2. Press adjust \blacktriangle to activate.
3. Now go to the Tap Head assembly and press the Safety Lock (3) three times rapidly, the LED's will scroll from left to right (3) three times. This operation confirms the activation.
4. This isolates the boiling tap only. The LCD shows isolation mode is active.
5. To de-activate, press the Safety Lock (3) three times rapidly, the LED's will scroll from right to left (3) three times. This operation confirms de-activation.
6. The LCD will show Normal Operation.
7. If de-activation mode is required, de-activate by scrolling through the menu and selecting de-activate when Hot isolation Mode is displayed on the screen.

Set the Hot & Cold water dispensing times

The ability to change the maximum dispensing time for both the Hot and Cold water has been introduced. The default settings for the maximum dispensing times is 15 secs. The ability to change both the Hot and Cold dispensing times between 5 and 15 secs, in increments of 1 sec, is accessible through the Menu screen on the LCD.

Scroll through the Menu until the Dispense Hot screen is displayed, then use the adjust buttons to set the required dispensing time for the Hot water.

Follow the same procedure to access the Dispense Cold or Dispense Amb (on boiling ambient models) screens.

Replacing the Filter (filtered models only)

The Zip HydroTap notifies when filter replacement is due. The default setting is 6000 Ltrs, but this can be set in increments of 1000Ltr from 1000Ltr to 10000Ltrs. When a filter change is due, the Change Filter light will flash white once a minute and remain so until reset. A filter status light is located between the Red and Blue Lights on the tap head assembly.

Depending on local water quality conditions and usage, the filter may require changing anywhere from 1000 Ltrs to 10000 Ltrs. You may also need to replace the filter if you notice unpleasant odours or tastes.

Some water may drip from the filter head (socket) during replacement. Keep a bucket and towel handy to catch drips and mop up any spills.

To change the Filter:

1. Scroll through the screen menu to "Filter Flush Off" this isolates the water supply.
2. Open the left door or on the compact model, remove the front cover by unscrewing the two Phillips headed screws and lift off to expose the filter. Unravel the Blue filter flush line and place the open end in the bucket.
3. Relieve system pressure via the filter flush stop cock, a quick open and close will do.
4. Grasp filter cartridge and twist right to left one quarter turn until it stops.
5. Ease cartridge downwards to detach it from the filter head (socket).
6. Do not tilt the cartridge as dirty water may spill from it if tilted.
7. Unpack replacement cartridge and write today's date where shown on the label.
8. Avoid touching the filter "O" rings and filter opening as this may cause bacterial contamination of the cartridge.
9. Align cartridge tabs with the slots on the under-side of the filter head.
10. Slide cartridge upward into head and rotate left to right until it stops.
11. Locate the filter flush hose situated behind the filter cartridge and run to a container ready for flushing. Open the flush hose tap lever. On the control panel press adjust ▲, this will start the water flushing the cartridge. Allow at least 7.5 Ltrs of water to run through to activate the filter and then press adjust ▲ to stop the flow.
12. Isolate the filter flush stop cock and re-fit behind the filter cartridge.
13. Wipe up any spills and dispose of spent filter cartridge and packaging thoughtfully.
14. Scroll through the menu to "Litres Filtered", press adjust ▲ to reset litre counter. Press adjust ▲ and it asks "are you sure". Press adjust ▲ again to lock in the command.
15. Scroll through the menu to "Filter Used (Days)", press adjust ▲ to reset the timer. Press adjust ▲ and it asks "are you sure". Press adjust ▲ again to lock in the command. After approx 10 seconds it will default to the selected mode.
16. Close the door or refit the front cover to secure the appliance.



HydroTap filter location



Domestic compact filter location

Warning: If the Zip HydroTap is switched off for a long period of time (e.g. More than a weekend), run water through the chilled water outlet for at least 5 minutes before consumption.

Trouble Shooting

Symptom	Possible Cause	Solution
No LED display, no tap head lights or, no water when tap levers are operated.	No power.	Check power supply.
	Plug is not located in power socket.	Ensure power plug is correctly fitted and switch is turned ON.
	Tap loom is not connected to HydroTap unit.	Check loom connection.
	Possible internal fault.	Contact local Zip Service Provider.
	Program in OFF cycle	Check LCD for information.
No water flow.	Water supply isolated.	Check water supply is on.
	Water supply not connected.	Check to ensure plumbing connection is made.
	Power supply not connected.	Check power plug is correctly fitted and switch is turned on.
	Tap loom is not connected to HydroTap unit.	Check for loom connection
	Possible internal fault.	Contact local Zip Service Provider.
	Program in OFF cycle.	Check LCD for information.
Slow water recovery after use.	Filter may require replacement.	Check filter usage on LCD screen, if “filter change” is displayed follow instructions on page 13.
Water not hot.	Unit is in Sleep Mode.	Touch Hot lever and wait for Red LED to stop flashing.
	Unit has just come out of OFF cycle.	Wait for Red LED to stop flashing.
	Possible internal fault.	Contact local Zip Service Provider.
Water not chilled.	Excessive use, unit refilling or chilling down to temperature.	Wait for Blue LED to stop flashing.
	Possible internal fault.	Contact local Zip Service Provider.
Alternating display messages:	More than one fault identified at the same time	Record the number and type of faults Contact local Zip Service Provider

Cleaning

Do not use strong, corrosive, spray or abrasive cleaners. Clean with a soft cloth or brush and mild soap and water.
Do not spray water over the tap as it may damage the low-voltage electronics.
Undersink units must never be located near, or cleaned with water jets.

End of life disposal



The use of this crossed out wheeled bin logo indicates that this product needs to be disposed of separately to any other household waste.

Within each of the European Union member countries, provisions have been made for the collection and recycling of unwanted electrical and electronic equipment. Outside of the EU it will be necessary to dispose of this product at your local community waste collection or recycling centre.

In order to help preserve our environment we ask that you dispose of this product correctly. Please contact your local city council for collection centre details

Typical undersink layout

Domestic Compact model 437677UK shown

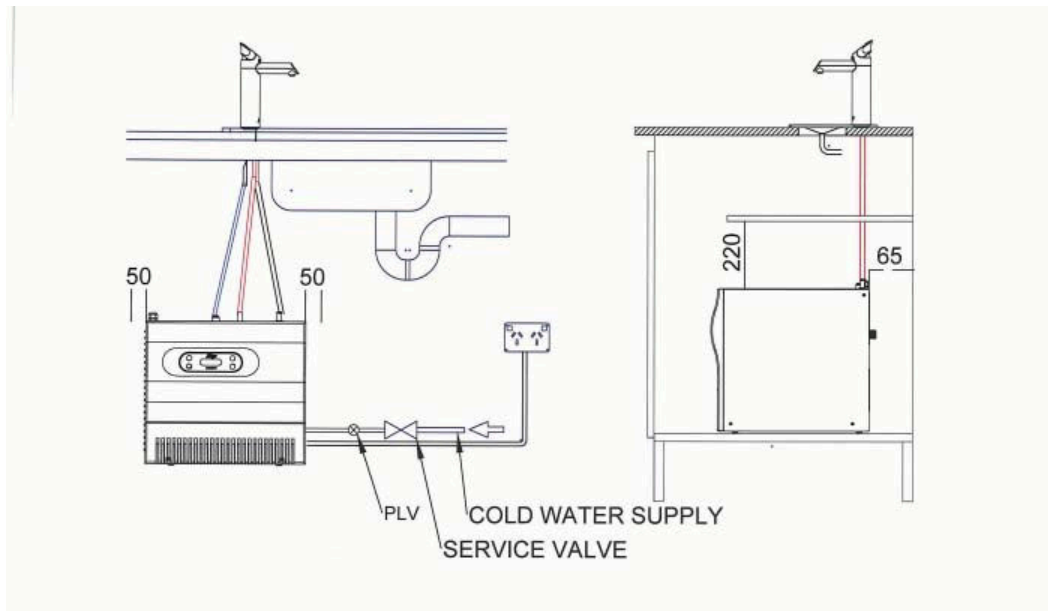

NOTE: The pressure limiting valve (supplied) must be fitted between the external service valve and the appliance



Typical Boiling Only / Boiling Ambient unit



Domestic Compact model 437677UK installation

Warranty

Certain warranties may be implied by law into your contract with Zip. The warranty provided below is additional to these implied warranties and nothing set out below shall limit your statutory rights or rights at law.

Zip Heaters (UK) Ltd warrants that, should any part fail within 12 calendar months of installation, that part will be repaired or replaced free of charge by Zip or its Distributor or Service Provider, except as set out below, provided the appliance is installed and used strictly in accordance with the instructions supplied, and that failure is not due to accident, misuse, abuse, unsuitable water conditions, or to any alteration, modification or repair by any party not expressly nominated by Zip.

No costs are payable by the customer other than any mileage or travelling-time charges incurred by a Zip Service Provider or the cost of removal, cartage and re-installation of any component of the appliance if it needs to be returned for repair to Zip or its Distributor.

This warranty does not cover damage resulting from non-operation of the appliance, the use of non authorised parts or consequential damage to any other goods, furnishings or property.

No warranty applies to the life of any filtration cartridge installed with the appliance as cartridge life may vary according to water quality and the rate of water consumption.

Zip does not exclude, restrict or modify any liability that cannot be excluded, restricted or modified or which cannot, except to a limited extent, be excluded, restricted or modified as between the owner or user and Zip under the laws applicable.

Furthermore, this warranty does not displace any statutory warranty, but, to the extent to which Zip is entitled to do so, the liability of Zip under any statutory warranty will be limited at Zip's option to the replacement of the appliance or supply of equivalent appliance, the payment of the cost of replacing the appliance or acquiring an equivalent appliance, or the payment of the cost of having the appliance repaired or the repair of the appliance.

Registering Your Purchase

Registering your Zip installation on the Zip website may help to establish date of installation should it become necessary to service the appliance under terms of the Zip warranty. To register your installation go to www.zipheaters.co.uk and look under the heading "Warranty".

Head Office

Zip Heaters (UK) Ltd
14 Bertie Ward Way
Dereham
Norfolk NR19 1TE

Website: www.zipheaters.co.uk
sales@zipheaters.co.uk
Telephone: 0845 602 4533
Facsimile: 01362 692 448.

As Zip policy is one of continuous product improvement, changes to specifications may be made without prior notice. Images in this booklet have been modified and may not be true representations of the finished goods.

The standard cup referred to in this publication is 167 ml (6 fl oz).

The standard glass is 200 ml (7 fl oz).

The terms "Zip" and "HydroTap" are registered trade marks of Zip Heaters (Aust) Pty Ltd.

Zip products described in this publication are manufactured under one or more of the following patents: AU675601, AU637412, AU635979, GB0422305, GB2065848, US4354049, US5103859, US5099825 and SA2006/08043. Other patents are in force and patent applications are pending.

