

# Contents

<b>Specification</b>	<b>2</b>
<b>Performance</b>	<b>2</b>
<b>Dimensions</b>	<b>3</b>
Parts List	<b>3-4</b>
<b>Installation</b>	
Requirements	<b>4-6</b>
Positioning	<b>7-8</b>
Plumbing	<b>8</b>
Electrical	<b>9</b>
Commissioning	<b>9-10</b>
<b>Maintenance</b>	
Precautions	<b>10-11</b>
Schedule	<b>11</b>
Fault Finding	<b>12</b>
Draining	<b>13</b>
De-Installation	<b>13</b>
<b>Warranty</b>	<b>14</b>

**Installation must only be undertaken by a competent person holding a current Registered Operative Identity card for the installation of unvented domestic hot water storage systems issued by an accredited body.**

**The Zip Aquapoint must be installed in accordance with these instructions and all current legislation, codes of practice and regulations governing the installation of unvented hot water cylinders in force at the time of installation.**

# Specification

<b>Product:</b>	Zip Aquapoint III
<b>Type:</b>	Direct unvented
<b>Capacity:</b>	30 litre, 50 litre, 80 litre, 100 litre
<b>Loading:</b>	3.0kW/230v~
<b>Fuse Rating:</b>	15A
<b>Thermostat:</b>	Adjustable 25°C to 75°C
<b>Thermal cut-out:</b>	Manually re-settable set to 84+0/-5°C
<b>Water vessel:</b>	Glass enamelled steel tested to 13 bar. Maximum working pressure 6 bar
<b>Insulation:</b>	High performance foam insulation
<b>Controls:</b>	Pressure reducing valve and line strainer set to 3.5 bar Expansion relief and single check valve set to 6 bar Pressure and temperature relief valve set to 7 bar and 90°C External expansion vessel pre-charged to 3.5 bar Expansion vessel capacity: 5 litre AP3/30, AP3/50 8 litre AP3/80, AP3/100
<b>Approvals:</b>	Zip Aquapoint III complies with LVD and EMC directives and is CE endorsed. Zip Aquapoint III has been examined, tested and found, when correctly fitted, to comply with the requirements of the United Kingdom Water Regulations/Byelaws (Scotland). The product, therefore, is listed under the WRAS (Water Regulations Advisory Scheme) Water Fitting and Materials Directory.

# Performance

Size	Model	Heat up time (15° to 65°C)	Re-heat time (70% vol.)
30 litre	AP3/30	37mins	23mins
50 litre	AP3/50	58mins	38mins
80 litre	AP3/80	88mins	58mins
100 litre	AP3/100	110mins	72mins

## Dimensions

Aquapoint	Capacity (litres)	Width (mm)	Height (mm)	Depth (mm)	Weight Empty (kg)	Weight Full (kg)
AP3/30	30	420	525	445	19	49
AP3/50	50	420	690	445	24	74
AP3/80	80	420	950	445	28	108
AP3/100	100	420	1125	445	31	131

## Parts List

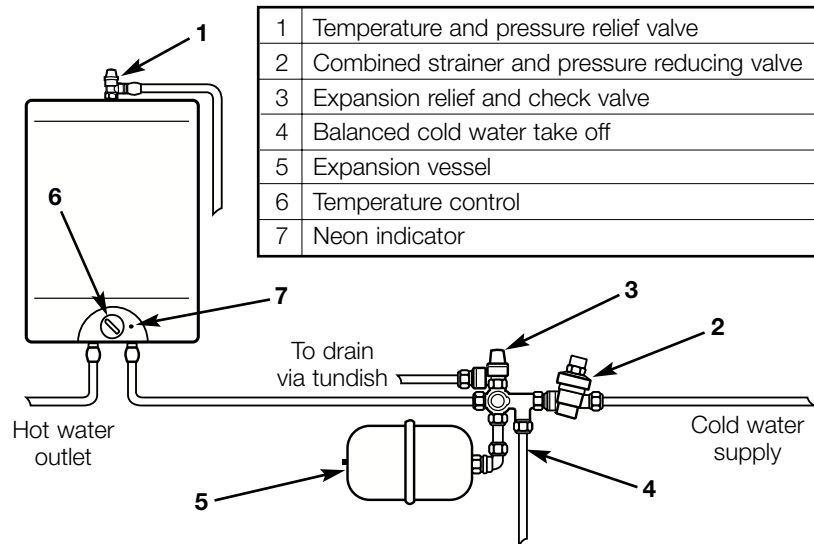

The Zip Aquapoint hot water cylinder will be delivered in its carton with the various control valves and fittings supplied in a separate carton. Both should be left packed until needed.

### Factory Fitted Components

- Heating elements
- Thermostats with over temperature cut-outs
- Pressure and temperature relief valve

### Components supplied with the unit for site fitting

- Inlet manifold assembly comprising pressure reducing valve with integral line strainer and expansion relief valve with check valve and balanced cold water take off.
- Expansion vessel and wall fixing bracket
- Zip Aquapoint hot water cylinder wall locating bracket
- Tundish

## Installation

### Requirements

#### General

Prior to installation the Zip Aquapoint should be kept upright in its original packaging and handled with care always lifting from underneath.

The Zip Aquapoint should be stored in a covered, dry area protected at all times from the weather.

These instructions must be read and fully understood before commencing the installation. If in doubt, or in need of further guidance please ring Zip on 0870 6088888.

Installation must only be undertaken by a competent person holding a current Registered Operative Identity card for the installation of unvented domestic hot water storage systems issued by an accredited body.

The Zip Aquapoint must be installed in accordance with these instructions and all current legislation, codes of practice and regulations governing the installation of unvented hot water cylinders in force at the time of installation.

All connections should be made to the Zip Aquapoint and its safety devices using the 15mm or 22mm compression fittings, nuts and olives supplied.

The electrical installation including earthing and cross bonding must comply with the current IEE regulations and any Local Authority requirements.

The cold water feed manifold assembly comprises a pressure reducing valve with integral strainer, expansion relief and check valve, factory fitted pressure and temperature relief valve and expansion vessel. All of these components must be included in the installation. The pressure settings on these components are factory set and indicated on the top of the valve. Do not break any seals or attempt to adjust any safety valve; to do so may impair the safety of the installation and will invalidate the warranty.

It is recommended that the unit is installed according to these instructions. Under no circumstances should the expansion relief valve be installed in an inverted position as fouling of the seat caused by deposits may prevent it from operating correctly.

Safety relief valve connections should not be used for any other purpose and no valve should be fitted between the expansion relief valve and the storage cylinder.

An isolating valve must be fitted to the cold water supply to the inlet manifold.

The Zip Aquapoint is designed for use with a supply pressure up to 12 bar. For supply pressures exceeding 12 bar an additional pressure reducing valve must be fitted in the cold water supply to the unit.

## Secondary Circulation

The Zip Aquapoint is not recommended for use with secondary circulation systems.

## Discharge

The expansion relief and temperature and pressure relief valves should drain via a tundish which should be installed in a visible location and away from any electrical devices.

The discharge pipe from the tundish should terminate in a safe place where there is no risk to persons in the vicinity of the discharge, be of metal and:

- a) Be at least one pipe size larger than the nominal outlet size of the safety device unless its total equivalent hydraulic resistance exceeds that of a straight pipe 9m long. Discharge pipes between 9m and 18m equivalent resistance length should be at least 2 sizes larger than the nominal outlet size of the safety device, between 18 and 27m at least 3 sizes larger, and so on. Bends must be taken into account in calculating the flow resistance. See diagram of typical discharge pipe arrangement and table for sizing copper discharge pipe.
- b) Have a vertical section of pipe at least 300mm long, below the tundish before any elbows or bends in the pipework.
- c) Be installed with a continuous fall.
- d) Have discharges visible at both the tundish and the final point of discharge but where this is not possible or it is practically difficult there should be clear visibility at one or other of these locations. Examples of acceptable discharge arrangements are:
  1. Ideally below a fixed grating and above the water seal in a trapped gully.
  2. Downward discharges at a low level: i.e. up to 100mm above external surfaces such as car parks, hard standings, grassed areas etc. are acceptable providing that where children may play or otherwise come into contact with discharges, a wire cage or similar guard is positioned to prevent contact, whilst maintaining visibility.
  3. Discharges at high level: e.g. into metal hopper and metal down-pipe with the end of the discharge pipe clearly visible (tundish visible or not) or onto a roof capable of withstanding high temperature discharges of

water and 3m from any plastic guttering system that would collect such discharges (tundish visible).

4. Where a single pipe serves a number of discharges, such as in blocks of flats, the number served should be limited to not more than 6 systems so that any installation can be traced reasonably easily. The single common discharge pipe should be at least one pipe size larger than the largest individual discharge pipe to be connected. If unvented hot water storage systems are installed where discharges from safety devices may not be apparent e.g. in dwellings occupied by blind, infirm or disabled people, consideration should be given to the installation of an electronically operated device to warn when discharge takes place.

**Note:** The discharge will consist of scalding water and steam. Asphalt, roofing felt and non-metallic rainwater goods may be damaged by such discharges.

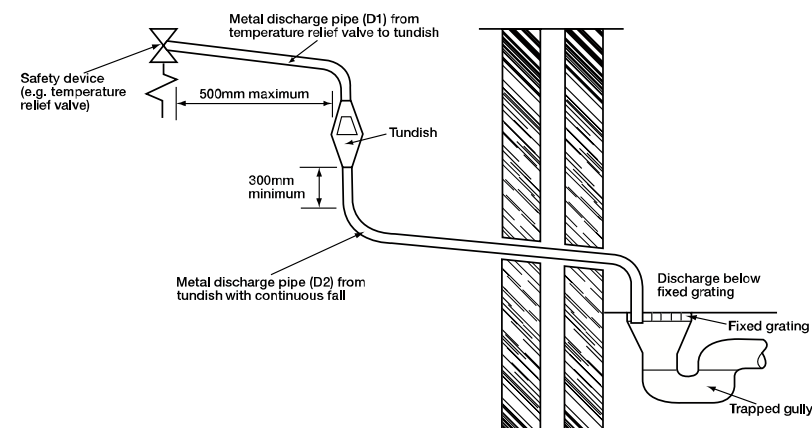

**Typical discharge pipe arrangement**  
**Sizing of copper discharge pipe 'D2' for common temperature relief valve outlet sizes**

Valve outlet size	Minimum size of discharge pipe D1	Minimum size of discharge pipe D2 from tundish	Maximum resistance allowed, expressed as a length of straight pipe (i.e. no elbows or bends)	Resistance created by each elbow or bend
G <sup>1/2</sup>	15mm	22mm	up to 9m	0.8m
		28mm	up to 18m	1.0m
		35mm	up to 27m	1.4m
G <sup>3/4</sup>	22mm	28mm	up to 9m	1.0m
		35mm	up to 18m	1.4m
		42mm	up to 27m	1.7m
G 1	28mm	35mm	up to 9m	1.4m
		42mm	up to 18m	1.7m
		54mm	up to 27m	2.3m

## Positioning

The Zip Aquapoint should be installed vertically with the electrical cover panel and water connections underneath.

The unit is designed to be wall mounted using the wall fixings supplied with the product. Ensure that the wall where the unit is to be located is sufficiently strong to support the full weight of the unit (see dimensions) and capable of accepting suitable fixings.

Position the Zip Aquapoint to allow for provision of the cold water supply, discharge fittings and pipework as well as access for future maintenance, repair of the unit or its replacement. Reasonable clearance will be required to give access to pressure controls, element assembly, draining facility, pipe connections and expansion vessel.

A gap of 250mm should be left between the top of the unit and the ceiling. A gap of 350mm should be left between the bottom of the unit and any floor or work surface.

Do not install in a location where the unit or connecting pipework can freeze.

Fix the Zip Aquapoint hot water cylinder locating bracket to the wall with suitable fixings as shown in the diagram and table of dimensions below.

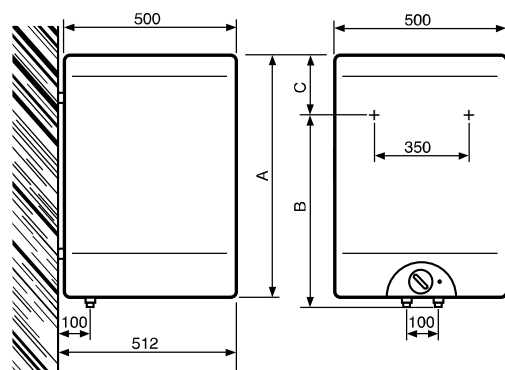

	A	B	C
<b>AP3/30</b>	525	310	240
<b>AP3/50</b>	690	470	250
<b>AP3/80</b>	950	735	245
<b>AP3/100</b>	1125	900	245

Position the Zip Aquapoint securely on the locating bracket.

The expansion vessel should be securely fitted to a suitable and convenient wall using the fittings supplied and positioned to enable its connection to the manifold assembly.

When deciding the final location of the heater consideration should be given to the safe and visible disposal of any water resulting from leaks or seepage. This is particularly relevant when the heater is located in a roof space, cupboard or any concealed location. For guidance please ring Zip Heaters on 0870 608 8888.

## Plumbing

1. The unit should be provided with a continuous cold water supply via 22mm pipework.
  2. The water connections are 1/2" BSP at the bottom of the appliance. When viewed from the front, the cold feed connection is to the right and colour coded blue, the hot outlet from the heater is to the left and colour coded red.
  3. The inlet and outlet pipes to the heater should be sealed using fibre washers. Complete the seal by applying PTFE tape to the threads, but do not over apply or extend beyond the limits of the thread as this will lessen the effectiveness of the joint.
  4. An isolating valve (not supplied) should be fitted in the cold water supply pipework to the inlet manifold assembly to enable isolation of the water supply to the unit for servicing or replacement.
  5. Fit the inlet manifold assembly to the 22mm supply pipework with the valve caps facing upwards and in the correct direction of flow as indicated by the arrows.
  6. The pressure gauge connection point on the manifold assembly should be accessible for connection of a pressure gauge if necessary.
  7. Provide suitable drainage from the Expansion relief and Temperature & Pressure Relief Valves via the tundish using 15mm copper tube. Refer to installation requirements.
  8. Connect the expansion vessel to the manifold assembly using 15mm copper tube.
  9. A balanced mains pressure cold water supply for a shower may be provided from the connection provided on the manifold assembly, otherwise this should be blanked.
- Note: This connection should not be used to supply cold taps.**
10. Flush all pipe work thoroughly before making the final connections from the cold supply to the manifold assembly to ensure that any debris is removed. Failure to do this may result in irreparable damage to the controls and will invalidate the warranty.
  11. Connect the hot water supply pipe to the outlet from the heater.
  12. Connect the discharge pipe from the tundish. Refer to Installation Requirements.

## Electrical

Switch off the mains electrical supply before removing the electrical cover panel or carrying out any work involving a live circuit or access to components that may be live.

**Do not switch on the electrical supply until the unit is full of water.**

**This appliance must be earthed.**

The electrical connection to the heating elements must conform to current IEE wiring regulations and be permanently connected to the electrical supply through a double-pole isolating switch with at least 3mm contact separation in each pole and with a minimum rating of 15A.

All internal wiring is factory mounted and should not be altered or modified.

A suitable supply cable should be fed through the grommet on the underside of the appliance, connected to the live, neutral and earth connections on the terminal block and secured with the cable clamp provided.

Check all electrical connections for security and tightness.

The appliance has a working thermostat adjustable between 25°C and 75°C. An over temperature cut-out is incorporated within the thermostat which is designed to operate at 79-84°C. Should this happen, press the reset button.

***Important:* Before resetting the over temperature cut-out or altering the thermostat setting, isolate the electrical supply to the unit before removing the electrical cover panel. Ensure that the cover panel is replaced correctly and the retaining screws fitted before re-connecting the electrical supply.**

## Commissioning

1. Check that all the requirements under "Installation Requirements" have been met
2. Check that all water and electrical connections are correct and tight
3. Check that the expansion vessel pressure is correct – refer to label on vessel for correct pressure
4. Check that the drain valve on the inlet manifold is closed
5. Open hot water taps
6. Open the cold water supply valve and permit the heater to fill
7. Leave hot taps open until all air has been purged from the system and water is flowing freely from all outlets
8. Check for leaks and rectify as necessary
9. Check the operation of the T&P relief valve
10. Manually operate Expansion Relief Valve to ensure free water flow

through the discharge pipe by turning the knob to the left and holding in the open position

11. Set the thermostat(s) to the desired temperature setting. The 'E' position with a water temperature of approx. 55°C is recommended for economical operation while minimising lime-scale deposits and thermal losses
12. Switch on the electrical supply to the unit. The pilot light will illuminate to indicate that the elements are operating
13. During the heating cycle no water should escape to waste from either the expansion relief or T&P relief valves
14. Allow the heater to reach the selected temperature when the pilot light will extinguish. Check the water temperature and re-check water connections adjusting as necessary
15. Pass these instructions to the person responsible for the building management

## Maintenance

### Precautions

1. The Zip Aquapoint is an unvented electric water heater and a competent person, familiar with unvented systems, should carry out all servicing and maintenance
2. Do not remove the electrical cover panel whilst the unit is connected to the electrical supply
3. Do not reset the over temperature cut-out until the cause of its operation has been diagnosed and necessary repairs have been undertaken
4. Do not use the water heater if it is suspected of being frozen. Switch off the electrical supply if water ceases to flow and do not switch on again until a competent person has checked that it is safe to do so
5. The heater should be visually inspected regularly. This is particularly important if the heater is located in a cupboard, roof space or any other concealed location. If there is any sign of leaks or seepage the heater should be isolated from the water supply and switched off from the electrical supply until a competent person has investigated the cause
6. Do not block or restrict the discharge from any safety valve
7. Do not tamper with any safety valve
8. If water discharges from any safety valve switch off the electrical supply to the unit, isolate the water supply and contact a competent person familiar with unvented systems
9. Please note that lime-scale deposits form more readily at higher temperatures. Damage or failures caused by the formation of lime-scale

are specifically excluded under the terms of the warranty. To reduce lime-scale formation to a minimum the unit should always be operated at the lowest convenient temperature. The 'E' temperature setting is recommended

10. If the unit has been commissioned and is to be unused for more than two weeks with the power supply still connected the thermostat should be set to '\*' to maintain a temperature of approx. 9°C and protect the unit from freezing. **Note: this protection does not extend to connecting pipework.** It is recommended that the cold supply is turned off and several litres of water drawn off through a hot tap. **Note: The cold supply must be re-opened prior to use.** If power has been disconnected it is recommended that the unit is drained (see draining)
11. The Zip Aquapoint is fitted with a sacrificial anode to provide additional protection against corrosion. Gradual erosion of the sacrificial anode will occur depending upon local conditions which in extreme cases may cause rapid erosion of the anode resulting in particles being deposited as a residue. The Aquapoint should not, therefore, be used in applications where water quality is critical. Regular preventive maintenance inspections are vital to achieve optimum performance and durability of the appliance. The condition of the anode should be checked regularly by an authorised Zip service provider as part of the preventive maintenance programme.

## Schedule

It is recommended that all key components of the heater should be inspected on a regular basis, no greater than twelve monthly intervals, for continued safe and efficient operation. The inspection should be carried out by a competent person familiar with unvented systems and the components to be inspected should include the following:

1. Expansion relief valve. Check for correct operation
2. T&P relief valve. Check for correct operation
3. Check expansion vessel pressure – refer to label on vessel for correct pressure
4. Inspect integral line strainer and clean as necessary
5. Check that the discharge pipework is free of any obstructions
6. Check that all electrical connections are tight
7. Check condition of the sacrificial anode by disconnecting the wire between the anode and vessel and verifying that the current between anode and vessel exceeds 0.1mA ensuring that the wire is re-connected afterwards. If the current between anode and vessel does not exceed 0.1mA the anode should be checked visually and replaced if necessary

## Fault Finding

**Note: All servicing and repairs must be undertaken by a competent person, familiar with unvented systems.**

Fault	Possible Cause	Solution
Over temperature cut-out operates	The thermostat has failed  The thermostat is set at too high a temperature	Reset. If the cut-out operates again isolate the unit and contact the installer. <i>Note: Isolate the electrical supply before removing the electrical cover panel and ensure that the panel is correctly replaced and secured before reconnecting</i>
Regular, intermittent water discharge from tundish	Loss of pressure from the expansion vessel  Thermostat failure	Isolate the heating system and the mains cold water supply. Partly drain the unit. Recharge the expansion vessel to the specified pressure and re-commission.  Isolate the heating system and check thermal controls when discharge ceases. Replace thermostat if faulty.
Continuous water discharge from the tundish	Pressure reducing valve not operating correctly  P&T relief valve not operating correctly  Expansion relief valve not operating correctly	Check with pressure gauge and replace as necessary  Check and replace if faulty  Check and replace if faulty
No water flow from hot taps	Cold water mains supply isolated  Integral line strainer in pressure reducing valve has become blocked  Pressure reducing valve incorrectly fitted	Restore mains supply to the heater  Check and clean as necessary  Refit correctly with arrows in direction of flow
Water from hot taps is cold	Power supply not switched on  Over temperature cut-out has operated  Faulty element  Thermostat failure	Check and switch on  See fault "Over temperature cut-out operates" above  Check and replace as necessary  Check and replace as necessary

## Draining

To drain the unit:

1. Isolate the electrical supply
2. Isolate the mains cold water supply to the unit
3. Open a hot water tap
4. Remove the plug from the drain point on the heater
5. Connect a suitable hose to the drain point to allow the contents to be drained safely
6. Open the drain valve and allow the unit to drain

## De-Installation

To de-install the heater:

1. Switch off and disconnect the electrical supply
2. Close the mains water supply isolating valve
3. Drain the heater as described in "Draining"
4. Disconnect the cold water inlet connection from the manifold assembly
5. Disconnect the hot water supply pipe from the heater outlet
6. Remove the heater

## Warranty

The Zip appliance you have chosen is precision-built from the finest materials available and should give many years of trouble free service.

Certain warranties may be implied by law into your contract with Zip. The warranty provided below is additional to these implied warranties and nothing set out below shall limit your statutory rights or rights at law.

Zip Heaters (UK) Ltd warrants that, should any part fail within 12 calendar months of installation, that part will be repaired or replaced free of charge by Zip or its Distributor or Service Provider, except as set out below, provided the appliance is installed and used strictly in accordance with the instructions supplied, and that failure is not due to accident, misuse, abuse, unsuitable water conditions, or to any alteration, modification or repair by any party not expressly nominated by Zip.

No costs are payable by the customer other than any mileage or travelling-time charges incurred by a Zip Service Provider or the cost of removal, cartage and re-installation of any component of the appliance if it needs to be returned for repair to Zip or its Distributor.

This warranty does not cover damage resulting from non-operation of the appliance or consequential damage to any other goods, furnishings or property. Zip does not exclude, restrict or modify any liability that cannot be excluded, restricted or modified or which cannot, except to a limited extent, be excluded, restricted or modified as between the owner or user and Zip under the laws applicable.

Furthermore, this warranty does not displace any statutory warranty, but, to the extent to which Zip is entitled to do so, the liability of Zip under any statutory warranty will be limited at Zip's option to the replacement of the appliance or supply of equivalent appliance, the payment of the cost of replacing the appliance or acquiring an equivalent appliance, or the payment of the cost of having the appliance repaired or the repair of the appliance.

Zip Heaters (UK) Ltd  
14 Bertie Ward Way  
Dereham, Norfolk NR19 1TE  
Telephone 0870 608 8888  
Telefax 01362 692448  
[www.zipheaters.co.uk](http://www.zipheaters.co.uk)