

Zip HydroTap® All-In-One

Filtered Boiling and Chilled water plus Hot and Cold water for kitchens and tea rooms.

This Installation Instruction covers the following HydroTap models:

Affix Model Number Label Here
89650UK



Check List

Installation Checklist:

- A. Read the instructions.
- B. Note: Not all fittings are supplied with the appliance kit. Isolation valves are not supplied.
- C. Check the water pressure to determine if you require a pressure reduction valve or a flow restrictor added or removed from the kit.
- D. Check the water quality to determine if extra filtration will be required.
- E. Check the appliance rating plate and ensure correct power is available for the appliance.
- F. Check the underbench cupboard supporting the appliance is adequate for the total weight of the appliance, when full of water.

Before Commissioning:

- 1. Check the unit has been secured correctly.
- 2. Flush the supply line before connecting.
- 3. Check all plumbing fittings have been tightened.
- 4. Ensure the outlet and vent pipes are positioned to drain correctly.
- 5. For undersink units ensure there is adequate ventilation.
- 6. Check all tubes from the undersink unit to the tap, have a constant rise and there are no 'S' traps or kinks in the hoses.
- 7. Check all electrical connections are correct and there are no loose wires.

Commission:

- 8. Turn on the water and check for leaks.
- 9. Flush the tap for 3 - 5 minutes.
- 10. Turn on the power.
- 11. Allow sufficient time for the unit to heat up, before using.

Contents

Check List	2
Contents	3
Product Description	4
Read These Warnings First	4 - 5
Installation Requirements	5 - 6
Models Covered by These Instructions.	6
Special Tools Required	6
Installation Procedure	6 - 11
Operating the Mixer Tap	11
Mains version connections (diagrams)	12 - 13
Vented version connections (diagrams)	14 - 15
External Filter Replacement	16
Internal Filter Replacement	16 - 17
Operating the HydroTap.	18
Child Safety Lock.	18
Setting the Energy Saver Timer	19 - 20
Auxiliary Fan Attachment.	21
Boiling Water Isolation	21
Setting Boiling and Chilled dispensing Times.	21
Trouble Shooting	22
Cleaning	23
End of Life Disposal.	23

NOTE:

Read all instructions and precautions before proceeding. If in doubt, or need further guidance, please call Zip on 0800 077 8302.

Please leave these instructions with the end user after installation

This unit must be installed in accordance with water supply byelaws, current IEE regulations and relevant local authority byelaws.

Product Description

Hydrotap All-In-One series are able to supply Boiling and Chilled water as well as Hot and Cold water, all from the same tap.

The 'AV' series have their Boiling / Chilled / Hot outlets connected to the undersink (open vented) unit, Cold outlet connected to the mains.

The 'A' series have their Boiling / Chilled outlets connected to the undersink (open vented) unit and their Hot and Cold mixer outlets are connected to external (Mains) Hot water and Cold water supplies.

The estimated temperature ranges will be:

Boiling water: 68°C - 98°C

Mixed water: From ambient up to approximately 50°C

Cold water: Ambient.

Chilled water: 5°C - 10°C

Read These Warnings First



The power point must be located within reach of its cable (length 3m). The appliance must be positioned so that the power point is accessible.



Hydrotap undersink assembly.
The appliance must be placed in a horizontal position, as shown above.

Safety

This appliance is not intended for use by persons (Including Children) with reduced physical, sensory or mental capabilities, or lack of experience and knowledge, unless they have been given supervision or instruction concerning use of the appliance by a person responsible for their safety.

Children should be supervised to ensure they do not play with the appliance

Refrigerant

The HydroTap Chilling unit contains 134A refrigerant under pressure. No part of the unit should be exposed to a naked flame. Maintenance of the refrigeration unit must be carried out by an accredited service provider or qualified refrigeration mechanic.

Qualifications

If the power cable is damaged it must be repaired only by a qualified technician. To avoid hazards, all installation procedures must be carried out by a suitably qualified tradesperson. The power cable and power outlet must be in a safe visible position for connection.

Venting

Sometimes steam and / or boiling water may discharge through a vent outlet at the mouth of the tap. Ensure the tap body is located so the tap outlet safely drains into the sink bowl area.

NOTE: On startup, the controls take the system through a calibration process which causes the unit to over-boil for a period of 90 secs. Once this mode is completed the system reverts back to normal operation.

Lifting

Take care when lifting the HydroTap undersink unit. Some units may exceed safe lifting limits. If you feel this is beyond your personal capabilities, please seek assistance with the lift. The weights of the units are marked on the packaging and given in the table under the heading "Installation Requirements". Do not lift the unit by the doors.

Airflow

The ambient temperatures this unit should operate within are 5°C - 35°C. Proper air circulation must be provided. The system will operate satisfactorily only if the recommended air gaps are provided, these are 65mm min rear clearance and 50mm side clearance. An air vent is provided with each unit for high usage applications, this must be installed in the top half of the cupboard door as a matter of course. An accessory exhaust fan kit is available and should be used to ensure adequate

Read These Warnings First (continued)

Note:

Always ensure the tubes are shortened so that any excess is removed and their route is the most direct line between the tap assembly and the HydroTap unit.

Do not allow the tubes to sag or droop so water is trapped within the hoses. Always maintain a constant fall

Positioning of the tap assembly must be within the following parameters:

The height between the base of the Hydrotap unit and the base of the Tap assembly cannot be greater than 900mm.

ventilation. Auxiliary fan should always be fitted when supplied with large units. Make sure that the ventilation grilles of the undersink unit are not obstructed. Included in the installation pack are adhesive backed silicon buffers. If air vents are not installed in the cupboards housing the HydroTap, the buffers must be placed on the inside edge of the cupboard door to create a slight gap ensuring a minimum airflow. Failure to do this may cause the HydroTap to overheat and operate inefficiently.

Minimum Pressure warning:

All AV models require a minimum cold water supply pressure of 2bar (200 kPa) and a maximum of 7bar (700 kPa).

All A models require a minimum cold and hot water supply pressure of 0.7 bar (70kpa) and a maximum working pressure of 7 bar (700 kPa).

Filter Control

The HydroTap filter control is preset to 6000 Litres to provide trouble-free flow and operation in most installations. Local water quality conditions may require an alteration to this capacity. In areas where the water has a high concentration of sediment, the preset litre capacity may be shortened to avoid poor flow, taste or odour situations. In areas where the water quality is above average, lengthening the preset capacity may be desirable, but not essential. If any of these changes is needed, follow the instructions on page 16/17 or contact your Service Provider.

Frost Protection

If this appliance is located where the ambient air temperature could fall below 5°C when the heater is not in use, do not turn off the appliance electrically. This safeguard does not offer the same protection to the connecting pipework and fittings.

Altitude

The HydroTap is equipped with a self-calibrating program which caters for altitude adjustment.

Installation Environment Considerations

This unit is intended for indoor use only and should never be installed outdoors or exposed to the elements of nature. This unit must not be positioned in an area that may be cleaned by a water jet. This unit must not be cleaned by a water jet.

NOTE:

HydroTaps are designed to operate within 1°C to 2°C of boiling point and at 5°C to 10°C for chilled drinking water.

Installation Requirements



Before installing ensure that the following have been provided at the installation site:

- Sufficient space in the cupboard to install the undersink unit in accordance with these Installation Instructions. A table of dimensions is given on page 6.

NOTE: Add 65mm to the Depth of the undersink unit to allow for Water and Electrical connections and ventilation.

- A water supply connection with isolating valve inside the cupboard within reach of the 750 mm flexible connection and positioned so that the connection point and the isolating valve will not be obstructed when the undersink unit is installed.
- Power supply of 220-240 Volt AC, for connection to the unit via a 13 amp fused spur.
- This switch must provide all-pole disconnection with a contact separation of at least 3mm, installed in accordance with wiring regulations.

Installation Requirements (continued)

- For AV models, cold water supply with a minimum working pressure of 2 bar (200 kPa) and a maximum working pressure of 7 bar (700 kPa) connected via an isolation valve. For all A models, cold and hot water supply with a minimum working pressure of 0.7 bar (70kpa) and a maximum working pressure of 7 bar (700 kPa). If pressure is likely to exceed 7 bar, install a 5 bar (500 kPa) Pressure Limiting Valve.
- The fitting of an air flow vent, cut into the top half of the cupboard door concealing the HydroTap requires a cut size of approximately 100mm circular, to provide adequate warm air displacement. In installations where high volume draw-off will occur, the fitting of the accessory exhaust fan is essential.
- Accessory exhaust fan must be fitted when supplied with 150/175 and 200/175+ models. Buffers must be fitted to cupboard door.

Important:

Do not proceed with the installation if these requirements are not met.

Commercial Models Covered by These Instructions

AV	160	125
Model	Cups of Boiling Water per Hour	Glasses of Chilled Water per Hour

These Installation Instructions cover the A and AV HydroTap range. Use the chart on the left to identify the model you are using:

Commercial Models:

A = Boiling / Chilled and Hot / Cold. (Mains)

AV = Boiling / Chilled and Hot / Cold. (Vented)

Boiling Water Capacity:

160 = 160 cups in one hour** 200 = 200 cups in one hour**

** Capacity will be reduced by the volume of water used when operating the mixer tap.

Chilled Water Capacity:

125 = 125 glasses in one hour 175 = 175 glasses in one hour

Note: The **Cup** measurement = 167mls, the **Glass** measurement = 200mls.

Model	Height mm (inch)	Depth mm (inch)	Width mm (inch)	Weight empty kg's lbs	Weight full kg's lbs
BC 60/85A	340 (13.3)	430 (16.9)	430 (16.9)	28	34.5
BC100/125A, BC160/125+A BC100/125AV, BC160/125+AV	340 (13.3)	430 (16.9)	430 (16.9)	28 (61.7)	35 (77.1)
BC150/175A, BC200/175+A BC150/175AV, BC200/175+AV	395 (15.5)	470(18.5)	500 (19.6)	29.5 (65)	38 (83.7)

Special Tools Required

In addition to normal tools, the following will be required:

- 50mm diameter sheet metal hole punch for sink tops. (not supplied)
- 50mm diameter hole saw for timber bench tops. (not supplied)
- Nut runner tube spanner (supplied) for fixing tap assembly.

Installation Procedure

Step A - Installing the All-in-One tap (see P12-15)

1. Make sure that the tap location will allow the nozzle to drain into the sink.

NOTE 1: The tap assembly must not be positioned more than 900mm above the HydroTap unit.

Failure to do this may result in poor water delivery.

Installation Procedure (continued)

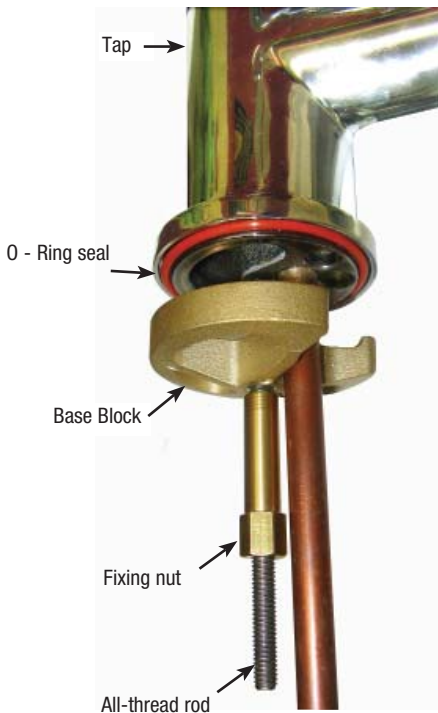

NOTE :

New hose sets supplied with the unit should be used. Do not use old hose sets.

2. Cut a 50mm hole in the bench / sink top.
3. Ensure the silicon O-Ring remains in place as this is the moisture seal against the bench / sink top. **A light smearing of silicon sealant on the O-Ring will ensure a watertight fit.**
4. Pass all hoses through the 50mm hole and carefully locate the Head Assembly on the bench / sink top.
5. From the underside of the bench / sink, mount the 'base block' by feeding each of the tubes and electrical cable evenly in between the legs of the 'base block'. Slide it up to meet the 'all thread rod', and pass the 'all thread rod' through the centre of the 'base block'.
6. Hold the 'all thread' steady and fit the 10mm 'fixing nut' to the 'all thread' using the tube spanner supplied in the kit. Check the Tap Head position before securing it tightly against the bench / sink top.

NOTE 2: Under no circumstances should the Tap be twisted after the installation is complete.

Step B - Installing the undersink unit

SPECIAL NOTE: The HydroTap undersink units are heavy, take note of the weights listed in the table on page 6. If you think you cannot lift the unit safely, get help and avoid possible injury.

Before positioning the heater connect the braided water inlet hose (supplied) to the cold water tee piece (see Pages 12-15). Flush the hose prior to connecting to the cold water inlet at the rear of the unit.

Position the HydroTap undersink unit as close as possible to directly beneath the All-in-One tap head.

The connection tubes supplied with the tap head assembly CANNOT be lengthened.

Leave at least a 50 mm air-gap without obstruction on each side of the unit and 65mm at the rear

Step C - Connecting the All-in-One tap outlet

Note:

Included in the installation pack are adhesive backed silicon buffers. If air vents are not installed in the cupboards housing the HydroTap, the buffers must be placed on the inside edge of the cupboard door to create a slight gap ensuring a minimum airflow. Failure to do this may cause the HydroTap to overheat and operate inefficiently.

Model: Vented

Connect the 3 braided hoses to the rear of the undersink unit as shown in pages 14 -15.

Measure and trim the blue silicon tube and connect it to the chilled water outlet located on the top front, right hand side of the undersink unit. Use spring clamps provided to secure the hose.

Measure and trim the red silicon tube and connect it to the boiling water outlet located on the top centre, right hand side of the undersink unit. Use spring clamps provided to secure the hose.

Measure and trim the clear silicon tube and connect it to the vent outlet located on the top centre, left hand side the top of the undersink unit. Use spring clamps provided to secure the hose.

Installation Procedure (continued)

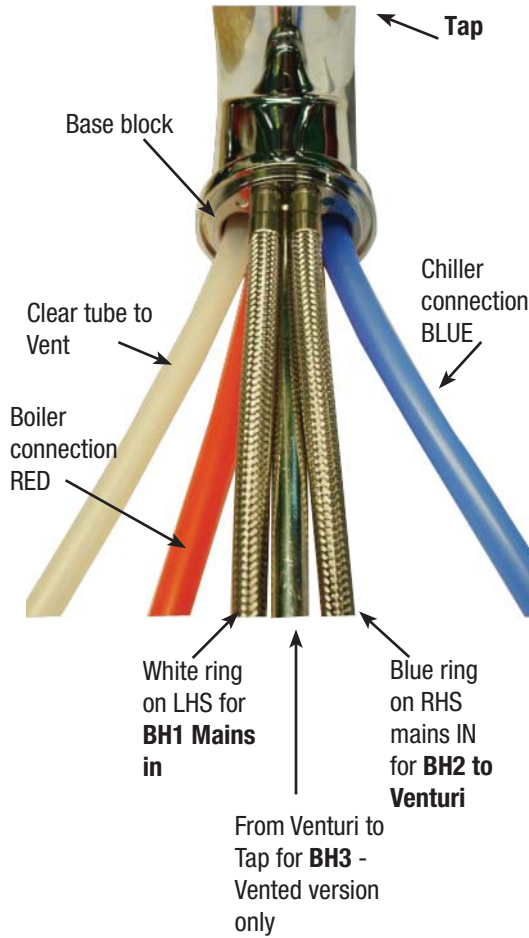

NOTE: All tubes must have a continuous fall back to the undersink unit.

Connect the tap USB connector to the USB lead on the undersink unit. Orient the USB plug carefully and connect, do not force the plug. Once connected, fix the cable to the wall, ensure it is away from any possible water splashes and is off the floor.

NOTE: When trimming any silicon tubes trim to minimum length, do not loop any excess or allow kinking of the tubes. When connecting, slide the tube over the pipe at least 25mm. There are black plastic clamps provided on the boiling and chilled hoses to choke the flow if required. Only choke the flow if it is excessively strong.

Model: NON Vented.

Connect the two braided hoses to the Hot and Cold water supply, as shown in pages 12-13.

Measure and trim the red marked tube and connect it to the boiling water outlet on the top of the undersink unit. Use spring clamps provided to secure the hose.

Measure and trim the blue marked tube and connect it to the chilled water outlet on the top of the undersink unit. Use spring clamps provided to secure the hose.

Measure and trim the unmarked tube and connect it to the vent outlet on the top of the undersink unit. Use spring clamps provided to secure the hose.

NOTE: All tubes must have a continuous fall back to the undersink unit.

Connect the tap USB connector to the USB lead on the undersink unit. Orient the USB plug carefully and connect, do not force the plug. Once connected, fix the cable to the wall, ensure it is away from any possible water splashes and is off the floor. Fasten the tap body to the sink using the bolt & plate system provided.

The following instruction is CRITICAL:

Adjust both cupboard door hinges and attach the supplied rubber door buffers to the doors to create a 4 mm air-gap between the doors and the cupboard. This is the minimum ventilation requirement for low usage installations.

Proper air circulation must be provided for all Boiling and Chilled models. The system will operate correctly only if the recommended air gaps are achieved during installation. A ventilation hole measuring 100mm must be cut into the top half of the cupboard door to accommodate the air vent provided. Make sure that the undersink unit ventilation grilles are not obstructed in any way.

Step D - Connecting the water supply

To prevent sediment from entering the HydroTap at connection, flush water through the supply line thoroughly before connection to the HydroTap. Open the access door and check that the filter is in place and secure. Connect the water supply to the undersink unit using the attached flexible hose. Turn on water and check for leaks. If no leaks are evident turn the power on.

Step E - Connecting an external filter.

(Not supplied as standard equipment).

To combat the build up of lime scale, a high performance external filter kit may be ordered from your Zip service provider.



Rear panel with external filter fittings

Installation Procedure (continued)

REMOVE THIS PANEL TO ACCESS EXTERNAL FILTER BYPASS VALVE.

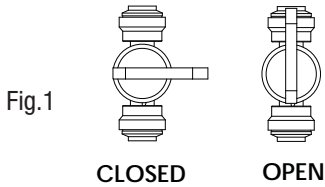

Fig.1

WHEN AN EXTERNAL FILTER IS INSTALLED TO SUPPLY THE HOT TANK, TURN THE VALVE TO THE CLOSED POSITION.

NOTE:

- When fitted, the external filter will supply filtered water only for the Hot tank. The internal filter will continue to supply filtered water for the cold tank.
- The external filter may require the inlet water pressure to be regulated to lower than 6 bar. In this case a 3.5 bar (350 kPa) Pressure Reduction Valve will be required.
- The rear of the unit is fitted with, 1/4" John Guest, inlet and outlet fittings, specifically for the Zip high performance filter kit.
- These instructions must be read in conjunction with the filter fitting instructions supplied with the high performance filter kit.
- The filter assembly must be located close to the appliance with sufficient space for service access. Consult the instructions supplied with the filter kit.

To fit the external filter kit:

- Access the filter bypass valve, by removing the white plastic plug, located on the Left hand side of the undersink unit (see Fig.5)
- Using a suitable set of pliers, close the filter bypass valve as instructed in Figure 1.
- Remove the Inlet and Outlet plugs from the John Guest fittings as shown in Figures 2 ; 3 and 4.
- After suitably mounting the filter assembly to an adjacent surface, measure and trim the filter inlet and filter outlet tubes.
- Fit the tubes to their respective inlets and outlets, checking to ensure the flow of water corresponds to the direction indicated by the arrow on the filter head and by the instructions listed on the rear panel of the under sink unit.
- Check the lower left hand John Guest fitting is the 'Inlet from the external filter', and the right hand John Guest fitting is the 'Outlet to the external filter'.
- Refit the white plastic plug and relocate the undersink unit, ensuring all air gaps and clearances are maintained. (see P4 Airflow details).
- Activate the filter programme within the service mode.

After Testing and Commissioning (Step F)

- Set the external filter life - Max 3000 Litres
- Set external filter use (No need to flush the external filter)
- Check all connections for leaks



Fig.2

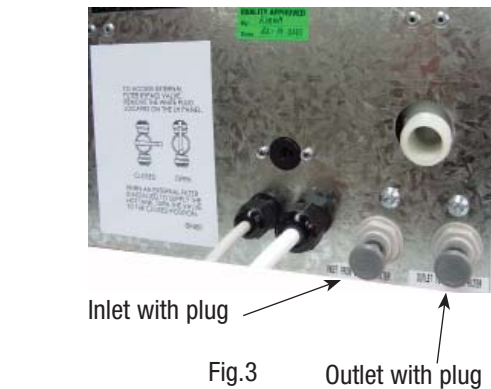
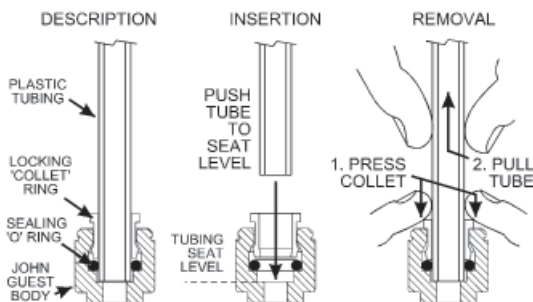

Fig.3



John Guest fittings: Insertion and removal

Fig.4

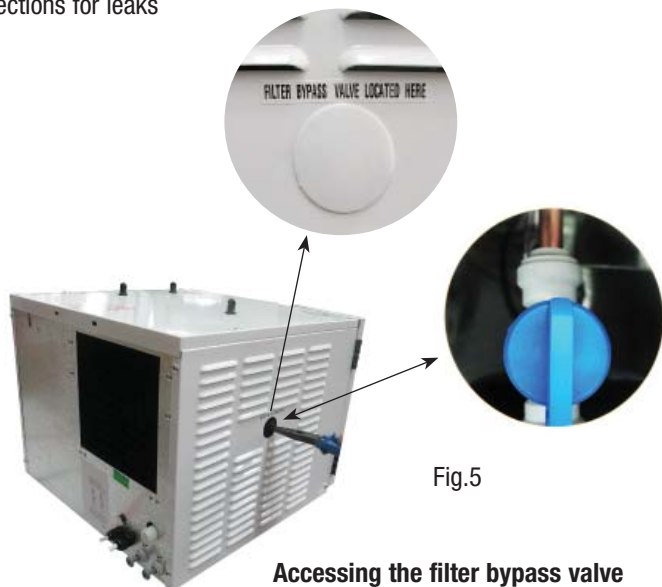

Fig.5

Accessing the filter bypass valve

Installation Procedure (continued)

Step F- Testing and commissioning



HydroTap connections for Undersink unit

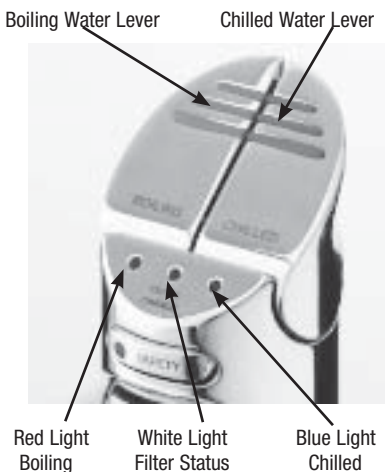
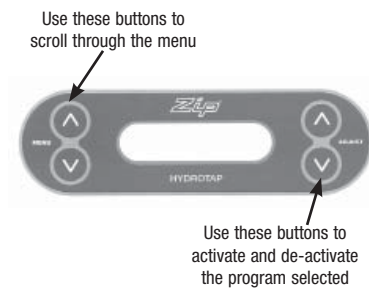

Filter Flush Mode The display screen will show which model you have.

Have a bucket or similar container (not supplied) at the ready to hold a quantity of water that is ejected while the Filter Flush Mode is in operation. Open the filter access door on the front of the HydroTap and the filter cartridge will be exposed. Located to the rear RHS of the cartridge is a fixed flush line, approx 600mm long and the flush line stop cock. Place the free end of the flush line into the bucket or container.

Turn "ON" both water and electricity supplies and open the flush line stop cock. The display will show Filter Flush Mode. To activate press adjust \wedge . Run at least 7.5 Litres of water through to activate the filter membrane. Press the adjust \wedge button again to stop the Filter Flush Mode. **Turn OFF the Filter Flush stop cock and re-locate the tube and stop cock in the filter compartment.** Turning OFF the Filter Flush Mode puts the HydroTap into calibration mode. Press adjust \wedge to start calibration. The element will now cycle On and heat the water to 95°C maintaining it at that temperature for a short stabilization period.

Once stabilized, the element will cycle On, bring the water to boiling point and hold it there for a short period.

The unit now carries out a self calibration function to ensure correct temperatures are maintained. During this period the Red LED on the Tap Head assembly flashes slowly until the calibration function is complete.

Once this step is complete (approx 5 minutes) the unit will default to normal operation.

When starting, both Boiling and Chilled cycles activate simultaneously after calibration has taken place, the descriptions below indicate what happens during each cycle.

Boiling

The unit is now running in normal operating mode. The Red LED will flash until usable temperature is reached.

Before using the HydroTap wait 5 minutes after this point to allow adequate fill time. The unit is now ready for use. Test water delivery from the tap and check for appropriate temperatures. Use cable clips to tidy and secure wiring before connecting power.

Chilled

When water and power is turned On, the Blue LED flashes slowly on the Tap Head assembly. The compressor activates and water begins to fill the chiller tank at the prescribed rate. When the water is chilled to 12°C the Blue LED on the Tap Head assembly stops flashing and stays illuminated. The compressor continues to chill down to 5° when it will cycle Off.

Ensure that the clock matches your local time. If not refer to page 19 . If Energy Saver Settings are required, the instructions for installing these are described on page 19 and 20 "Setting the Energy Saver Timer".

Step G - Temperature set point adjustment

(Not normally required)

Temperature and Water level screen: (Service Default Screen)

To access this default screen, on the right hand side of the screen, press the 'A' adjust buttons together until the screen changes to Service Mode, it will show the following:

Installation Procedure (continued)



NOTE: The temperatures shown are actual, not the set temperatures. To revert back to the Normal Operation screen, press the adjust buttons together again until screen changes.

→ Press the Menu plus button, **once**, to enter the **Hot Temperature Adjustment Screen:**

Here you can adjust the Hot temperature set point by pressing the **A** adjust \wedge or \vee buttons. The Hot temperature set point can be raised or lowered in 0.5°C increments between 68° - 100°C. **Note:** the Maximum setting of 100°C is not recommended for normal use. Do not raise temperature above 98.5°C without consulting Zip first to discuss the service issue.

→ Press the Menu minus button, **once**, to return to **the service default screen:**

To change the service default screen back to Normal Operation, press the adjust buttons together until the screen changes back.



Caution must be observed when changing any settings within the Service Menu as changes may affect the normal operation of the unit.

Operating the Mixer tap

The Mixer tap is operated as a conventional 'Flick Mixer'

Lifting the handle up will decrease the flow rate and lowering the handle will increase the flow rate. Lift the handle all the way up to turn the tap off.

When the handle is moved to the left, the temperature is decreased and when moved to the right the temperature is increased. The final temperature will be dependant on the temperature of the incoming cold water.

The spout may be swivelled, left or right, for convenience

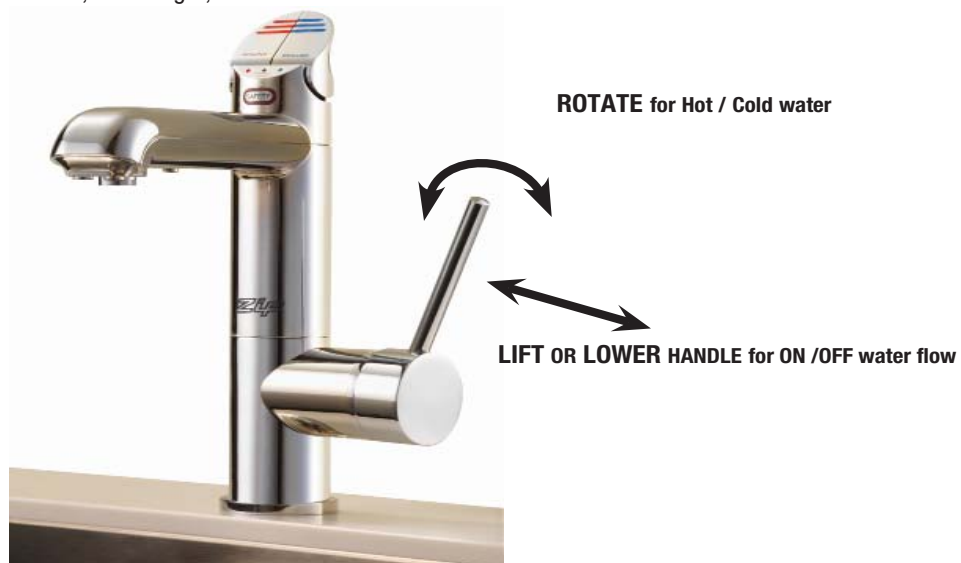

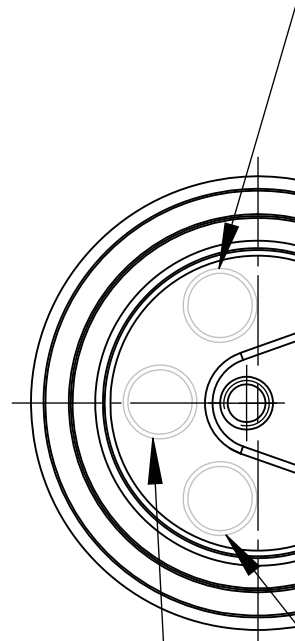
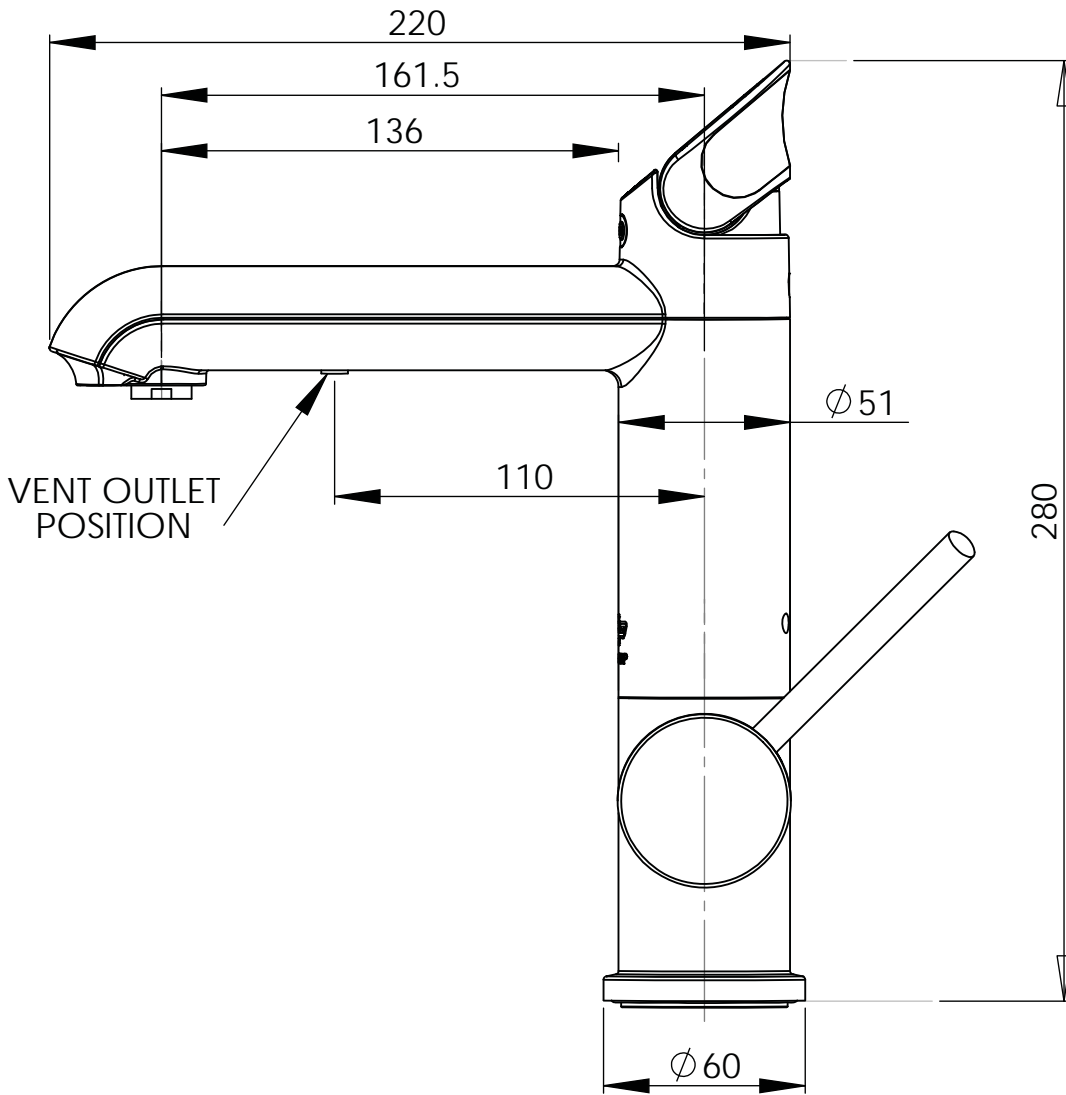

NOTE:
 IF THE FLOW RATE IS TOO FAST, CUT THE RED SILICONE TUBE 75mm MINIMUM FROM THE BOTTOM OF THE BASE OF THE ALL-IN-ONE TAP. INSERT THE TEFLON RESTRICTOR ABOUT 20mm INTO THE UPPER SEGMENT OF THE RED SILICONE TUBE WHICH CONNECTS TO THE TAP. INSERT THE BLACK PLASTIC OUTLET BUSH BETWEEN THE TWO PIECES OF RED SILICONE TUBES THAT WAS CUT.

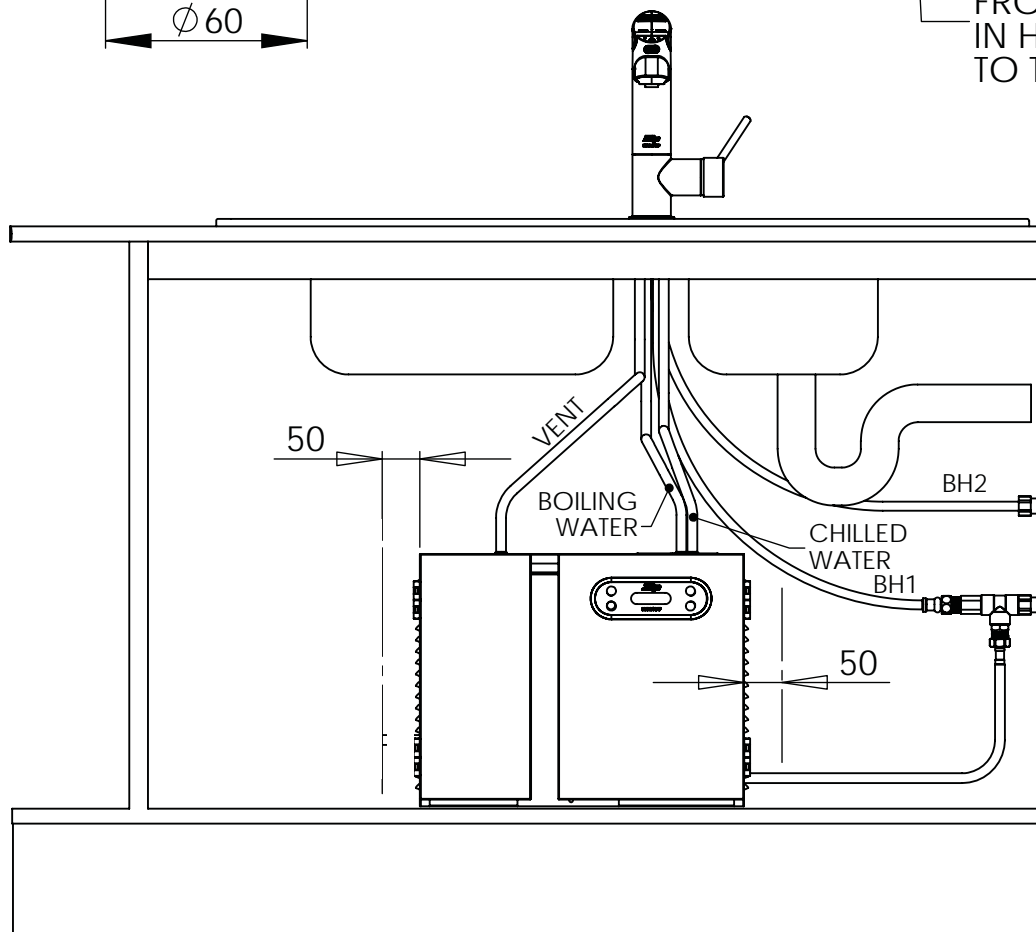

ALL IN ONE TAP-MAINS VERSION

SILICONE HOSE FROM BOILING WATER TANK IN HYDROTAP UNIT TO TAP

BRAIDED HOSE BH1 FROM MAINS WATER SUPPLY TO TAP

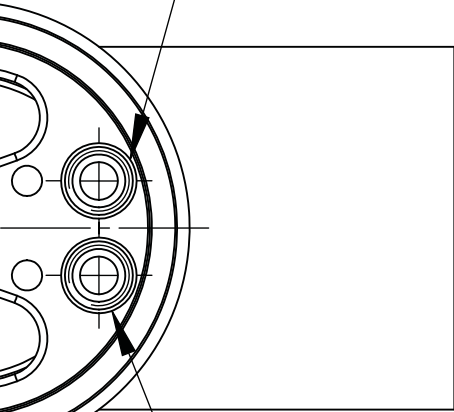

BRAIDED HOSE BH2 FROM DOMESTIC HOT WATER SUPPLY TO TAP

SILICONE HOSE FROM CHILLED WATER TANK IN HYDROTAP UNIT TO TAP

SILICONE HOSE FROM STEAM VENT IN HYDROTAP UNIT TO TAP

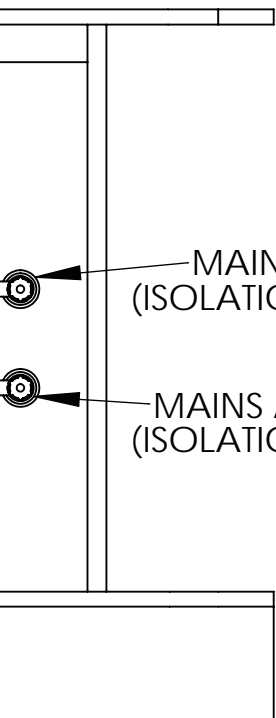

MAINS HOT WATER SUPPLY (ISOLATION VALVE NOT SUPPLIED)

MAINS AMBIENT WATER SUPPLY (ISOLATION VALVE NOT SUPPLIED)

BENCHTOP

CABINET DOOR

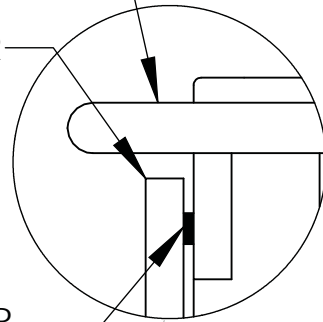

4mm BUFFER PAD TO ENSURE VENTILATION GAP

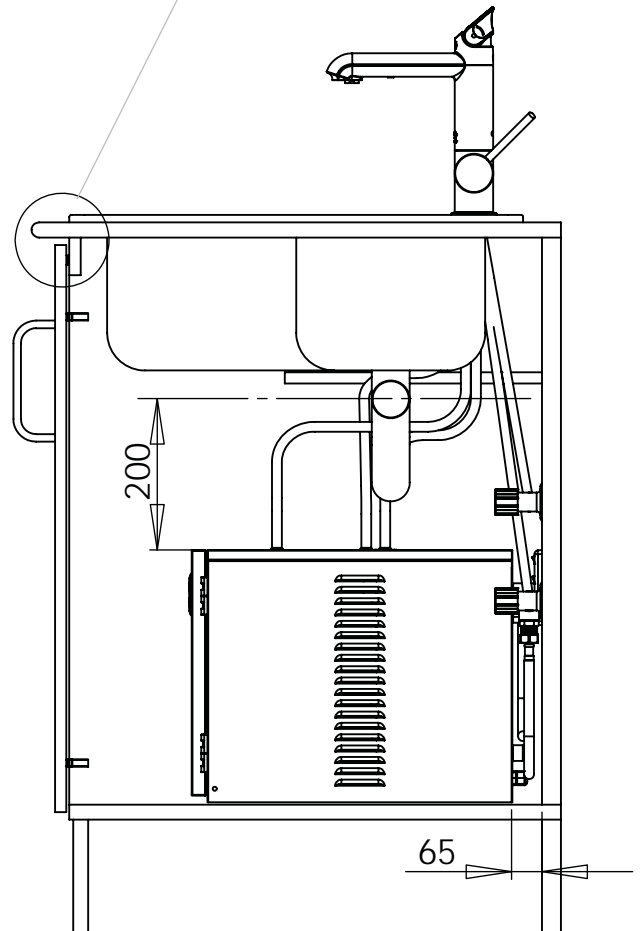

SILICONE HOSE FROM BOILING WATER TANK IN HYDROTAP UNIT TO TAP (Red)

BRAIDED HOSE BH1 FROM MAINS WATER SUPPLY TO TAP (White Ring)

SILICONE HOSE FROM STEAM VENT IN H/TAP UNIT (Clear)

BRAIDED HOSE BH2 FROM ALL-IN-ONE TAP TO VENTURI (Blue Ring)

SILICONE HOSE FROM CHILLED WATER TANK IN HYDROTAP UNIT TO TAP (Blue)

BRAIDED HOSE BH3 FROM VENTURI TO TAP

MAIN SUPP

BH2



NOTE:

IF THE FLOW RATE IS TOO FAST, CUT THE RED SILICONE TUBE 75mm MINIMUM FROM THE BOTTOM OF THE BASE OF THE ALL-IN-ONE TAP. INSERT THE TEFLON RESTRICTOR ABOUT 20mm INTO THE UPPER SEGMENT OF THE RED SILICON TUBE WHICH CONNECTS TO THE TAP. INSERT THE BLACK PLASTIC OUTLET BUSH BETWEEN THE TWO PIECES OF RED SILICON TUBES THAT WAS CUT.

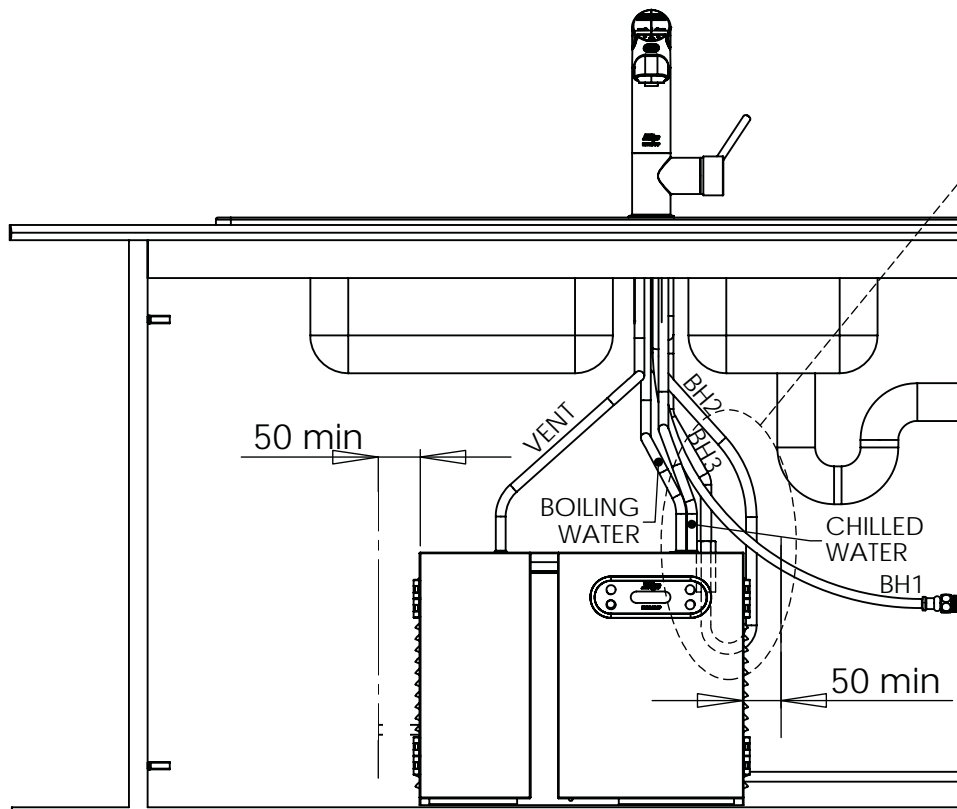

ALL IN ONE TAP-VENTED VERSION

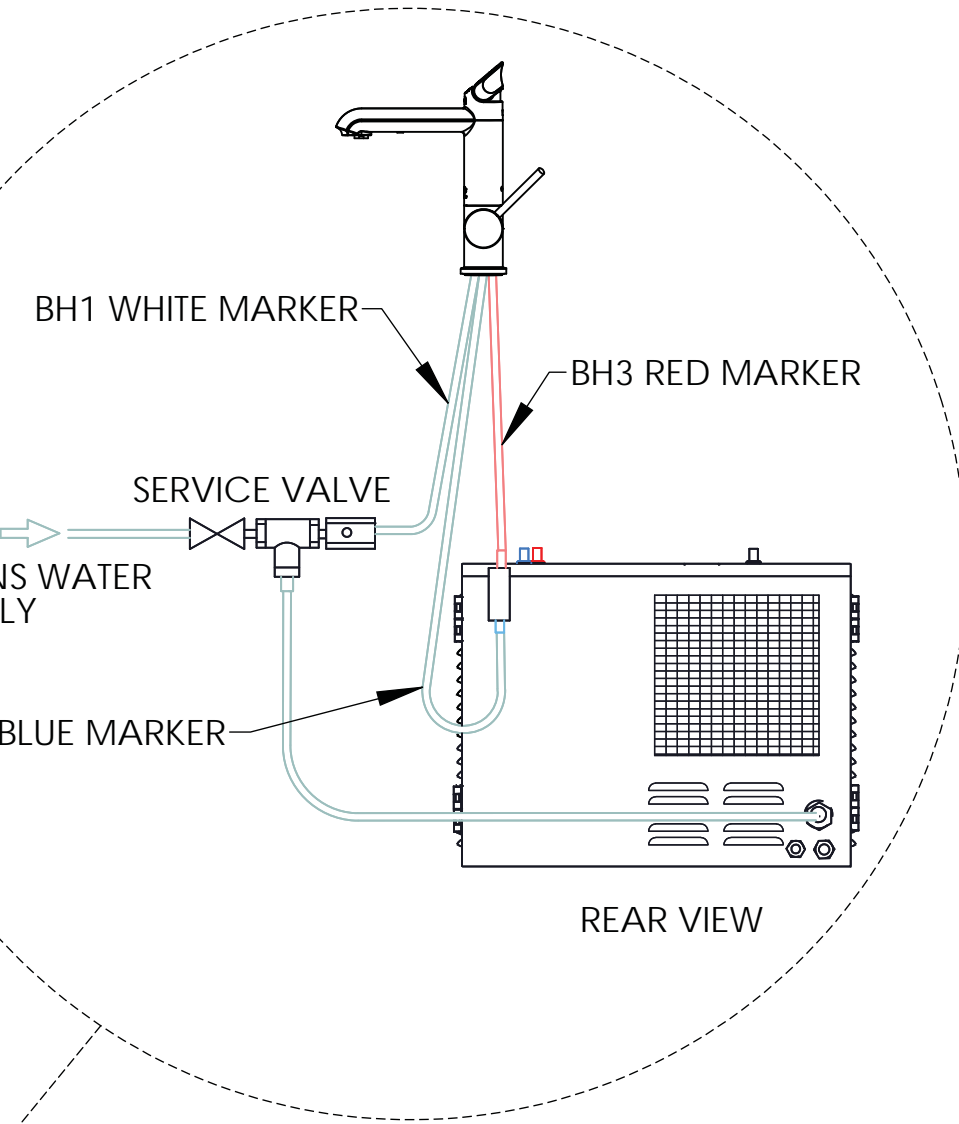

REAR VIEW

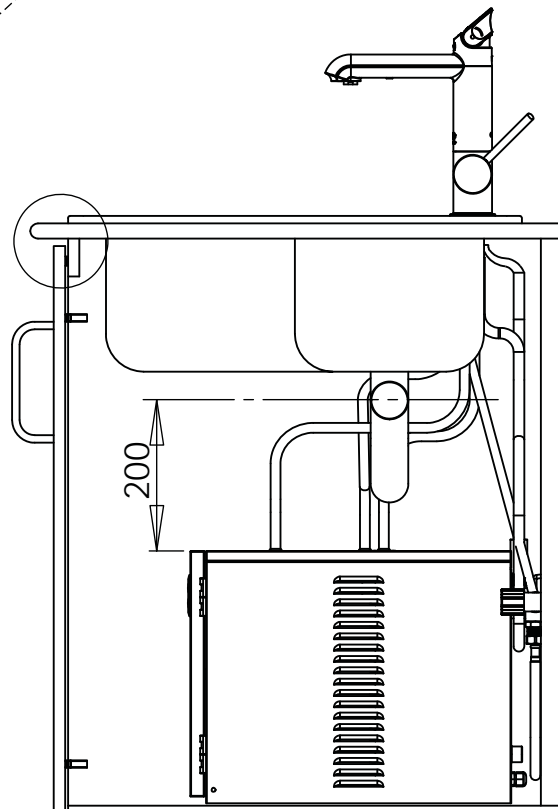
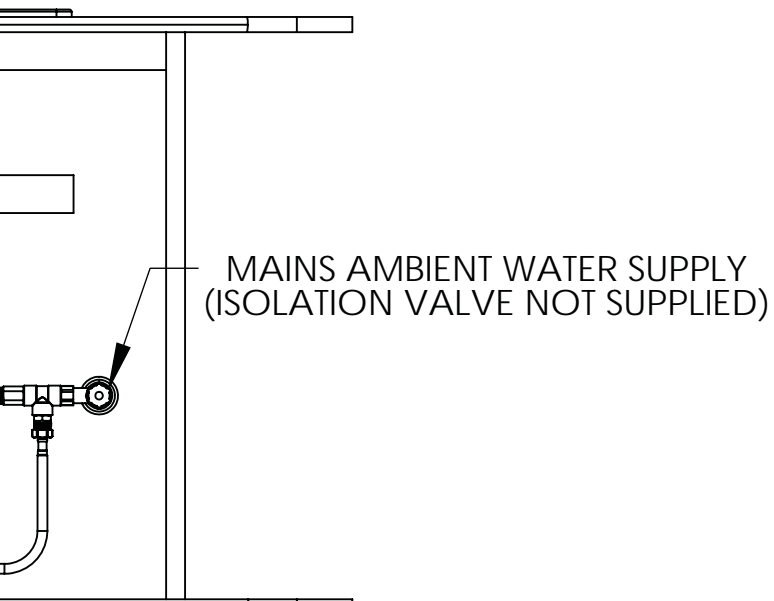

External Filter Replacement

These instructions must be read in conjunction with the filter fitting instructions supplied with the high performance filter kit.

Depending on local water quality conditions and usage, the filter may require changing anywhere from 1000 Litres to 3000 Litres. You may also need to replace the filter if you notice unpleasant odours or tastes.

To change the pre-set filter life, scroll through the menu to “External Filter Life”, press Adjust \wedge to reset litre counter. Press Adjust \wedge and it asks “are you sure”. Press Adjust \wedge again to lock in the command.

To Change the external filter:

1. Scroll through the screen menu to “Filter Flush Off” this isolates the water supply.
2. Relieve system pressure by lifting the Hot lever and allowing the water to run until it shuts off automatically (15 secs.)
3. Remove and replace the spent external filter cartridge as described in the filter kit instructions. Mop up any spills from the filter head.
4. Scroll through the menu to “External Filter Used ”, press Adjust \wedge to reset the litres. Press Adjust \wedge and it asks “are you sure”. Press Adjust \wedge again to lock in the command. After approx 10 seconds it will default to the selected mode.

Internal Filter Replacement

The Zip HydroTap notifies when filter replacement is due. The default setting is 6000 Ltrs, but this can be set in increments of 1000Ltr from 1000Ltr to 10000Ltrs. When a filter change is due, the Change Filter light will flash white once a second and remain so until reset. A filter status light is located between the Red and Blue Lights on the tap head assembly.

Depending on local water quality conditions and usage, the filter may require changing anywhere from 1000 Ltrs to 10000 Ltrs. You may also need to replace the filter if you notice unpleasant odours or tastes.

Some water may drip from the filter head (socket) during replacement. Keep a bucket and towel handy to catch drips and mop up any spills.

To change the Filter:

1. Scroll through the screen menu to “Filter Flush Off” this isolates the water supply.
2. Open the left door or on the compact model, remove the front cover by unscrewing the two Phillips headed screws and lift off to expose the filter. Unravel the Blue filter flush line and place the open end in the bucket.
3. Relieve system pressure via the filter flush stop cock, a quick open and close will do.
4. Grasp filter cartridge and twist right to left one quarter turn until it stops.
5. Ease cartridge downwards to detach it from the filter head (socket).
6. Do not tilt the cartridge as dirty water may spill from it if tilted.
7. Unpack replacement cartridge and write today’s date where shown on the label.
8. Avoid touching the filter “O” rings and filter opening as this may cause bacterial contamination of the cartridge.



HydroTap filter location

Internal Filter Replacement

9. Align cartridge tabs with the slots on the under-side of the filter head.
10. Slide cartridge upward into head and rotate left to right until it stops.
11. Locate the filter flush hose situated behind the filter cartridge and run to a container ready for flushing. Open the flush hose tap lever. On the control panel press Adjust \wedge , this will start the water flushing the cartridge. Allow at least 7.5 Ltrs of water to run through to activate the filter and then press Adjust \wedge to stop the flow.
12. Isolate the filter flush stop cock and re-fit behind the filter cartridge.
13. Wipe up any spills and dispose of spent filter cartridge and packaging thoughtfully.
14. Scroll through the menu to "Litres Filtered", press Adjust \wedge to reset litre counter. Press Adjust \wedge and it asks "are you sure". Press Adjust \wedge again to lock in the command.
15. Scroll through the menu to "Filter Used (Days)", press Adjust \wedge to reset the timer. Press Adjust \wedge and it asks "are you sure". Press Adjust \wedge again to lock in the command. After approx 10 seconds it will default to the selected mode.
16. Close the door to secure the appliance.

Warning: If the Zip HydroTap is switched off for a long period of time (e.g. more than a weekend), run water through the chilled water outlet for at least 5 minutes before consumption.

Operating the HydroTap

Press or pull lever



Blue Chilled Water Light

On all the time:

This indicates that the temperature of the chilled water is within the usable temperature range.

Flashing slowly :

This indicates that the chilled water is not at the right temperature. Wait up to 20 minutes. When the chilled water is at the right temperature, the light will stop flashing. Note: The HydroTap is designed to dispense chilled water in the temperature range 5°C to 10°C.

During heavy usage, the temperature can rise out of this range.

Red Boiling Water Light

On all the time: This indicates that the boiling water is ready.

Flashing slowly : This indicates that the boiling water is below usable temperature.

Filter Change Light Off: This indicates the filter is operating within its normal specified life span.

Filter Change Light Flashing slowly : The light will flash slowly when the filter is due for replacement and the LCD will show "Filter Change". Refer to "Replacing the filter" section of this document.

Operating the HydroTap (continued)

Boiling Filter Change Chilled

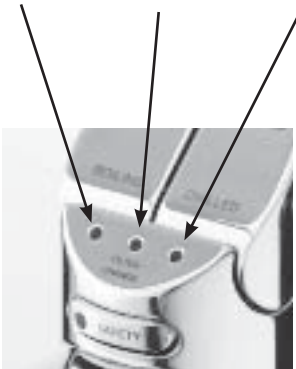

Note: On the Boiling only models the Chilled LED is blank.



Safety Lock

Boiling Water Lever

Depressing the “Red” lever allows dispensing of Boiling water.

Pulling up the Red lever allows the tap to operate in a “no-touch” mode. Water will flow from between 5 and 15 seconds (This is user adjustable). To reset, return the handle to the “Off” position and repeat the step. The lever has to be manually returned to the “Off” position.

Chilled Water Lever

Depressing the “Blue” lever allows dispensing of Chilled water.

Pulling up the Blue lever allows the tap to operate in a “no-touch” mode. Water will flow from between 5 and 15 seconds (This is user adjustable). To reset, return the handle to the “Off” position and repeat the step. The lever has to be manually returned to the “Off” position.

Safety Lock

The safety lock is designed to prevent the flow of boiling water, if the hot lever is inadvertently activated.

To operate when lock is ON, depress both the Red lever and the safety lock simultaneously.

Warning: If the HydroTap is switched off for a long period of time (e.g. more than a weekend), run water through the chilled water outlet for at least 5 minutes before consumption.

Child Safety Lock



Child safety Lock

Child Safety Lock

The child safety lock can be activated to prevent boiling water flowing if the hot lever is inadvertently activated.

To activate, first press the safety lock then depress the Blue Chilled water lever for a period of approximately ten seconds. The safety lock indicator light will now be illuminated.

To de-activate, first press the safety lock then depress the Blue Chilled water lever for a period of approximately ten seconds. The safety lock indicator light will now extinguish.

To operate when the lock is ON, depress both the Red lever and the safety lock simultaneously.

Setting the Energy Saver Timer

Menu Plus Button

Menu Minus Button



Plus Adjust Button

Minus Adjust Button

Note:

Menu buttons change the screen options

Adjust buttons select the screen options

NOTE:

Operating the Mixer tap will not De-Activate the sleep mode or the energy saver On/Off timer mode.

When the unit is in Sleep Mode, the vented model of an All-in-One tap will dispense mixed water at a temperature less than 50°C until the Hydrotap unit come out of Sleep Mode and brings the water in the hot tank to set point temperature.

Normal Operation

Set Time

To change time, press either Menu \wedge or Menu \vee button until Set Time is on the display screen. Press \wedge Adjust button to increase time or \vee Adjust button to decrease time. Time increases or decrease in increments of one minute. Hold the Adjust buttons down for rapid increases or decreases. The time will be displayed in 24Hr mode.

Set Day

Press either Menu \wedge or Menu \vee button until Set Day is displayed.

Press \wedge Adjust or \vee Adjust to select day.

Activating Sleep Mode

This mode allows the HydroTap to go into Energy Saving mode. In this mode the unit will go to "sleep" after a predetermined period of inactivity. Press either Menu \wedge or Menu \vee button until "Sleep Mode" is displayed.

Press \wedge Adjust once to select

Option 1: Sleep to 65°C after 2 hours of NO USE

Press \wedge Adjust once to select

Option 2: Auto OFF after 2 Hrs of NO USE.

When the period of inactivity passes, the display will show "Sleep Mode". During the "Sleep Mode" the Red LED on top of the tap lever will flash slowly.

Sleep to OFF means the Boiling and Chilled circuits will be switched OFF.

To de-activate the sleep mode, momentarily operate the Hot lever and then allow sufficient time for the water to reach the set temperature.

Filter Life (Factory set at 6000 Litres)

Press either Menu \wedge or Menu \vee button until Filter Life is displayed.

Press \wedge Adjust button to increase Filter Life or \vee Adjust button to decrease Filter Life.

Filter Life increases in 1000 Litre increments to a maximum of 10000 Litres.

Reset Litres Filtered

This function is to reset the Filter Change display after a filter has reached the end of its life (refer to "Replace Filter Instructions" section of this document).

Press either Menu \wedge or Menu \vee button until "Litres Filtered" is displayed. Press \wedge Adjust once and "Reset Counter" will be displayed, press \wedge Adjust button once and "Are You Sure" will be displayed.

Press \wedge Adjust once and "Litres Filtered" will be reset to 0.

Activating 'Sleep-when-it's-dark' feature

This feature will automatically switch the unit into Sleep mode Option 1 when the ambient light falls below a set level. For this system to operate correctly the sensor in the tap head must be calibrated for its surroundings.

Activation: This can only be achieved through the service mode.

To access the service mode

Press both the Adjust \blacktriangle and Adjust \blacktriangledown buttons simultaneously and hold for several seconds, until the screen displays the HOT and COLD temperatures.

Press the Menu \blacktriangledown button once to display the Auto Sleep screen.

Press the Adjust \blacktriangle button or Adjust \blacktriangledown button to select Enable or Disable.

Only after Enable has been selected can the tap head sensor be calibrated.

To Calibrate the sensor

Pull both the HOT and COLD levers forward while simultaneously pressing the safety button. All the lights will flash, hold for approximately 1 second (3 flashes) and then release.

The sensor is now calibrated for its surroundings. If there is any confusion with the surrounding light, the system will revert to Normal operation mode.

To exit from the Service mode Press both the Adjust \blacktriangle and Adjust \blacktriangledown buttons simultaneously and the screen will display Normal Operation. If the buttons are not pressed together at the same time, the Disabled option may be selected. It is important to watch the screen to ensure the system remains Enabled during the exit procedure. Check for correct operation by turning off the surrounding lights.

NOTE: When the system has entered sleep mode, due to low light conditions, the screen will display 'In Sleep Mode'. Operation of the Hot lever or an increase in the ambient light, will temporarily take the system out of sleep.

Activating 7 Day Timer On / Off Mode

Press the Menu \blacktriangle or Menu \blacktriangledown button until "Monday On" is displayed. To set the time for the unit to turn on press \blacktriangle Adjust button until required time is reached.

To set the time for the unit to turn Off press Menu \blacktriangle button once and "Monday Off" will be displayed. Now press \blacktriangle Adjust until required time is reached.

If each individual day is to have an "On / Off" time, these steps need to be repeated for each day and for each On / Off time.

Note:

The Hydrotap may be temporarily activated by operating the HydroTap levers, the unit will go into normal operation and then remain in an "ON" cycle, until the next "OFF" cycle.

Auxiliary Fan Attachment

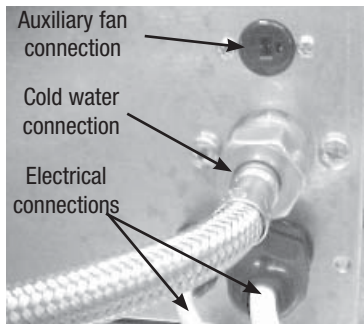

The HydroTap is equipped with an auxiliary fan connection point on the rear panel close to the cold water inlet / flex and plug area. The fan kit is available as a spare part. The fan operates in parallel with the Condenser fan helping to remove heat from the cupboard space. This fan should be purchased and connected to the HydroTap if the airflow characteristics of the cupboard space are inadequate for the effective removal of hot air, thereby adversely affecting the operation of the HydroTap.

The fan can be installed so that it extracts air from, or forces air into the cupboard space, whichever is the most effective for your installation.

Application of the fan is of paramount importance in situations where the cupboard space reaches temperatures greater than 35°C.

The exhaust fan kit must be fitted, when supplied with the appliance.

Note: The 150/175 and 200/175+ models are supplied with the auxiliary fan kit.

Boiling Water Isolation

The HydroTap is equipped with a safety mode that allows protection against accidental operation by Infirm or disabled persons.

1. On the LCD scroll through the menu to Hot Isolation.
2. Press adjust \wedge to activate.
3. Now go to the Tap Head assembly and press the Safety Lock (3) three times rapidly, the LED's will scroll from left to right (3) three times. This operation confirms the activation.
4. This isolates the boiling tap only. The LCD shows isolation mode is active.
5. To de-activate, press the Safety Lock (3) three times rapidly, the LED's will scroll from right to left (3) three times. This operation confirms de-activation.
6. The LCD will show Normal Operation.
7. If de-activation mode is required, de-activate by scrolling through the menu and selecting de-activate when Hot isolation Mode is displayed on the screen.
8. After 30 seconds of no use the unit will revert to isolation mode.

Set the Boiling & Chilled Water Dispensing Times

The ability to change the maximum dispensing time for both the Boiling and Chilled water has been introduced. The default settings for the maximum dispensing times is 15 secs. The ability to change both the Boiling and Chilled dispensing times between 5 and 15 secs, in increments of 1 sec, is accessible through the Menu screen on the LCD.

Scroll through the Menu until the Dispense Hot screen is displayed, then use the adjust buttons to set the required dispensing time for the Boiling water.

Follow the same procedure to access the Dispense Cold (for Chilled water) screens.

Trouble Shooting

Symptom	Possible Cause	Solution
No LED display, no tap head lights or, no water when tap levers are operated.	No power.	Check power supply.
	Plug is not located in power socket.	Ensure power plug is correctly fitted and switch is turned ON.
	Tap loom is not connected to HydroTap unit.	Check loom connection.
	Possible internal fault.	Contact your authorised Service Provider.
	Program in OFF cycle	Check LCD for information.
No water flow from HydroTap	Water supply isolated.	Check water supply is ON.
	Water supply not connected.	Check to ensure plumbing connection is made.
	Power supply not connected.	Check power plug is correctly fitted and switch is turned ON.
	Tap loom is not connected to HydroTap unit.	Check for loom connection
	Possible internal fault.	Contact your authorised Service Provider.
	Program in OFF cycle.	Check LCD for information.
	Child safety lock is ON	Deactivate Child safety lock.
No water flow from mixer tap	Faulty non return valve	Check and Replace faulty non return valves
	Faulty restrictaflow valve	Clean and reset restrictaflow valve
	Water supply not connected.	Check plumbing connection & turn water ON
No hot water from mixer	Hot tank empty - Excessive use	Wait for tank to refill and reheat
	Faulty venturi check valve	Replace faulty venturi check valve
Slow water recovery after use	Filter may require replacement.	Check filter usage on LCD screen, if "filter change" is displayed follow instructions on page 16 & 17.
Water not hot	Unit is in Sleep Mode.	Momentarily operate the HydroTap Hot lever and wait for the Red LED to stop flashing.
	Unit has just come out of OFF cycle.	Wait for Red LED to stop flashing.
	Possible internal fault.	Contact your authorised Service Provider.
Water not chilled	Excessive use, unit refilling or chilling down to temperature.	Wait for Blue LED to stop flashing.
	Possible internal fault.	Contact your authorised Service Provider.
Alternating display messages	More than one fault identified at the same time	Record the number and type of faults Contact your authorised Service Provider.
Hot tank overflowing	Faulty venturi check valve	Check & Replace faulty non return valves
Mixer tap operation reversed	Braided hoses incorrectly fitted	Check position of Blue and White connections

Cleaning

Do not use strong, corrosive, spray or abrasive cleaners. Clean with a soft cloth or brush and mild soap and water.

Do not spray water over the tap as it may damage the low-voltage electronics.

Undersink units must never be located near, or cleaned with water jets.

End of Life Disposal



The use of this crossed out wheeled bin logo indicates that this product needs to be disposed of separately to any other household waste.

Within each of the European Union member countries, provisions have been made for the collection and recycling of unwanted electrical and electronic equipment. Outside of the EU it will be necessary to dispose of this product at your local community waste collection or recycling centre.

In order to help preserve our environment we ask that you dispose of this product correctly. Please contact your local city council for collection centre details

Warranty

Certain warranties may be implied by law into your contract with Zip. The warranty provided below is additional to these implied warranties and nothing set out below shall limit your statutory rights or rights at law.

Zip Heaters (UK) Ltd warrants that, should any part fail within 12 calendar months of installation, that part will be repaired or replaced free of charge by Zip or its Distributor or Service Provider, except as set out below, provided the appliance is installed and used strictly in accordance with the instructions supplied, and that failure is not due to accident, misuse, abuse, unsuitable water conditions, or to any alteration, modification or repair by any party not expressly nominated by Zip.

No costs are payable by the customer other than any mileage or travelling-time charges incurred by a Zip Service Provider or the cost of removal, cartage and re-installation of any component of the appliance if it needs to be returned for repair to Zip or its Distributor.

This warranty does not cover damage resulting from non-operation of the appliance, the use of non authorised parts or consequential damage to any other goods, furnishings or property.

No warranty applies to the life of any filtration cartridge installed with the appliance as cartridge life may vary according to water quality and the rate of water consumption.

Zip does not exclude, restrict or modify any liability that cannot be excluded, restricted or modified or which cannot, except to a limited extent, be excluded, restricted or modified as between the owner or user and Zip under the laws applicable.

Furthermore, this warranty does not displace any statutory warranty, but, to the extent to which Zip is entitled to do so, the liability of Zip under any statutory warranty will be limited at Zip's option to the replacement of the appliance or supply of equivalent appliance, the payment of the cost of replacing the appliance or acquiring an equivalent appliance, or the payment of the cost of having the appliance repaired or the repair of the appliance.

Registering Your Purchase

Registering your Zip installation on the Zip website may help to establish date of installation should it become necessary to service the appliance under terms of the Zip warranty. To register your installation go to www.zipheaters.co.uk and look under the heading "Warranty".

As Zip policy is one of continuous product improvement, changes to specifications may be made without prior notice. Images in this booklet have been modified and may not be true representations of the finished goods.

Head Office

Zip Heaters (UK) Ltd
14 Bertie Ward Way
Dereham
Norfolk NR19 1TE

Website: www.zipheaters.co.uk
sales@zipheaters.co.uk

Telephone: 0845 602 4533
Facsimile: 01362 692 448.



The standard cup referred to in this publication is 167 ml (6 fl oz).

The standard glass is 200 ml (7 fl oz).

The terms "Zip" and "HydroTap" are registered trade marks of Zip Heaters (Aust) Pty Ltd.

Zip products described in this publication are manufactured under one or more of the following patents: AU675601, AU637412, AU635979, GB0422305, GB2065848, US4354049, US5103859, and US5099825. Other patents are in force and patent applications are pending.

