

Section 3
Features

Absent Message Capability

Allows an extension user to set a message which will be displayed at the calling extension to show the reason for the called extension's absence. One of 6 messages can be programmed as desired, which are available for any telephone (single line telephone or proprietary telephone). Setting or cancelling a message can be done by individual extension users but only callers using a proprietary telephone with a LCD can see the message.



- The 6 messages are shown below. “%” means a parameter to be entered when assigning a message at an extension.
 - (1) Will Return Soon
 - (2) Gone Home
 - (3) At Ext %%% (extension number)
 - (4) Back at %% : %% AM (or PM) (hour : minute)
 - (5) Out Until %%/%% (day / month)
 - (6) In a Meeting
- An extension user can only select one message at a time. The selected message is displayed every time the user goes off-hook.



- **Operating Instructions Reference**
 - 1.6 Before Leaving Your Desk, “Showing Your Message on the Calling Party’s Display (Absent Message Capability)”

Account Code Entry

An account code is used to identify incoming and outgoing outside calls for accounting and billing purposes. The account code is appended to the SMDR call record. For incoming outside calls, an account code is optional. For outgoing outside calls, there are 4 account input modes programmable in program [605], Option, Forced, Verify–All and Verify–Toll.

- Option:** A 4-digit code may be entered during a conversation or within 30 seconds after a conversation when a record is needed.
- Forced:** A 4-digit code must be entered within 5 seconds after an exchange line is seized. The code can be any number.
- Verify–All:** Enables to make an outside call if the code entered within 5 seconds after an extension user seizes an exchange line is the same as one of the account codes programmed in [310].
- Verify–Toll:** Enables to override call barring temporarily by entering one of the account codes programmed in [310] within 5 seconds after an exchange line is seized. Calls with COS numbers 3 through 5 will be treated as calls with COS number 2. Calls with COS numbers 1 and 2 will not be affected.



- **Required System Programming**

- [\[310\] Account Codes](#)
- [\[601\]-\[603\] Call Barring – Class of Service Assignment —Day/Night/Lunch](#)
- [\[605\] Account Code Entry Mode](#)
- [\[805\] SMDR Account Code Selection](#)

- **Related Feature References**

- Station Message Detail Recording (SMDR),
- Call Barring Override by Account Codes

- **Operating Instructions Reference**

- 1.7 Useful Features, “Calling with Account Codes (Account Code Entry)”

Alternate Calling – Ring/Voice

This system offers a proprietary telephone user 2 types of intercom calling, Voice Call mode and Tone (ring) Call mode. “Voice Call” informs the called party of an incoming call with the calling party’s voice, while “Tone Call” uses a ring tone. A proprietary telephone user can select “Voice Call” or “Tone Call” in the Proprietary Telephone Settings. If the user selects “Voice Call”, the calling party can talk to the user immediately after the confirmation tone. The calling party can switch the pre-set mode at the called extension, from “Voice Call” to “Tone Call” or vice versa, by pressing “*” after dialling the extension number.



- A rotary telephone user cannot change the pre-set mode at the called extension.



- **Operating Instructions References**

- 1.2 Proprietary Telephone Settings, “Customising Your Telephone Functions”, Intercom Alert Assignment
- 1.7 Useful Features, “Alternate Calling – Ring/Voice”

Automatic Callback Busy (Camp-On)

When the selected exchange line or dialed extension is busy, the system will automatically notify an extension user with a callback ringing when the line becomes available. When the user answers the callback ringing:

For an extension: The called extension starts ringing without dialling.

For an exchange line: The line is seized.



- **Operating Instructions Reference**

- 1.3 Making Calls, “Making Your Telephone Ring Back Automatically When a Line Becomes Free (Automatic Callback Busy – Camp-On)”

Automatic Exchange Line Access Number

An Automatic Line Access number (0 or 9) can be programmed. When an extension user dials an Automatic Line Access number before a telephone number, an available exchange line from the assigned lines in program [419] is seized automatically. If “0” is selected in program [121], the operator call will be “9” automatically. If “9” is selected in program [121], the operator call will be “0” automatically.



- **Related Feature References**

- Operator Call, Outside Calling

- **Required System Programming**

- [\[121\] Automatic Exchange Line Access Number Selection](#)

- [\[419\] Automatic Designated Exchange Line Access](#)

Automatic Route Selection (ARS)

The system automatically selects the least expensive route available at the time a long distance call is made on the exchange line enabled for ARS feature. It is not necessary to dial the access code of the least expensive carrier.

1. Normal Use

To make a call via the least expensive carrier, the dialled number is modified. The following are modification examples.

Example 1 (Long distance call using Route 1):

[350] "ARS Selection": Enable
 [351] "Route 1 Selection Codes (Leading Digit)": 0
 [355] "Route 1 Exception Codes": 07
 [360] "ARS Modification – Removed Digits": 0 (No deletion)
 [361] "ARS Modification – Added Number": 131(Code of least expensive carrier for a long distance call)
 [381] "Route 1 Authorisation Code": 0123456789
 [385] "Route 1 Itemised Bill": Enable
 [389] "Itemised Bill Code Assignment": 201

| <Dialled number> | → | <Modified number> |
|------------------|---|----------------------------------|
| 01633 877 467 | → | 131 0123456789 201 01633 877 467 |

Example 2 (International call using Route 2):

[350] "ARS Selection": Enable
 [352] "Route 2 Selection Codes (Leading Digit)": 00
 [360] "ARS Modification – Removed Digits": 0
 [361] "ARS Modification – Added Number": 1620 (Code of least expensive carrier for an international call)
 [386] "Route 2 Itemised Bill": Enable
 [389] "Itemised Bill Code Assignment": 201

| <Dialled number> | → | <Modified number> |
|-------------------|---|----------------------------|
| 00 44 1344 853941 | → | 1620 201 00 44 1344 853941 |

Example 3 (Long distance call via the first carrier):

[350] "ARS Selection": Enable
 [359] "1st Carrier Selection Code": 121

| <Dialled number> | → | <Modified number> |
|-------------------|---|-------------------|
| 121 01633 877 467 | → | 01633 877 467 |

2. Special Use

If an extension user always uses the Automatic Line Access number (9 or 0) when making an outside call and wants to seize the specified trunk group as below automatically, refer to the following program assignment.

<Example>

- Trunk group which connects with the least expensive carrier for a long distance call (Long distance calls start with “0”. Carrier code = 131)
- Trunk group which connects with the least expensive carrier for an international call (International calls start with “00”. Carrier code = 1620)
- Trunk group connected to a mobile telephone (No modification of the dialed number is necessary.)

To specify how to modify the dialed number, and specify a trunk group for each route

| Program Address Route No. | [351] [354] | [355] [358] | [360] | [361] | [364] |
|------------------------------|---------------------|---------------------|----------|-------|----------------------|
| Route 1 | 0 | 07 | 0 digit | 131 | trunk group number 1 |
| Route 2 | 00 | | 0 digits | 1620 | trunk group number 1 |
| Route 3 | 079 | | 0 digit | | trunk group number 2 |

To specify exchange lines in the trunk groups

| Program Address Exchange Line No. | [404] Trunk Group Assignment | [350] | [419] Automatic Designated Exchange Line Access |
|--------------------------------------|------------------------------|--------|-------------------------------------------------|
| 1 | trunk group number 1 | Enable | Enable |
| 2 | trunk group number 1 | Enable | Enable |
| 3 | trunk group number 2 | Enable | Disable |

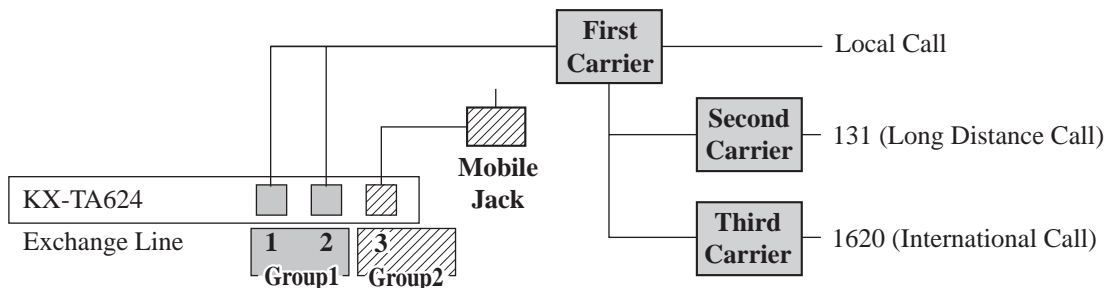

Example 5 [Long distance call using Route 1 (trunk group number 1)]:

| | | |
|------------------|--------|-------------------|
| <Dialled number> | | <Modified number> |
| 9 01633 877 467 | —————> | 131 01633 877 467 |

Example 6 [International call using Route 2 (trunk group number 1)]:

| | | |
|---------------------|--------|----------------------------|
| <Dialled number> | | <Modified number> |
| 9 00 44 1344 853941 | —————> | 1620 201 00 44 1344 853941 |

Example 7 [Mobile telephone call using Route 3 (trunk group number 2)]:

| | | |
|------------------|--------|-------------------|
| <Dialled number> | | <Modified number> |
| 9 07979 123456 | —————> | 07979 123456 |

- System Programming is required to execute this feature.
- If an extension user makes an outside call using the Automatic Line Access number (9 or 0) and the dialled number does not apply to any numbers assigned in programs [351]–[354], an exchange line which has selected “Enable” in program [419] “Automatic Designated Exchange Line Access” is automatically seized.



- **Required System Programming**

- [350] ARS Selection
- [351]-[354] Routes 1 through 4 Selection Codes (Leading Digits)
- [355]-[358] Routes 1 through 4 Exception Codes
- [359] 1st Carrier Selection Code (BT Line Access Code)
- [360] ARS Modification – Removed Digits
- [361] ARS Modification – Added Number
- [362] ARS Dial Tone Pattern Selection
- [363] ARS Interdigit Time
- [364] ARS Trunk Group
- [381]-[384] Routes 1 through 4 Authorisation Codes
- [385]-[388] Routes 1 through 4 Itemised Bill
- [389] Itemised Bill Code Assignment

Flow chart of possible cases and results for ARS calls

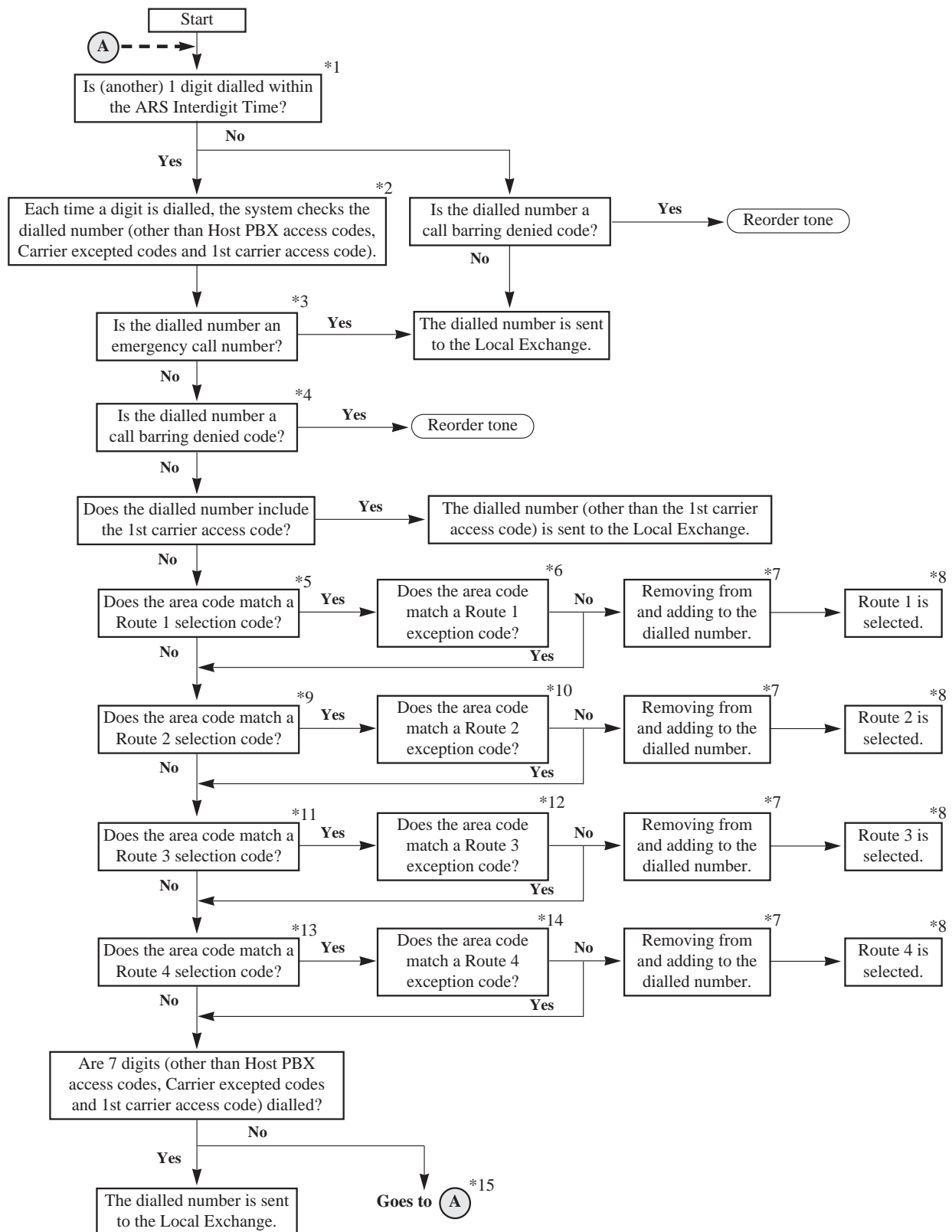

- *1: The ARS Interdigit timer is assigned in program [363] “ARS Interdigit Time”.
- *2: The codes are assigned in the following programs.
 - Host PBX access codes: [403] “Host PBX Access Codes”
 - Carrier excepted codes: [300] “Carrier Excepted Code Assignment”
 - 1st carrier access code: [359] “1st Carrier Selection Code”.
- *3: Emergency call numbers are assigned in program [309] “Emergency Dial Number Set”.
- *4: Call Barring denied codes are assigned in program [302]-[305] “Call Barring – Classes 2 through 5 Denied Codes”.
- *5: Route 1 selection codes are assigned in program [351] “Route 1 Selection Codes (Leading Digits)”.
- *6: Route 1 exception codes are assigned in program [355] “Route 1 Exception Codes”.
- *7: Removing digits are assigned in program [360] “ARS Modification – Removed Digits” and added numbers are in [361] “ARS Modification – Added Number”
- *8: The trunk group(s) assigned in program [364] is (are) automatically seized when making a call using the Automatic Exchange Line Access number (0 or 9).
- *9: Route 2 selection codes are assigned in program [352] “Route 2 Selection Codes (Leading Digits)”.
- *10: Route 2 exception codes are assigned in program [356] “Route 2 Exception Codes”.
- *11: Route 3 selection codes are assigned in program [353] “Route 3 Selection Codes (Leading Digits)”.
- *12: Route 3 exception codes are assigned in program [357] “Route 3 Exception Codes”.
- *13: Route 4 selection codes are assigned in program [354] “Route 4 Selection Codes (Leading Digits)”.
- *14: Route 4 exception codes are assigned in program [358] “Route 4 Exception Codes”.
- *15: The system repeats checking until 7 digits are dialed.

Busy Extension Signalling

When an extension user calls a busy extension, the busy extension will hear a Call Waiting tone to know that a call is waiting.



- This feature is only available if the called extension has set the Call Waiting feature. If the Call Waiting feature is activated, the caller will hear a ringback tone. If not, the caller will hear a reorder tone.



- **Related Feature Reference**

Call Waiting

- **Operating Instructions Reference**

1.3 Making Calls, “Sending a Call Waiting Tone to a Busy Extension (Busy Extension Signalling)”

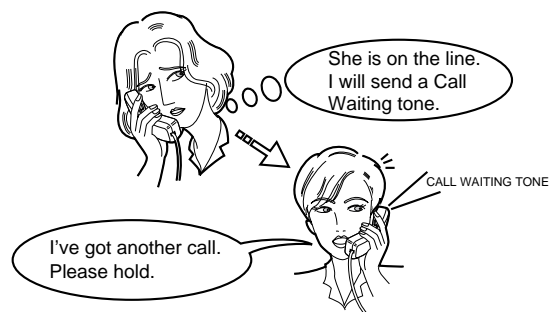

Call Barring

Call Barring is a system programmable feature that can prohibit certain extension users from making unauthorised toll calls.

Every extension is programmed to belong to one of 5 classes of service (COS). Each COS is programmed to have a call barring class for day mode, night mode and lunch mode.

There are 5 call barring COS numbers available. Call barring COS number 1 is the highest class and the COS number 5 is the lowest. That is, COS number 1 allows all toll calls. COS numbers 2 through 5 are used to restrict calls by combining pre-programmed deny and exception codes shown in the table on the next page.

Denied Codes

An outgoing outside call made by an extension with a call barring COS number between 2 and 5 is first checked against the assigned denied codes in program [302]-[305].

If the first digits of the dialled number (not including the line access code) are not found in the class, the call can be made. Each class can store up to 20 denied codes, each consisting of 11 digits.

Exception Codes

These codes are used to override a programmed denied code. A call denied by the denied codes is checked against the selected exception codes assigned in program [306]. If a match is found, the call can be made.

Up to 80 exception codes, each consisting of 11 digits, can be stored. The available number of codes depends on the COS number.



- Emergency numbers, such as the police or fire station, should be stored in program [309] “Emergency Dial Number Set” so that they are exempt from call barring.
- If a stored Host PBX access code in program [403] “Host PBX Access Codes” or a stored carrier code in program [300] “Carrier Excepted Code Assignment” is found in the dialled number, the subsequent telephone numbers will be checked for call barring.
- The interdigit timer assigned in program [208] “Interdigit Time” applies until the call barring check is completed. When the timer expires, an outside outgoing call will be disconnected while dialling, if “Enable” was selected in program [211] “No Dial Disconnection”.
- The call barring class for a locked extension can be assigned in program [312] “Call Barring – Extension Lock Boundary Class” so that even a locked extension can make a local call, etc.
- It is programmable whether the “*” or “#” the user dials is to be checked or not on the Call Barring code in program [125] “Call Barring Check for * and #”. This is useful to prevent unauthorised calls which could be possible through certain Local Exchange systems.



Required System Programming

- [\[301\] Call Barring – System Speed Dialling Boundary Class](#)
- [\[302\]-\[305\] Call Barring – Classes 2 through 5 Denied Codes](#)
- [\[306\] Call Barring – Exception Codes](#)
- [\[601\]-\[603\] Call Barring – Class of Service Assignment – Day/Night/Lunch](#)

Related Feature References

- Emergency Call
- Call Barring – Extension Lock Boundary Class
- Call Barring for System Speed Dialling
- Call Barring Override by Account Codes

Combination of denied codes and exception codes

| COS No. | Denied Calls | Excepted Calls |
|---------|-----------------------------------------------------------------------------------------------------------------------------------------------------------------|--------------------------------------------------------------|
| 1 | No restriction. | No restriction. |
| 2 | 20 denied codes programmed in [302]. | 80 exception codes (code numbers 01-80) programmed in [306]. |
| 3 | 20 denied codes programmed in [302] plus 20 denied codes programmed in [303]. | 60 exception codes (code numbers 01-60) programmed in [306]. |
| 4 | 20 denied codes programmed in [302] plus 20 denied codes programmed in [303] plus 20 denied codes programmed in [304]. | 40 exception codes (code numbers 01-40) programmed in [306]. |
| 5 | 20 denied codes programmed in [302] plus 20 denied codes programmed in [303] plus 20 denied codes programmed in [304] plus 20 denied codes programmed in [305]. | 20 exception codes (code numbers 01-20) programmed in [306]. |

Flow chart of Call Barring

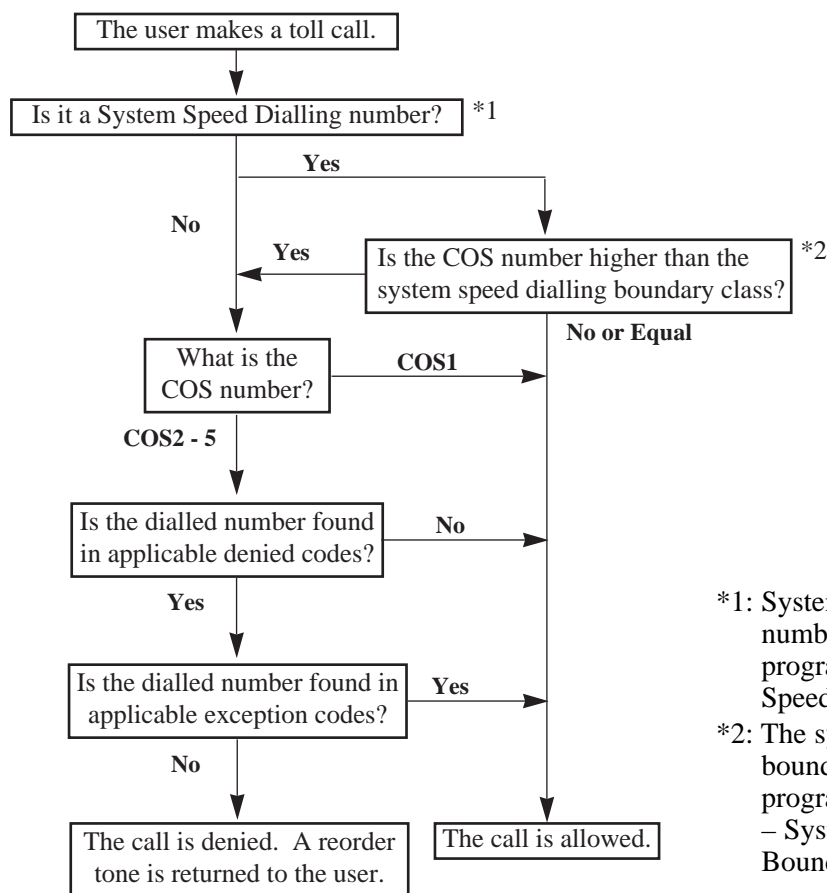

*1: System Speed Dialling numbers are assigned in program [001] "System Speed Dialling Entry".

*2: The system speed dialling boundary class is assigned in program [301] "Call Barring – System Speed Dialling Boundary Class".

Call Barring — Extension Lock Boundary Class

Allows assigning a call barring class for extensions where the Electronic Extension Lockout or Remote Extension Lock feature has been set.

An extension user usually cannot make an outside call at a locked extension, however if a call barring class is assigned in program [312], the user can make an outside call at the locked extension.



- The higher call barring class number will take precedence.
For example, if call barring COS number 3 is assigned to an extension and the extension lock boundary class is 4, the extension user is allowed to make a call with call barring COS number 4.



- **Required System Program Address**
[\[312\] Call Barring – Extension Lock Boundary Class](#)
- **Related Feature References**
Extension Lock, Call Barring

Call Barring for System Speed Dialling

Calls originated by System Speed Dialling are restricted depending on the combination of the System Speed Dialling Boundary Class assigned in program [301] and the class of service (COS) assigned to each extension as follows.

| System Speed Dialling Boundary Class COS No. | 1 | 2 | 3 | 4 | 5 |
|-------------------------------------------------|---|---|---|---|---|
| 1 | A | A | A | A | A |
| 2 | C | A | A | A | A |
| 3 | C | C | A | A | A |
| 4 | C | C | C | A | A |
| 5 | C | C | C | C | A |

A: allowed C: checked

<Example>

—If the boundary is set to COS number 2, The system will allow system speed dialling for COS numbers 1 and 2, but check COS numbers 3, 4 and 5 according to call barring.



- **Required System Programming**
[\[301\] Call Barring – System Speed Dialling Boundary Class](#)
- **Related Feature Reference**
Call Barring

Call Barring Override by Account Codes

Allows an extension user to override call barring temporarily to make a toll call from a toll-restricted extension. The user can carry out this feature by entering one of the account codes programmed in [310] “Account Codes” before dialling the telephone number. The user can make a toll call with the COS number 2.



- The account code “Verify-toll (call barring)” mode at an extension permits users to override their call barrings.
- This feature can be used on extensions assigned to call barring COS numbers 3 through 5. The COS numbers 1 and 2 will not be changed.
- If the user does not enter an account code or enters an invalid one, a regular call barring check is done.
- When a user makes a call using this feature, it will appear on the SMDR printout with either the entered 4-digit account code or the 2-digit index of the entered account code. This selection is set in program [805].
- Users can also override call barring of another extension by using the Walking COS feature.

Flow chart of Call Barring Override

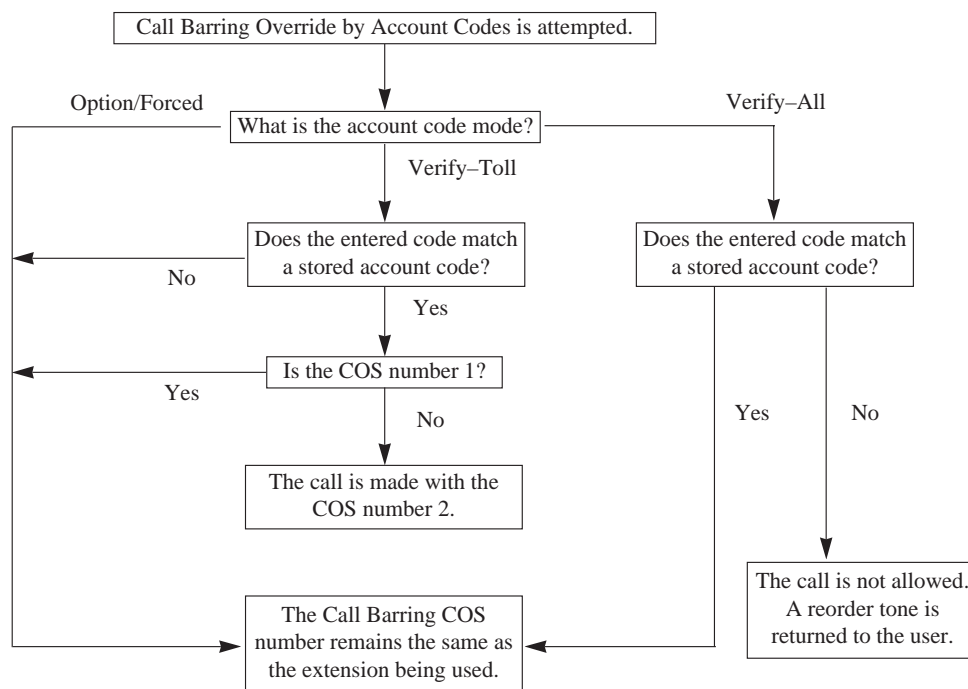

- **Required System Programming**
 - [\[310\] Account Codes](#)
 - [\[605\] Account Code Entry Mode](#)
 - [\[805\] SMDR Account Codes Selection](#)

- **Related Feature References**

Account Code Entry, Call Barring, Station Message Detail Recording (SMDR), Walking COS

Call Forwarding

Allows an extension user to transfer incoming calls automatically to another extension or to an external destination. The following types are available.

- All Calls:** All incoming calls are forwarded to another extension.
- Busy or No Answer:** All incoming calls are forwarded to another extension when the extension user does not answer within the programmed time in [202] or when the extension is busy.
- To an Exchange Line:** Allows an extension user enabled in program [607] to forward all incoming intercom calls to an external party.
- Follow Me:** Allows an extension user to set the Call Forwarding – All Calls feature from another extension.



- Extensions which have already been assigned as a forwarded destination cannot set the Call Forwarding feature.
- If the Do Not Disturb (DND) feature has already been set, setting the Call Forwarding feature will cancel DND.
- When using the call forward to an exchange line feature the quality of service may be adversely affected by the attenuation across the public telephone network.



- **Required System Programming**
 - [\[202\] Call Forwarding Start Time](#)
 - [\[607\] Call Forwarding to an Exchange Line](#)
- **Related Feature Reference**
 - Limited Call Duration
- **Operating Instructions References**
 - 1.2 Proprietary Telephone Settings, “Customising the Buttons on Your Telephone”, FWD/DND (Forward/Do Not Disturb) Button
 - 1.6 Before Leaving Your Desk, “Forwarding a Call (Call Forwarding)”

Calling Party Control (CPC) Signal Detection

The Calling Party Control (CPC) signal is a disconnect signal sent from the Local Exchange for an outside call. The CPC signal detection is activated by programs [420] and [421]. Program [420] is for incoming outside calls, and [421] is for outgoing outside calls.



- **Required System Programming**
 - [\[420\] Calling Party Control \(CPC\) Signal](#)
 - [\[421\] CPC Detection for Outgoing Calls](#)

Call Park

Allows an extension user to place a held call into a system parking area. Any extension user can retrieve the parked call to perform other operations. Up to 10 calls can be parked at the same time.



- If a parked call is not retrieved within the assigned time in program [200], a ring tone or an alarm tone will be heard.
- If a parked call is not retrieved within 30 minutes, it will be automatically disconnected.
- This feature is useful when an extension user wants to hold more than one intercom call with a proprietary telephone, or more than one intercom call or outside call with a single line telephone.
- During a 5-party conference, this feature cannot be performed.



- **Required System Programming**

- [200] Hold Recall Time

- **Related Feature Reference**

- Conference (5-party)

- **Operating Instructions Reference**

- 1.5 During Conversation, “Placing a Call in System Parking Area (Call Park)”

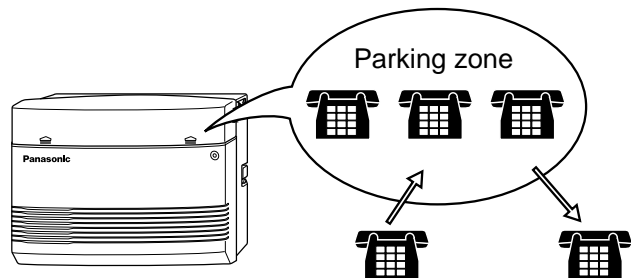

Call Pickup

<Directed Call Pickup>

Allows an extension user to answer a call ringing at any other extension.

<Group Call Pickup>

Allows an extension user to answer a call ringing at another extension, if the call is ringing within the user's extension group assigned in program [600]. If "Enable" is selected for an extension group in [127], persons in the group can pickup calls just by going off-hook, even though their extension is not ringing.

<Call Pickup Deny>

Allows an extension user to prevent other extensions from picking up a call ringing at the user's extension with the Call Pickup feature.

<Call Retrieving from a TAM (Telephone Answering Machine)>

Allows an extension user to answer an incoming call received by a TAM extension assigned in program [611].



- The user can pick up an incoming outside, intercom or doorphone call with the Directed Call Pickup or Group Call Pickup feature.
- A confirmation tone is sent to the user when the call is picked up with the Directed Call Pickup or Group Call Pickup feature. The tone can be disabled in program [117].
- If a ringing extension sets the Call Pickup Deny feature, an extension user will hear a reorder tone when the user tries to pick up the call.



• Required System Programming

- [117] Call Pickup Tone
- [127] Pickup Group Set
- [600] Extension Group Assignment
- [611] TAM (Telephone Answering Machine) Extension

• Operating Instructions Reference

- 1.4 Receiving Calls, "Picking up a Call Ringing at Another Extension (Call Pickup)"



Call Splitting

Allows an extension user to talk to 2 different parties. If a call is received while the user is already on the line, the user can place the current call on hold and have a conversation with the other party.



- This feature is not possible for a doorphone call, page or 5-party conference.



• Related Feature References

Conference (5-party), Doorphone Call, Paging

• Operating Instructions Reference

- 1.5 During Conversation, "Call Splitting"

Call Transfer – to Exchange Line

Allows an extension user enabled in program [606] to transfer a received intercom call to an external party.



- A single line telephone user cannot transfer a received call to an external party.
- To join the conversation again after transferring the call, press the corresponding line key. A conference call will be established. This feature is not available for a single line telephone.



- **Required System Programming**
[\[606\] Call Transfer to an Exchange Line](#)
- **Related Feature Reference**
 Hold, Limited Call Duration
- **Operating Instructions Reference**
 1.5 During Conversation, “Transferring a Call to an Exchange Line (Call Transfer – to Exchange Line)”

Call Transfer – to Extension

Allows an extension user to transfer a received call, an intercom or an outside call, to another extension. Two types are available.

Screened Call Transfer: Announces the call to another extension before completing the transfer.

Unscreened Call Transfer: Immediately releases the call to another extension without an announcement.



- If the destination extension does not answer the call within the assigned time in program [201], the call will return to the transferring party.
- An outside call can be transferred to an extension by simply pressing a DSS button. It requires program [005].
- If Music on Hold is enabled, music is sent to the original external caller while being transferred. Sending a cyclic tone or music on hold can be programmed by program [111].
- During a 5-party conference, the user cannot transfer a call.



- **Required System Programming**
[\[005\] One-Touch Transfer Using a DSS Button](#)
[\[111\] Hold Music Selection](#)
[\[201\] Transfer Recall Time](#)
- **Related Feature References**
 Conference (5-party), Hold, Music on Hold
- **Operating Instructions Reference**
 1.5 During Conversation, “Transferring a Call to an Extension (Call Transfer – to Extension)”

Call Waiting

During a conversation, a Call Waiting tone informs an extension user that there is a call waiting. The user can answer the second call by disconnecting the first call or placing it on hold. When Call Waiting is enabled, a Call Waiting tone is sent to the user under the following conditions.

- 1) When an outside call (except a doorphone call) is received, or
- 2) When another extension executes the Busy Extension Signalling feature.



- For proprietary telephone users, a Call Waiting tone (Tone 1 or Tone 2) can be selected in the Proprietary Telephone Settings. Tone 2 depends on System Programming. Program [423] is for outside calls and program [115] is for intercom calls.



- **Required System Programming**
 - [\[115\] Extension Ringing Pattern Selection](#)
 - [\[423\] Exchange Line Ringing Pattern Selection](#)
- **Related Feature Reference**
 - Hold
- **Operating Instructions References**
 - 1.2 Proprietary Telephone Settings, “Customising Your Telephone Functions”, Call Waiting Tone Selection
 - 1.5 During Conversation, “Call Waiting”

Conference (3-party)

During a 2-party conversation, an extension user can add a third party to make a 3-party conference. The maximum number of members of a conference can be programmed in program [116].



- The possible combinations, through System Programming, are 3 extensions, 1 extension and 2 external parties, or 2 extensions and 1 external party.
- When a 2-party call is changed to a 3-party call or vice versa, a confirmation tone is sent to all 3 parties. The tone can be disabled by program [105].
- A 3-party call can also be established by the Executive Busy Override feature.



- **Required System Programming**

- [\[105\] Conference Tone](#)

- [\[116\] Conference Pattern Selection](#)

- [\[606\] Call Transfer to an Exchange Line](#)

- **Related Feature References**

- Executive Busy Override

- **Operating Instructions References**

- 1.2 Proprietary Telephone Settings, “Customising the Buttons on Your Telephone”,
CONF (Conference) Button

- 1.7 Useful Features, “Conference (3-party)”

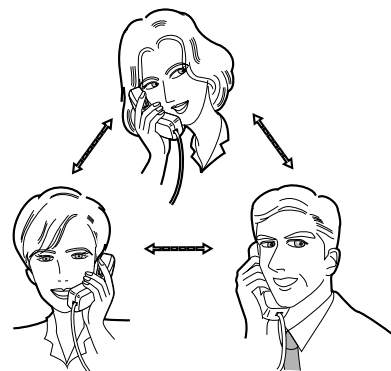

Conference (5-party)

Allows an extension user to establish a 5-party conference when “5 party C-2 E-5” is selected in program [116].



- Up to 2 external parties can participate in a conference call.
- All 5 parties can be extensions.
- Only one 5-party conference can be established at one time.
- When a 5-party conference is established, a confirmation tone is sent to all parties. The tone can be disabled by program [105].
- The Executive Busy Override and the Call Park features are not available during a 5-party conference.



- **Required System Programming**

- [\[105\] Conference Tone](#)

- [\[116\] Conference Pattern Selection](#)

- **Related Feature References**

- Conference (3-party), Call Park, Executive Busy Override

- **Operating Instructions References**

- 1.2 Proprietary Telephone Settings, “Customising the Buttons on Your Telephone”, CONF (Conference) Button

- 1.7 Useful Features, “Conference (5-party)”

Data Line Security

Prevents an extension user from being interrupted by the Call Waiting and Executive Busy Override features. This feature also prevents a ring tone or an alarm tone from being sent when a call is kept waiting longer than a pre-determined time. Data communication devices, such as computers and facsimiles, connected to an extension port can operate without interruptions.



- **Related Feature References**

- Call Waiting, Executive Busy Override

- **Operating Instructions Reference**

- 1.7 Useful Features, “Data Line Security”

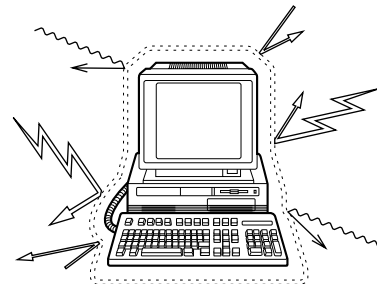

Date and Time Setting

A manager or operator can adjust the current time.



- **Required System Programming**
[000] [Date and Time Setting](#)
- **Operating Instructions Reference**
1.8 Operator / Manager Service Features, “Date and Time Setting”

Direct In Line (DIL)

Enables an incoming outside call to go directly to a specified extension. This exchange line can be used by multiple extension users to make a call, but can only be used by one extension to receive a call. DIL can have a different destination in the day, night and/or lunch modes.



- If the destination extension is in an extension group which has enabled the Extension Hunting feature in program [100] “Hunting Group Set”, Extension Hunting (Terminate or Circular in program [101] “Hunting Type”) works when the extension is busy.



- **Required System Programming**
[414]–[416] [Exchange Line Mode — Day/Night/Lunch](#)
- **Related Feature References**
Extension Hunting, Time (Day/Night/Lunch) Service

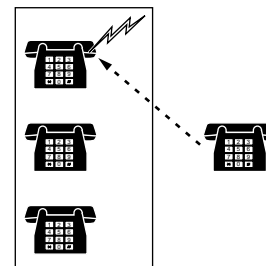

Direct Inward System Access (DISA)

Allows an outside caller to access specific system features as if the caller is an extension in the system. The caller can have direct access to features such as:

- Placing an incoming call to an extension, extension group or operator. The caller also has the option of dialling the route for an extension using a 1 digit number (DISA built-in auto attendant number) via DISA calls.

The DISA feature operates without an optional card installed. If an outgoing message (OGM) which greets a caller and gives information, or fax detection is required, an optional OGM/FAX Detection Card must be installed. The system can detect a FAX (CNG) tone according to program [514]. An OGM can be programmed in program [502] (☞ “Outgoing Message (OGM)” in this section). When a caller reaches a DISA line, a message will greet the caller. Two different DISA messages can be recorded by the operator or manager. For example, one message can be used in day mode and the other in night mode, or they can be used for different exchange lines. If an optional OGM/FAX Detection Card is not installed, the caller will hear a short beep instead of the OGM (Internal DISA).



- “DISA1” or “DISA 2” must be assigned to exchange line(s) as the exchange line mode in programs [414] through [416].
- After the DISA Delayed Answer Time assigned in program [504] expires and a ringback tone is returned to the caller, a DISA call will be answered. The caller can dial during the message or after the tone.
- This system can store up to 10 programmable DISA built-in auto attendant numbers in program [501]. Each number is 1 digit.
- The DISA built-in auto attendant number may be the same as the first digit of other numbers (extension number, etc.). To avoid confusion, the system waits for the second digit for a preprogrammed amount of time in program [517] (default: 2 seconds). If the timer expires, the system will assume that the first digit is a DISA built-in auto attendant number.
- Only one OGM/FAX Detection Card can be installed .



- **Connection Reference**

- 2.15 OGM/FAX Detection Card Installation

- **Required System Programming**

- To enable the DISA feature**

- [\[414\]–\[416\] Exchange Line Mode — Day/Night/Lunch](#)

- [\[420\] Calling Party Control \(CPC\) Signal](#)

- [\[500\] DISA Incoming Dialling Mode Selection](#)

- [\[501\] DISA Built-in Auto Attendant](#)

- [\[502\] OGM Mode Selection](#)

- [\[503\] FAX Connection](#)

- [\[506\] DISA Busy Mode](#)

- [\[510\] DISA No Dial Mode](#)

- [\[513\] Cyclic Tone Detection](#)

- [\[514\] FAX Tone Detection](#)

- [\[516\] DISA Incoming Assignment](#)

- To set DISA timer values**

- [\[504\] DISA Delayed Answer Time](#)

- [\[505\] DISA Waiting Time after OGM](#)

- [\[517\] DISA AA Wait Time](#)

- [\[519\] DISA OGM Mute Time](#)

- To enable the Intercept Routing feature**

- [\[408\]–\[410\] Flexible Ringing Assignment — Day/Night/Lunch](#)

- [\[507\] DISA Intercept Mode](#)

- [\[508\] DISA Ringing Time before Intercept](#)

- [\[509\] DISA Ringing Time after Intercept](#)

- [\[515\] Intercept Time for Internal DISA](#)

- **Related Feature References**

- Extension Hunting,

- Intercept Routing, Outgoing Message (OGM)

DISA Operation

Calling an extension by following the outgoing message

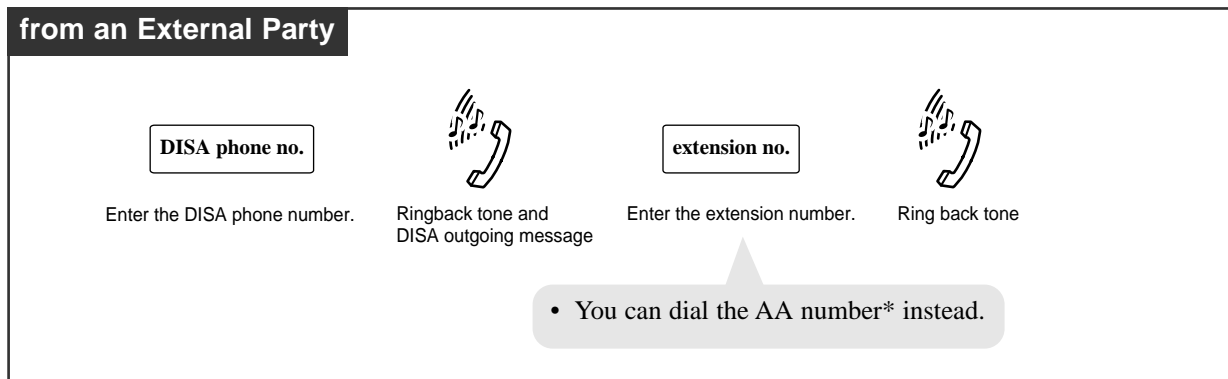

Calling an extension without an outgoing message (Internal DISA)

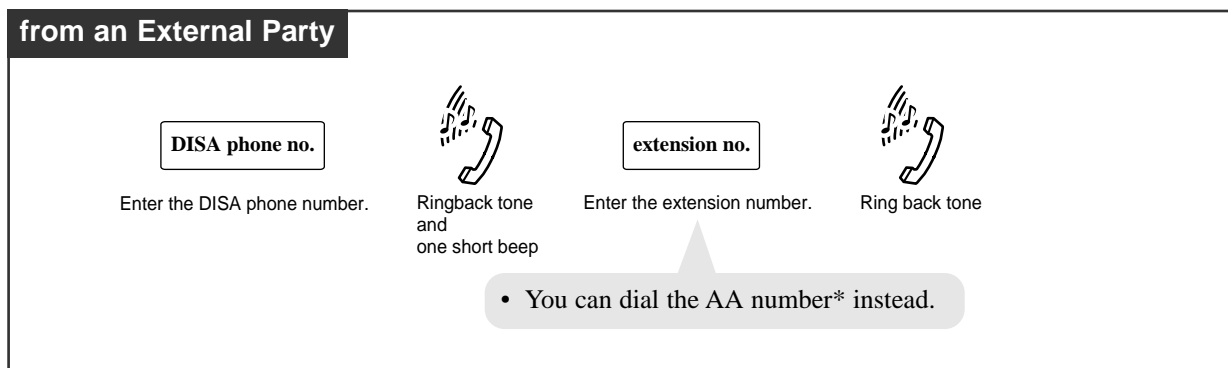

AA number*: A DISA built-in auto attendant number assigned in program [501] "DISA Built-in Auto Attendant".

Flow chart of possible cases and results for DISA calls

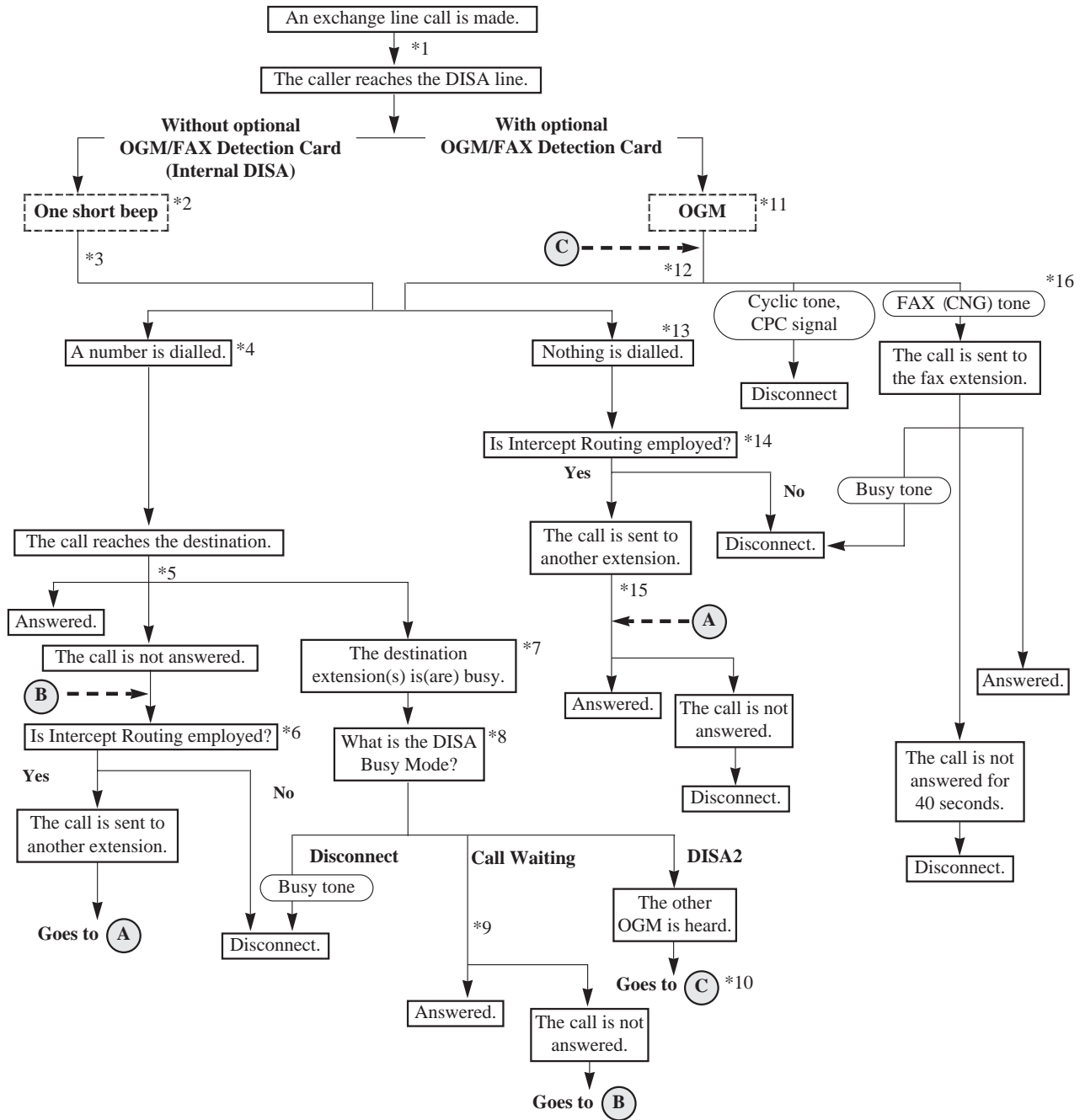

Note: The explanation for *1 through *16 is on the next page.

- *1: The DISA Delayed timer starts. This is the time between a call reaching the system and being received. The time is assigned in program [504].
- *2: When the assigned time period in program [519] expires, the system sends a short beep to the caller.
- *3: The Intercept Timer for Internal DISA starts. This is the time the system waits for the number sent by the caller. If nothing is entered by the caller during this time, the system will regard it as “Nothing is dialed.” The time is assigned in program [515].
- *4: The system can accept the following numbers:
 - **200 through 299** as an extension number.
 - **0 or 9** as the operator call number when the operator is assigned in program [008] “Operator Assignment” and “Without AA” is assigned in program [500]. Even if “With AA” is assigned, 0 or 9 is regarded as the operator call number if nothing is assigned to “0” or “9” in program [501].
 - **0 through 9** as a built-in auto attendant number when “With AA” is assigned in program [500]. The DISA AA Wait timer starts after receiving the first 1-digit number. If the timer expires, the system will assume that the first digit is an AA number. The time is assigned in program [517].
- *5: The DISA Ring Timer Before Intercept starts. The destination telephone(s) will ring for the time programmed in [508].
- *6: The system treats the call according to program [507] as follows.
 - **Disconnect** – the call is disconnected.
 - **Intercept** – the call is sent to the extensions programmed in [408]-[410] “Flexible Ringing Assignment – Day/Night/Lunch”.If the call is still not answered within the time programmed in [509], it will be disconnected.
- *7: If the destination extension belongs to a hunting group and all extensions in the group are busy, the system will check the DISA Busy Mode. If the destination is a DISA ring group, the DISA Busy Mode will not work for the call. The system regards the call as unanswered.
- *8: The DISA Busy Mode is selected in program [506]. There are 3 modes as follows.
 - **Disconnect** – the caller hears a busy tone and a call is disconnected.
 - **Call Waiting** – the destination extension hears a call waiting tone if they have enabled Call Waiting.
 - **DISA2** – if “MODE2” is assigned in program [502] and a message is recorded in OGM2, the caller will hear the message and the system waits for the new destination.

- *9: The DISA Ring Timer Before Intercept starts. The destination telephone(s) will ring for the time programmed in [508].
- *10: In this case, the system does not accept a line access code. If nothing is recorded in OGM2 or OGM2 is used for another caller, the caller will hear a busy tone and the call is disconnected.
- *11: The OGM is sent to the caller according to programs [414]–[416] and [502] when the assigned time in program [519] expires. If an OGM is not recorded, the DISA Wait Timer After OGM programmed in [505] starts immediately.
When the system detects a FAX (CNG) tone while the OGM is being sent, the call is sent to the FAX extension assigned in program [503]. When the system detects a cyclic tone or CPC signal while the OGM is being sent, the call is disconnected.
- *12: The DISA Wait Timer After OGM starts. The system waits for a number from the caller during the time assigned in program [505]. When the system detects a FAX (CNG) tone during the programmed time, the call is sent to the FAX extension. When the system detects a cyclic tone or CPC signal during the programmed time, the call is disconnected.
- *13: After the DISA Wait Timer After OGM or the Intercept Timer for Internal DISA expires, the system regards that nothing was dialed.
- *14: The system treats the call according to program [510] as follows.
 - **Disconnect** – the call is disconnected.
 - **Intercept** – the call is sent to the extensions programmed in [408]–[410]. If all extensions are assigned to “Disable”, the call will be disconnected.
- *15: The DISA Ring Timer After Intercept starts. The destination telephone(s) will ring for the time programmed in [509]. If the call is not answered during the programmed time, the call will be disconnected.
- *16: The FAX extension assigned in program [503] receives the call. When the extension is busy, the system sends a busy tone to the sending FAX. If the call is not answered after 40 seconds, the call will be disconnected.
Program [514] sets how many times the FAX (CNG) tone must be detected before the system recognises the incoming signal as facsimile data.

Display Contrast Adjustment (KX-T7130 only)

Allows a display proprietary telephone user to adjust the display contrast with the CONTRAST selector.



• Operating Instructions Reference

1.2 Proprietary Telephone Settings, “Display Contrast Adjustment”

Distinctive Dial Tones

An extension user will hear 3 types of dial tone patterns which give information about the features activated on the telephone.

Dial Tone 1: This is a normal dial tone. None of the features listed in Dial Tone 2 are activated.

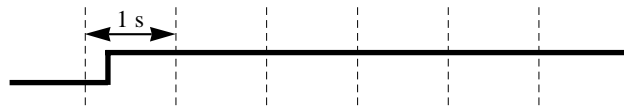

Dial Tone 2: Sent when any of the following features are set.

- Absent Message Capability
- Call Forwarding
- Data Line Security
- Electronic Extension Lockout
- Pickup Dialling
(for single line telephones only)
- Timed Reminder
- Background Music (BGM)
(for proprietary telephones only)
- Call Pickup Deny
- Do Not Disturb (DND)
- Message Waiting
(for proprietary telephones only)
- Remote Extension Lock Control



Dial Tone 3: Sent when making an Account Code Entry and answering a Timed Reminder call. Also sent when going off-hook with a single line telephone which has a message in a Voice Processing System.



• Operating Instructions Reference

1.7 Useful Features, “Distinctive Dial Tones”

Do Not Disturb (DND)

<Do Not Disturb (DND)>

Allows an extension user to prevent other parties from disturbing them. The extension will not receive intercom or outside calls.

<Do Not Disturb (DND) Override>

Allows an extension user enabled in program [609] to call an extension which has set the Do Not Disturb (DND) feature.



- If your proprietary telephone (PT) is not supplied with the FWD/DND button, it can be assigned to a flexible line key in the Proprietary Telephone Settings.
- DND does not work for the following calls: Hold recall or Timed Reminder.
- A PT user in the DND mode can answer a call by pressing the corresponding flashing button.
- If the Call Forwarding feature has already been set, setting the DND feature will cancel Call Forwarding.



- **Required System Programming**
[609] Do Not Disturb Override

- **Related Feature References**

Call Forwarding,
Timed Reminder

- **Operating Instructions References**

1.2 Proprietary Telephone Settings,
“Customising the Buttons on
Your Telephone”,
FWD/DND (Forward/Do Not Disturb) Button

1.7 Useful Features, “Rejecting Incoming Calls (Do Not Disturb — DND)”

1.7 Useful Features, “Calling an Extension which Denies Receiving Calls
(Do Not Disturb Override)”

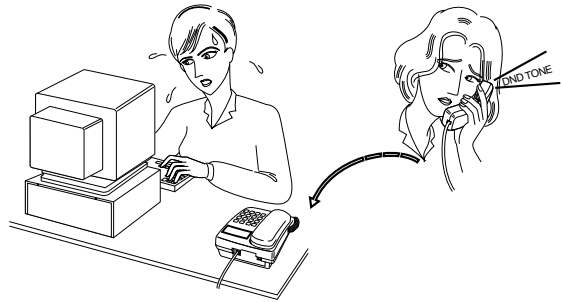

Door Opener

Up to 4 Door Openers can be connected to the system. The door can be unlocked by a pre-assigned extension users in programs [703]-[705].

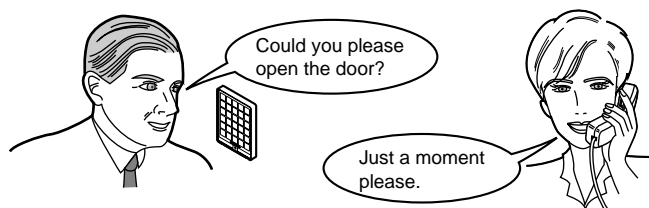

- An optional Doorphone/Door Opener Card must be installed to the system and a user-supplied door opener to the door to be opened. Four openers can be installed.
- The door opener will open the door even if a doorphone is not installed.
- The door opener timer can be modified in program [709].



- **Connection Reference**
2.16 Doorphone and Door Opener Connection
- **Required System Programming**
[\[703\]-\[705\] Door Opener Assignment — Day/Night/Lunch](#)
[\[709\] Door Opener Time](#)
- **Related Feature Reference**
Doorphone Call
- **Operating Instructions Reference**
1.7 Useful Features, “Door Opener”

Doorphone Call

Up to 4 Doorphones (KX-T30865) can be installed. If a visitor presses the doorphone button, a pre-assigned extension user in programs [700]-[702] can answer the call and talk to the visitor. Any extension user can call a doorphone. The doorphones are also used for the Room Monitor feature.



- An optional Doorphone/Door Opener Card must be installed to the system and a doorphone. Four doorphones can be installed.
- Doorphone 1 and 2 cannot be used simultaneously. When one is in use, an extension user cannot have a conversation with the other. Doorphone 3 and 4 are the same.
- An access tone can be programmed in [707] to be sent to a monitored doorphone before room monitoring starts.
- The ring tone from the doorphone call is programmable in [706].



- **Connection Reference**
 - 2.16 Doorphone and Door Opener Connection
- **Required System Programming**
 - [\[700\]–\[702\] Doorphone Ringing Assignment — Day/Night/Lunch](#)
 - [\[706\] Doorphone Ringing/Tone Pattern Selection](#)
 - [\[707\] Doorphone Access Tone Selection](#)
 - [\[708\] Doorphone Ringing Time](#)
- **Related Feature References**
 - Door Opener, Room Monitor
- **Operating Instructions References**
 - 1.7 Useful Features, “Room Monitor”
 - 1.7 Useful Features, “Doorphone Call”

DSS Console

The Direct Station Selection (DSS) Console provides direct access to extensions, a busy lamp display, as well as 16 PF (Programmable Feature) buttons.

The DSS Console must be programmed to work with a proprietary telephone (PT). The port number of the DSS Console and its associated PT are assigned in programs [003] and [004].

Up to 2 consoles can be installed per system.

If a feature like One-Touch Dialling is assigned to a DSS button or PF button, accessing the feature can be done easily by pressing the corresponding button. This is very useful for an operator or manager. Refer to the Operating Instructions for more details.



- Programming the DSS and PF buttons can be done only from the paired telephone.
- Indicating the Forward (FWD) or Do Not Disturb (DND) status of corresponding extensions using a DSS button indication is programmable in [112].



- **Connection Reference**
 - 2.8 Extension Connection
- **Required System Programming**
 - [\[003\] DSS Console Port Assignment](#)
 - [\[004\] Paired Telephone Assignment for DSS Console](#)
 - [\[112\] DSS Console Indication Mode](#)
- **Operating Instructions Reference**
 - 1.9 DSS Console Features

Emergency Call

Allows an extension user to access a pre-assigned emergency number which can be dialled regardless of any restrictions.



- Up to 5 emergency numbers can be stored.
- An emergency call is allowed even in the following cases;
 - in Account Code Modes (Verify–All and Forced modes),
 - in any call barring COS number, and
 - in Electronic Extension Lockout.



- **Required System Programming**
[\[309\] Emergency Dial Number Set](#)
- **Related Feature References**
Account Code Entry, Call Barring, Extension Lock
- **Operating Instructions Reference**
1.3 Making Calls, “Making Emergency Calls (Emergency Call)”

Exchange Line Ringing Selection

When an outside call is received at an extension, the user can select whether their extension will ring or not.



- Select “Enable” in programs [408]–[410].



- **Required System Programming**
[\[408\]–\[410\] “Flexible Ringing Assignment — Day/Night/Lunch](#)
- **Operating Instructions Reference**
1.2 Proprietary Telephone Settings, “Customising Your Telephone Functions”,
Exchange Line Ringing Selection

Executive Busy Override

<Executive Busy Override – Extension>

Allows an extension user enabled in program [608] to interrupt an existing intercom call. A 3-party conference will be established.

<Executive Busy Override – Exchange Line>

Allows a proprietary telephone user enabled in program [608] to interrupt an existing outside call or add a third party. A 3-party conference will be established.

<Executive Busy Override Deny>

Allows an extension user to prevent other extension users from interrupting their conversation.



- The Executive Busy Override feature will not work if the extension engaged the conversation has set Executive Busy Override Deny or Data Line Security.
- When a 3-party call is changed to a 2-party call or vice versa, a confirmation tone will be sent to all parties. This tone can be disabled by program [105].



- **Required System Programming**

- [\[105\] Conference Tone](#)

- [\[608\] Executive Busy Override](#)

- **Related Feature Reference**

- Conference (3-party)

- **Operating Instructions References**

- 1.3 Making Calls, “Interrupting an Existing Call (Executive Busy Override)”

- 1.3 Making Calls, “Denying ‘Interrupting an Existing Call’ (Executive Busy Override Deny)”

Extension Button Confirmation

(KX-T7130 only)

Allows a display proprietary telephone user to confirm the values stored in the buttons, such as the REDIAL button or flexible line key, by pressing the corresponding button while on-hook.



- **Operating Instructions Reference**

- 1.7 Useful Features “Extension Button Confirmation (KX-T7130 only)”

Extension Feature Clear

Allows an extension user to reset the following extension features to the default settings.

- Absent Message Capability
- Automatic Callback Busy (Camp-On)
- Background Music (BGM)
- Call Forwarding
- Call Pickup Deny
- Call Waiting
- Data Line Security
- Do Not Disturb (DND)
- Executive Busy Override Deny
- Log-In/Log-Out
- Message Waiting – (All messages will be erased.)
- Pickup Dialling – (The stored telephone number will be erased.)
- Paging Deny
- Room Monitor
- Timed Reminder
- Voice Mail Integration



- **Operating Instructions Reference**

- 1.7 Useful Features, “Cancelling the Feature Settings (Extension Feature Clear)”

Extension Group

The system supports 8 extension groups. In an extension group, the following features can be activated.

- **Group Call Pickup:** Any member of an extension group can pick up a call directed to another member in the same group.
- **Paging – Group:** Any member of an extension group can make a voice announcement to another group member.

A hunting group, DISA ring group or UCD group is a specific extension group. The following operation as well as the features above can be activated for a hunting group, DISA ring group or UCD group.

Hunting Group

An extension group enabled in program [100] “Hunting Group Set” will perform the Extension Hunting feature. See “Extension Hunting” in this section.

DISA Ring Group

All extensions in a DISA ring group assigned as an auto attendant destination in program [501] “DISA Built-in Auto Attendant” will ring simultaneously. Selecting “DISA1” or “DISA2” in programs [414]–[416] “Exchange Line Mode — Day/Night/Lunch” is required. Also, you must select “With AA” in program [500] “DISA Incoming Dialling Mode Selection”.

UCD Group

One extension group assigned as the UCD group in program [520] “UCD Group” can be the destination of incoming outside calls via the UCD feature. Selecting “UCD” in programs [414]–[416] “Exchange Line Mode — Day/Night/Lunch” is required.



- **Required System Program Address**
[\[600\] Extension Group Assignment](#)

- **Related Feature References**

Call Pickup, Direct Inward System Access (DISA), Extension Hunting, Paging, Uniform Call Distribution (UCD)

Extension Hunting

If a called extension is busy, Extension Hunting redirects the incoming call to an idle extension in an extension group in numerical order. Idle extensions are automatically hunted according to programming. The following 2 hunting types are available.

- Circular hunting:** The extensions are hunted one time in numerical order. If all extensions are busy, a busy tone will be heard.
- Terminate hunting:** The extensions are hunted until the extension which has the highest port number in the group is reached. If all higher order numbers are busy, the search will end and a busy tone will be heard.



- One hunting type can be selected for each extension group.
- To leave the hunting group temporarily, use the Log-Out feature. To rejoin, use the Log-In feature.
- If the called extension has set Do Not Disturb (DND), Call Forwarding or Log-Out, Extension Hunting will skip the extension. However, Extension Hunting will not skip the extension which receives the call first, even if it has set Do Not Disturb (DND) or Call Forwarding.



- **Required System Programming**
 - [\[100\] Hunting Group Set](#)
 - [\[101\] Hunting Type](#)
 - [\[600\] Extension Group Assignment](#)
- **Related Feature References**
 - Call Forwarding
 - Do Not Disturb (DND)
 - Extension Group
 - Log-In/Log-Out

Circular Hunting

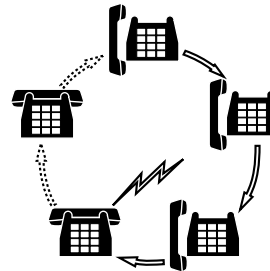

Terminate

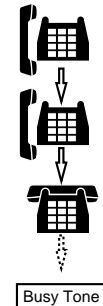

Extension Lock

<Electronic Extension Lockout>

Allows an extension user to lock their extension so that other users cannot make outside calls until it is unlocked. Any 4-digit code can be used to lock and unlock an extension.

<Electronic Extension Lockout – CANCEL ALL>

The operator and manager can cancel Electronic Extension Lockout of all extensions at one time.

<Remote Extension Lock Control>

The operator and manager are given the privilege of controlling Electronic Extension Lockout at any extension by using the DSS console. The operator and manager can see the status of each extension, locked or unlocked, by the pre-assigned DSS button LED on the DSS console. For example, this feature is useful for a small hotel or motel when guests are checked out.

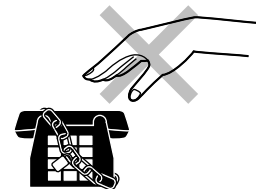



- The Remote Extension Lock Control overrides the Electronic Extension Lockout. If the operator or manager sets Remote Extension Lock on an extension that has already been locked by the extension user, the user cannot unlock it.
- A call barring class can be assigned to an extension which has set the Electronic Extension Lockout and Remote Extension Lock Control features in program [312] “Call Barring – Extension Lock Boundary Class”. Certain types of outgoing outside calls are allowed depending on the assigned call barring class.



- **Operating Instructions References**

- 1.6 Before Leaving Your Desk, “Locking Your Telephone (Electronic Extension Lockout)”
- 1.8 Operator / Manager Service Features, “Electronic Extension Lockout – CANCEL ALL”
- 1.8 Operator / Manager Service Features, “Remote Extension Lock”
- 1.9 DSS Console Features “Initial Settings”, Extension Lock Button Assignment (Operator/Manager only)

Extension Password / System Password

The extension password assigned by the manager (extension port 01) to each extension can be used for the Walking COS feature.

The system password is used for entering System Programming and also before assigning the extension password.



- **Required System Programming**

- [\[002\] System Password](#)

- **Related Feature References**

- Walking COS

- **Operating Instructions Reference**

- 1.8 Operator / Manager Service Features, “Extension Password Set (Manager only)”

External Feature Access

Allows an extension user to access special features (e.g. Call Waiting) offered by the Local Exchange or host PBX. This is done by placing the current call on hold and sending a recall signal using either the RECALL button or the feature number. This feature is effective only during an outside call.



- When “MODE2” is selected in program [110] and the RECALL button is pressed for longer than the time programmed in [418], this feature will not work.
- The recall time must be assigned in program [418] as required by the host PBX or exchange line.



- **Required System Programming**
 - [\[110\] Recall Key Mode](#)
 - [\[418\] Recall Time](#)
- **Related Feature References**
 - Host PBX Access, Recall
- **Operating Instructions Reference**
 - 1.7 Useful Features, “External Feature Access”

Flexible Buttons

A proprietary telephone (PT) user can change the flexible buttons on the telephone and DSS console to certain function buttons. For example, if the telephone has more line keys than available exchange lines, the unused line keys may be changed to One-Touch Dialling buttons, etc.

The 4 types of flexible buttons are as follows:

- **Flexible line keys** (located on a PT only)
- **Flexible DSS Buttons** (located on a DSS Console only)
- **Programmable Feature (PF) Buttons** (located on a PT and DSS Console)
- **Flexible MESSAGE Buttons**

Check the required operation first. If the telephone is not provided with the button, assigning the button can be performed in the Proprietary Telephone Settings.

| Function | Programmable Button | | | |
|----------------------------------|---------------------|-----|----|---------|
| | LINE | DSS | PF | MESSAGE |
| DSS (Direct Station Selection) | ✓ | ✓ | | ✓ |
| One-Touch Dialling | ✓ | ✓ | ✓ | ✓ |
| CONF (Conference) | ✓ | | | |
| FWD/DND (Forward/Do Not Disturb) | ✓ | | | |
| SAVE | ✓ | | | |
| Log-In/Log-Out | ✓ | | | |
| Single Exchange Line (S-CO) | ✓ | | | |
| Other Exchange Line (O-CO) | ✓ | | | |
| Trunk Group (G-CO) | ✓ | | | |
| MESSAGE (Message Waiting) | | | | ✓ |
| Day | | ✓ | | |
| Night | | ✓ | | |
| Lunch | | ✓ | | |
| Extension Lock | | ✓ | | |

“✓” indicates that the feature is available.



- **Operating Instructions Reference**
1.2 Proprietary Telephone Settings, “Customising the Buttons on Your Telephone”

Handsfree Answerback

Allows a proprietary telephone with a speakerphone to answer an intercom call without lifting the handset. This feature performed by pressing the AUTO ANSWER/MUTE button.



- This feature does not work for incoming outside calls or doorphone calls.



- **Operating Instructions Reference**
1.4 Receiving Calls, “Handsfree Answerback”

Handsfree Operation

Allows a proprietary telephone user to dial and talk to the other party without lifting the handset. Pressing one of the following buttons activates the handsfree mode when the SP-PHONE/MONITOR button indicator is off:

SP-PHONE button, MONITOR button, INTERCOM button, or line key.



- The KX-T7050 can perform handsfree dialling operations, etc., but cannot have a handsfree conversation.



- **Operating Instructions Reference**
1.3 Making Calls, “Handsfree Operation”

Hold

<Call Hold>

Allows an extension user to place an intercom and/or outside call on hold. The held call can be retrieved by the user who held it, or by any other extension (Call Hold Retrieve).

With a single line telephone (SLT), either one outside or intercom call can be held at one time. If an SLT user wants to hold both calls, use the Call Park feature. An SLT user can select how to operate the Call Hold feature by program [104].

<Exclusive Hold>

Allows a proprietary telephone user to prevent other extension users from retrieving their held call. Only the user who held the call can retrieve it. This feature is not available for an SLT.



- Only one intercom call can be placed on hold. For a proprietary telephone, outside calls and one intercom call can be placed on hold at the same time.
- If a held call is not retrieved within the assigned time in program [200], the extension user who held it will hear a ring tone or an alarm tone. If the user is on-hook and their SP-PHONE/MONITOR button indicator is off, the phone will ring (Hold Recall). If the user is off-hook or in the handsfree mode, an alarm tone will be sent to the built-in speaker of a proprietary telephone or the handset receiver of a single line telephone at 15-second intervals (Hold Alarm). If “Disable” is selected in program [200], nothing will be heard.
- If a held outside call is not answered within thirty minutes, it will be automatically disconnected.
- For outside calls, music is sent to the external party on hold, if available (Music on Hold).
- During a 5-party conference, the Hold feature cannot be activated.



- **Required System Programming**

- [\[104\] Hold Mode Selection](#)

- [\[200\] Hold Recall Time](#)

- **Related Feature References**

- Call Park, Music on Hold/Background Music (BGM),
Recall Button on a Single Line Telephone

- **Operating Instructions References**

- 1.5 During a Conversation, “Placing a Call on Hold (Call Hold)”

- 1.5 During a Conversation, “Placing a Call on Hold Exclusively (Exclusive Hold)”

- 1.5 During a Conversation, “Retrieving a Call on Hold (Call Hold Retrieve)”

Host PBX Access

The system may be installed behind an existing host PBX. This is performed by connecting a line from the host to an exchange line in the system.



- A Host PBX Access code assigned in program [403] is required to access an exchange line of the host PBX.
- Access to the host PBX during a conversation is also possible (External Feature Access).



- **Required System Programming**

- [\[403\] Host PBX Access Codes](#)

- [\[417\] Pause Time](#)

- **Related Feature Reference**

- External Feature Access

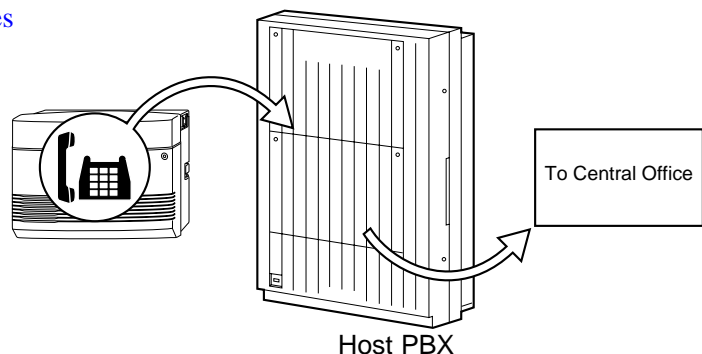

Intercept Routing

Provides automatic redirection of incoming outside calls via the DISA or UCD feature. The Intercept Routing feature works in the following 2 cases.

- 1) When nothing is dialed after a dial tone or OGM is sent to the caller. (The DISA feature only)
- 2) When the call is not answered within a programmed time. This is called Intercept Routing – No Answer (IRNA).



- **Required System Programming**

- [408]–[410] Flexible Ringing Assignment — Day/Night/Lunch
- [507] DISA Intercept Mode
- [508] DISA Ringing Time before Intercept
- [509] DISA Ringing Time after Intercept
- [510] DISA No Dial Mode
- [523] UCD Busy Mode
- [524] UCD Intercept Mode
- [525] UCD Ringing Time before Intercept
- [526] UCD Ringing Time after Intercept

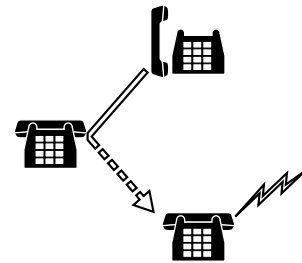

- **Related Feature References**

Direct Inward System Access (DISA), Uniform Call Distribution (UCD)

Intercom Calling

Allows an extension user to make a call to another extension.



- An extension number and a name can be assigned in programs [009] and [604]. If assigned, they will be shown on the display proprietary telephone during an intercom call.
- The DSS buttons permit a proprietary telephone user one-touch access to an extension. The DSS function can be assigned to a flexible line key in the Proprietary Telephone Settings. The DSS buttons on the DSS console can also be used.
- An extension user can press the DSS buttons directly to make an intercom call without going off-hook. This can be enabled by program [126].



- **Required System Programming**

- [009] Extension Number Assignment
- [126] DSS Off-Hook Mode
- [604] Extension Name Setting

- **Operating Instructions References**

- 1.2 Proprietary Telephone Settings, “Customising the Buttons on Your Telephone”, DSS (Direct Station Selection) Button
- 1.3 Making Calls, “Intercom Calling”
- 1.9 DSS Console Features, “Initial Settings”, Extension Number Assignment

Language Selection

The selected language in program [615] is shown on the LCD display of a proprietary telephone during operation and Proprietary Telephone Settings, but not used during System Programming. The selected language in program [806] is used for an SMDR printout.



- **Required System Programming**
 - [\[615\] LCD Language Assignment](#)
 - [\[806\] SMDR Language Assignment](#)

Limited Call Duration

The system disconnects outside outgoing calls when a specific timer expires. The timer is in effect when making an outside call, transferring an intercom call to an exchange line or forwarding an intercom call to an exchange line. Limiting the time of the call can be assigned through System Programming.



- An alarm tone will be sent to both parties 15 seconds before the assigned time limit.



- **Required System Programming**
 - [\[212\] Exchange line Duration Time Limit](#)
 - [\[613\] Exchange line Duration Time Limit Selection](#)
- **Related Feature References**
 - Call Forwarding, Call Transfer – to Exchange line

Line Access Keys

A proprietary telephone (PT) user must assign one of the following 3 types of line keys to flexible line keys in the Proprietary Telephone Settings. This permits making or receiving outside calls. The default setting for the flexible line keys (CO 1 – CO 6) are Single Exchange Line (S-CO) keys. CO 1 corresponds to exchange line 1, CO 2 corresponds to exchange line 2, etc.

<Trunk Group (G-CO) Key>

Receiving or making outside calls is on a trunk group basis. The trunk group is assigned in program [404]. Any incoming call from any exchange line in the trunk group arrives at the G-CO key. To make an outside call, the user can access an idle exchange line in the group by simply pressing the assigned G-CO key.

<Single Exchange Line (S-CO) Key>

Receiving or making outside calls is done using a specific exchange line. An incoming call from the specific exchange line arrives at the S-CO key. To make an outside call, the user can access the specific exchange line by simply pressing the assigned S-CO key.

<Other Exchange Line (O-CO) Key>

Exchange lines, which are not assigned to an S-CO or G-CO key, can be assigned to a flexible line key as the O-CO key. An incoming call on an exchange lines arrives at the O-CO. To make an outside call, the user simply presses the assigned O-CO key.



- The same trunk group can be assigned to more than one G-CO key on the same PT.
- The same line can be assigned to an S-CO key and G-CO key. The S-CO key has priority.
- Immediate, delayed, no ringing or no incoming calls (disable) can be selected by programs [408] through [413] on an extension-exchange line basis.
- A ringing pattern can be selected for each exchange line by program [423].



- **Required System Programming**

- [400] Exchange Line Connection Assignment
- [404] Trunk Group Assignment
- [405]–[407] Flexible Outward Dialling Assignment — Day/Night/Lunch
- [408]–[410] Flexible Ringing Assignment — Day/Night/Lunch
- [411]–[413] Delayed Ringing Assignment — Day/Night/Lunch
- [423] Exchange Line Ringing Pattern Selection

- **Related Feature References**

Outside Calling, Receiving Calls, Ringing Pattern Selection

- **Operating Instructions Reference**

1.2 Proprietary Telephone Settings, “Customising the Buttons on Your Telephone”,
Line Access Keys

Log-In/Log-Out

Allows an extension user to Log-In (join) or Log-Out (leave) a hunting, DISA ring or UCD group temporarily. Extensions in the log-out mode will not receive calls by Extension Hunting, DISA or UCD but will receive other calls, not like the Do Not Disturb (DND) feature. The Log-In/Log-Out button can be assigned to a flexible button in the Proprietary Telephone Settings. The lighting patterns of the Log-In/Log-Out button on a proprietary telephone and status are as follows.

Off: Log-In mode
Red: Log-Out mode



- There should be at least one extension that is in the Log-In mode in a group.



- **Related Feature References**

Direct Inward System Access (DISA),
Extension Group,
Extension Hunting, Uniform Call Distribution (UCD)

- **Operating Instructions References**

1.2 Proprietary Telephone Settings, “Customising the Buttons on Your Telephone”,
Log-In/Log-Out Button
1.7 Useful Features, “Joining or Leaving a Call Distribution Group (Log-In/Log-Out)”

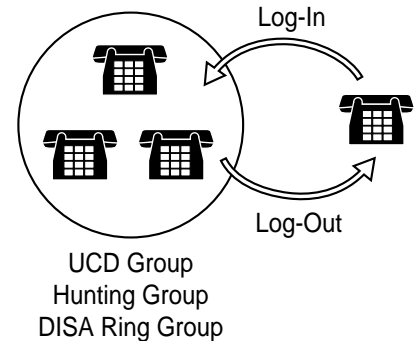

Message Waiting

Allows an extension user to notify the called extension of a message waiting when the called extension is busy or does not answer the call. Only a proprietary telephone user with a MESSAGE button can know there is a message waiting if the LED on the MESSAGE button lights red. Pressing the lit MESSAGE button will reply to the message by calling the extension which left the message. The messages which are stored in the mailbox of the Voice Processing System can also be heard by following the Voice Mail prompts after pressing the lit MESSAGE button (Voice Mail Integration).



- Cancelling the message can be performed from the extension sending it or from the extension receiving it.
- Each extension can have a maximum of 8 simultaneous messages.
- Messages are always left at the original extension. They cannot be sent to a Call Forwarding or Extension Hunting destination.



- **Operating Instructions References**

- 1.2 Proprietary Telephone Settings, “Customising the Buttons on Your Telephone”, Restoring the MESSAGE button
- 1.7 Useful Features, “Leaving a Message Notification (Message Waiting)”
- 1.7 Useful Features, “Voice Mail Integration for KX-TVP100”

Microphone Mute

Allows a proprietary telephone user to turn off the microphone for privacy.



- The user’s voice will only be muted during a handsfree conversation. The user can hear the other party’s voice during Microphone Mute.



- **Operating Instructions Reference**

- 1.5 During a Conversation, “Turning off the Microphone (Microphone Mute)”

Music on Hold / Background Music (BGM)

While an external party is on hold, music is automatically generated.



- Operations such as Call Hold and Call Transfer activate Music on Hold.
- A user-supplied external music source, such as a radio, must be connected to the system when “External” is selected in program [111]. One external music source can be connected to the system. The music source is used for Music on Hold and/or BGM.
- When “Tone” is selected in program [111], the cyclic tone is used only for Music on Hold and the external music source is used for BGM.



- **Connection Reference**
2.10 External Music Connection
- **Required System Programming**
[\[111\] Hold Music Selection](#)
- **Related Feature References**
Hold, Call Transfer – to Exchange line, Call Transfer – to Extension, Uniform Call Distribution (UCD)
- **Operating Instructions Reference**
1.7 Useful Features, “Turning on the Background Music (BGM)”

One-Touch Dialling

Allows a proprietary telephone user one-touch access to a desired party or system feature. This is done by storing an extension number, telephone number or a feature number (up to 24 digits) in a One-Touch Dialling button. One-Touch Dialling buttons can be assigned to flexible buttons in the Proprietary Telephone Settings.



- An account code can be stored into a One-Touch Dialling button.
- A number consisting of 25 digits or more can be stored by dividing it and storing it in 2 One-Touch Dialling buttons.



- **Operating Instructions References**
1.2 Proprietary Telephone Settings, “Customising the Buttons on Your Telephone”
One-Touch Dialling button
1.3 Making Calls, “Dialling by Simply Pressing a Button (One-Touch Dialling)”
1.9 DSS Console Features, “Initial Settings”
1.9 DSS Console Features, “One-Touch Dialling”
1.9 DSS Console Features, “One-Touch Access for System Features”

Operator / Manager Extension

The system supports one operator. Any extension can be designated as an operator in program [008]. Extension port 01 is the system manager extension. The extension assigned as an operator or manager has the ability to perform the following operations.

- Setting the Date and Time
- Cancelling the Electronic Extension Lockout
- Setting/Cancelling the Remote Extension Lock
- Setting/Cancelling/Confirming the Timed Reminder (Wake-up Call) Remotely
- Recording and Playing the Outgoing Message
- Changing the Day/Night/Lunch Mode

The manager extension can also perform System Programming and the following operation.

- Setting the Extension Password



- **Required System Programming**
[\[008\] Operator Assignment](#)
- **Operating Instructions Reference**
1.8 Operator / Manager Service Features

Operator Call

Allows an extension user to call an operator within the system by dialling the feature number assigned in program [121]. One extension can be assigned as the operator in program [008].



- If an operator is not assigned, this feature is not available and a reorder tone will be heard.
- Every extension user can reach the operator just by dialling the operator call number (0 or 9) assigned in program [121] “Automatic Exchange Line Access Number Selection”.



- **Required System Programming**
[\[008\] Operator Assignment](#)
[\[121\] Automatic Exchange Line Access Number Selection](#)
- **Related Feature Reference**
Automatic Exchange Line Access Number
- **Operating Instructions Reference**
1.3 Making Calls, “Calling an Operator (Operator Call)”

Outgoing Message (OGM)

Allows the extension assigned as an operator or manager to record up to 2 outgoing voice messages (maximum 30 seconds each). This message is played when a caller accesses the DISA or UCD feature. An optional OGM/FAX Detection Card is required to program the OGM.

The following are some examples of OGM and flow chart.

Case 1: Receives 2 calls at a time – OGM for DISA.

(Do not want customers to be kept waiting.)

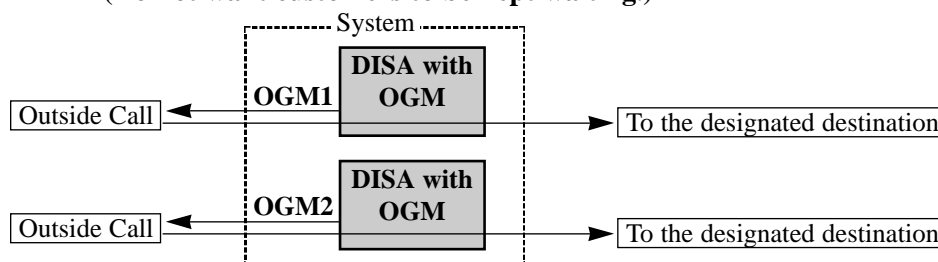

OGM1: “This is A company. For the sales division, press 1. For the service division, press 2. To call the operator, press 0.”

OGM2: Same as OGM 1

Required Settings: [502] “MODE1”
[414]-[416] “DISA1”

Case 2: Uses the OGM in the day, night and lunch modes – OGM for DISA.

(In the day mode)

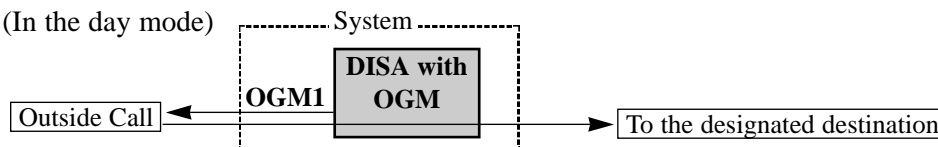

(In the night mode)

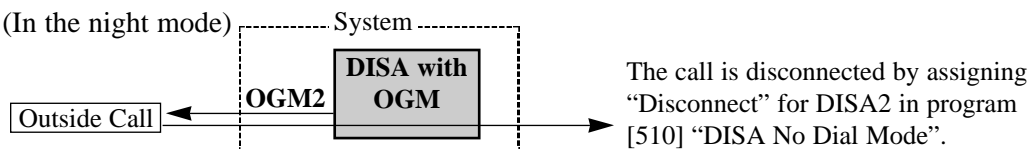

OGM1: “This is A company. For the sales division, press 1. For the service division, press 2. To call the operator, press 0.”

OGM2: “We are sorry but our office is closed for the day.”

Required Settings: [502] “MODE2”
[414]-[416] “DISA1” for OGM1, “DISA2” for OGM2

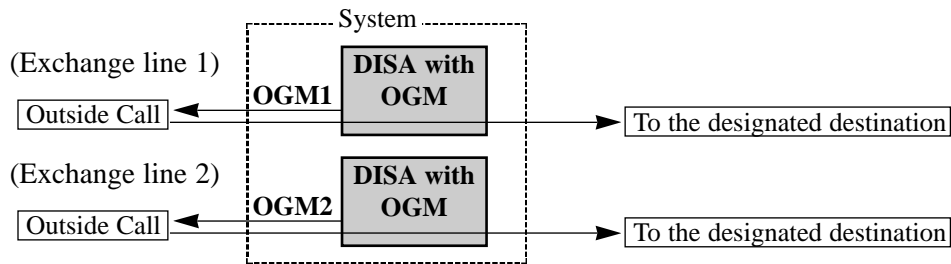
Case 3: Uses a different OGM for exchange lines – OGM for DISA.

OGM1: “This is A company. For the sales division, press 1. For the service division, press 2. To call the operator, press 0.”

OGM2: “This is B company. To contact Mr. A, press 101. To contact Mr. B, press 102.”

Required Settings: [502] “MODE2”

[414]-[416] “DISA1” for the A company exchange line(s).

“DISA2” for the B company exchange line(s).

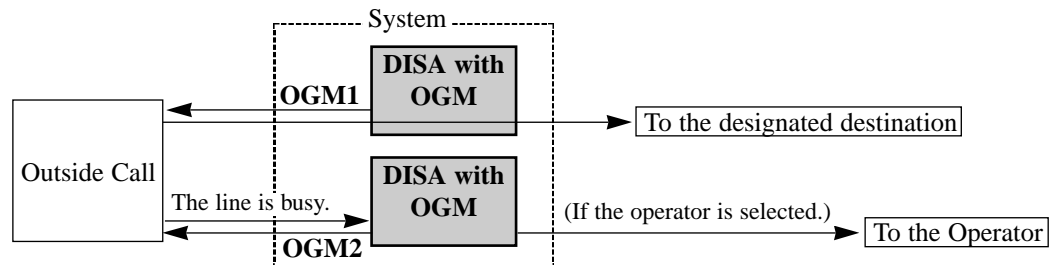
Case 4: Uses a different OGM when the line is busy – OGM for DISA.

OGM1: “This is A company. For the sales division, press 1. For the service division, press 2. To call the operator, press 0.”

OGM2: “We are sorry. The line is currently busy. If you want to call the operator, press 0.”

Required Settings: [502] “MODE2”

[414]-[416] “DISA1”

[506] “DISA2”

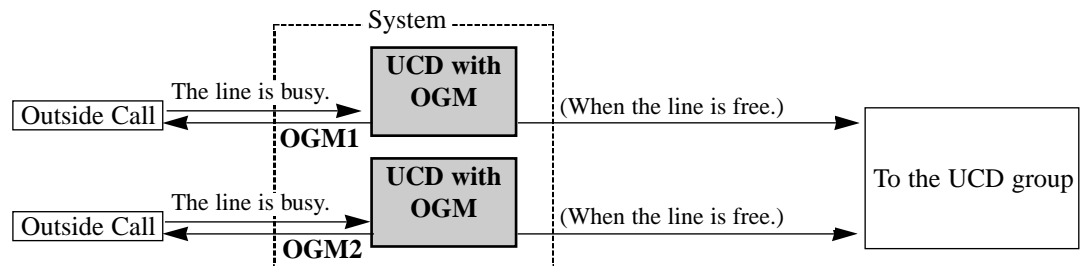
Case 5: Distributes calls to the UCD group – OGM for UCD.

OGM1: “We are sorry. The line is currently busy. Please hold.”

OGM2: Same as OGM1

Required Settings: [502] “MODE3”

[414]-[416] “UCD”

Case 6: Disconnects a call after the OGM – OGM for UCD.

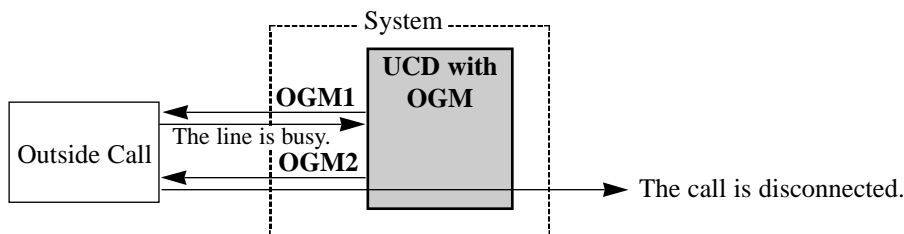

OGM1: “We are sorry. The line is currently busy. Please hold.”

OGM2: “We are sorry. The line is currently busy. Please call back later.”

Required Settings: [502] “MODE4”
[414]-[416] “UCD”

Case 7: Uses the DISA or UCD feature for exchange lines – OGM for DISA and UCD.

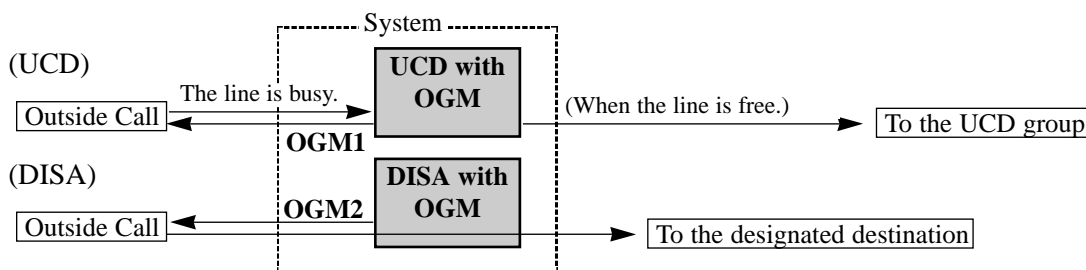

OGM1: “We are sorry. The line is currently busy Please hold.” (UCD message)

OGM2: “This is A company. For the sales division, press 1. For the service division, press 2. To call the operator, press 0.” (DISA message)

Required Settings: [502] “MODE5”
[414]-[416] “DISA1” for exchange line(s) which use the DISA feature
“UCD” for exchange line(s) which use the UCD feature

Case 8: Uses the DISA feature when none of the extension in the UCD group can answer a call – OGM for UCD.

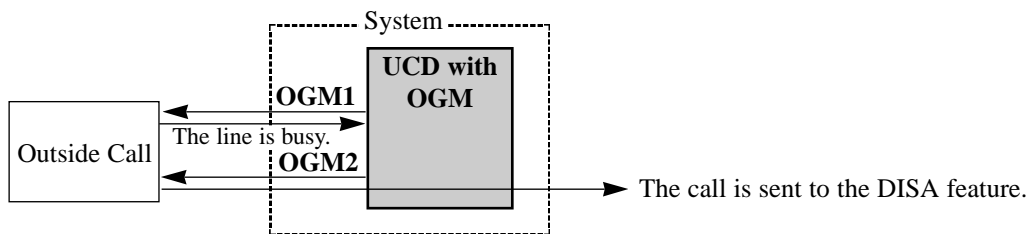

OGM1: “We are sorry. The line is currently busy Please hold.”

OGM2: “This is A company. For the sales division, press 1. For the service division, press 2. To call the operator, press 0.”

Required Settings: [502] “MODE6”
[414]-[416] “UCD”
[523] “Intercept”



- An optional OGM/FAX Detection Card is required to program the OGM.



- **Connection Reference**

- 2.15 OGM/FAX Detection Card Installation

- **Required System Programming**

- [\[414\]–\[416\] Exchange Line Mode — Day/Night/Lunch](#)

- [\[502\] OGM Mode Selection](#)

- [\[506\] DISA Busy Mode](#)

- [\[523\] UCD Busy Mode](#)

- **Related Feature References**

- Direct Inward System Access (DISA), Uniform Call Distribution (UCD)

- **Operating Instructions Reference**

- 1.8 Operator / Manager Service Features, “Outgoing Message (OGM)”

Outside Calling

Allows an extension user to make a call to an external party by using one of the following line access methods.

<Automatic Line Access>

Allows an extension user to select an available exchange line automatically from the assigned lines in program [419] by pressing the Automatic Line Access number (0 or 9). For a proprietary telephone, a Line Access Key assignment (S-CO, G-CO, O-CO) in the Proprietary Telephone Settings is required. If Idle Line Preference is set on the telephone in the Proprietary Telephone Settings, the user can access an idle line only by going off-hook.

<Individual Line Access>

Allows a proprietary telephone user to select the desired exchange line by pressing the line key assigned as the S-CO key. A Line Access Key assignment (S-CO) is required before use.

<Trunk Group Access>

Allows an extension user to select an idle line within a designated trunk group. A trunk group is assigned in program [404]. To specify a trunk group, dial the feature number “8” and the desired trunk group number (1 through 6). A proprietary telephone user can also specify a trunk group by pressing a G-CO key. A Line Access Key assignment (G-CO) is required before use. If Idle Line Preference is set on the telephone in the Proprietary Telephone Settings, the user can access an idle line only by going off-hook.



- Each extension requires System Programming to access exchange lines.
- After an exchange line is seized, the system waits for the assigned time in program [206] before dialling.



- **Required System Programming**

- [\[206\] Dialling Start Time](#)

- [\[400\] Exchange Line Connection Assignment](#)

- [\[404\] Trunk Group Assignment](#)

- [\[405\]–\[407\] Flexible Outward Dialling Assignment — Day/Night/Lunch](#)

- [\[419\] Automatic Designated Exchange Line Access](#)

- **Related Feature References**

- Automatic Exchange Line Access Number

- Preferred Line Assignment — Outgoing, Line Access Keys

- **Operating Instructions References**

- 1.2 Proprietary Telephone Settings, “Customising Your Telephone Functions”, Preferred Line Assignment — Outgoing

- 1.2 Proprietary Telephone Settings, “Customising the Buttons on Your Telephone”, Line Access Keys

- 1.3 Making Calls, “Outside Calling”

Paging

Allows an extension user to make a voice announcement to several people at the same time. The message is announced over the built-in speakers of proprietary telephones and/or the external pager. The paged person can answer the page (Answering a Page) from any extension within the system. The following types are available.

- All Extensions:** Makes a voice announcement to all extensions over the built-in speakers of proprietary telephones.
- Group:** Makes a voice announcement to the designated extension group over the built-in speakers of proprietary telephones. An extension group is assigned in program [600] “Extension Group Assignment”.
- External:** Makes a voice announcement over the external pager.
- All Extensions & External:** Makes a voice announcement to all extensions over the built-in speakers of proprietary telephones and the external pager.



- An extension user can also transfer a call after paging (Paging and Transfer). Also, pages can be denied (Paging Deny).
- An external pager (user-supplied) must be connected beforehand. One external pager can be connected to the system.
- A confirmation tone is sent to the extensions before the voice announcement or answering.
- A confirmation tone is sent to the external pager before the voice announcement. The tone to the external pager can be disabled in program [106].
- An extension which has set the Do Not Disturb (DND) or Paging Deny feature, or is in use cannot be paged.



- **Connection Reference**
2.9 External Pager (Paging Equipment) Connection
- **Required System Programming**
[\[106\] External Paging Access Tone](#)
- **Related Feature References**
Extension Group, Do Not Disturb (DND)
- **Operating Instructions Reference**
1.5 During a Conversation, “Paging”

Paralleled Telephone Connection

Any analogue proprietary telephone can be connected in parallel with a single line device, such as a single line telephone, facsimile and data terminal.



- System Programming is required.



- **Connection Reference**
2.11 Paralleled Telephone Connection
- **Required System Programming**
[\[610\] Paralleled Telephone Connection](#)
- **Related Feature Reference**
Power Failure Transfer
- **Operating Instructions Reference**
1.7 Useful Features, “Parallel Connection of a Proprietary Telephone and Single Line Telephone (Paralleled Telephone Connection)”

Personal Speed Dialling

Allows an extension user to store up to 10 speed dialling numbers (0 through 9) with a maximum of 24 digits per number. An extension number, telephone number or feature number can be stored. For example, storing extension numbers for each room in a house can be useful. (1 = Living Room, 2 = Kitchen, etc.) To make a call, dial # and the number.



- Proprietary telephone users cannot use this feature if One-Touch Dialling buttons are assigned to PF buttons. If the user assign a personal speed dialling number, the number stored in the One-Touch Dialling button will be overwritten and vice versa. PF Buttons F1 through F10 correspond to the speed dialling numbers as follows.

| | |
|--------|---------|
| F1 — 0 | F6 — 5 |
| F2 — 1 | F7 — 6 |
| F3 — 2 | F8 — 7 |
| F4 — 3 | F9 — 8 |
| F5 — 4 | F10 — 9 |

- A rotary telephone user cannot use this feature.



- **Operating Instructions References**
1.3 Making Call, “Dialling with Personal Speed Dialling (Personal Speed Dialling)”

Pickup Dialling

Allows a single line telephone user to make an outgoing call by going off-hook, if the user has stored the telephone number (up to 32 digits) beforehand. This feature is also known as Hot Line.



- A rotary telephone cannot program this feature.
- The user can set and cancel this feature.
- If the feature is activated and the user goes off-hook, a dial tone will be generated for the delay time assigned in program [203] and then dialling will start. During the delay time, the user can dial another party overriding the Pickup Dialling function.



- **Required System Programming**
[\[203\] Pickup Dial Delay Time](#)
- **Operating Instructions Reference**
1.3 Making Call, “Dialling by Simply Going Off-Hook (Pickup Dialling)”

Polarity Reverse Detection

The circuit in the system can detect an exchange line polarity reverse signal from the Local Exchange when trying to make an outside call. This detects the start (a called party goes off-hook) and end (the called party goes on-hook) of an outgoing outside call. The conversation time can be verified on the SMDR printout using this feature.

When an outside call is received, the circuit can also detect the polarity reverse signal before ringing.



- **Required System Programming**
[\[424\] Reverse \(Polarity\) Circuit Assignment](#)
- **Related Feature Reference**
Station Message Detail Recording (SMDR)

Power Failure Transfer

During a power failure, specific extension telephones are automatically connected to specific exchange lines. This provides exchange line conversations between the following extensions and exchange lines.

Exchange line 1 : extension port 01

Exchange line 4 : extension port 09

A single line telephone (SLT) can work in case of a power failure. Connect an SLT to the above extension port. For more information, refer to the Operating Instructions.



- All other conversations, except the above combinations, are disconnected during a power failure.
- Only an exchange line can have a conversation. All other features do not work.
- We recommend connecting a single line telephone (SLT) in parallel at extension ports 01 and 09, so that an SLT can be used during a power failure.



- **Connection Reference**
2.18 Auxiliary Connection for Power Failure Transfer
- **Related Feature Reference**
Paralleled Telephone Connection
- **Operating Instructions Reference**
1.7 Useful Features, “Power Failure Transfer”

Preferred Line Assignment — Incoming

A proprietary telephone user can select the method to answer incoming outside calls from the following 3 line preferences. System Programming and Proprietary Telephone Settings are required.

- No Line Preference:** When an incoming call is received, the extension user must go off-hook and then press the flashing line key.
- Prime Line Preference:** When incoming calls are received at the same time, the user can receive the call on the preferred exchange line by only going off-hook.
- Ringing Line Preference:** When an incoming call is received, the user can receive the call ringing at their telephone by going off-hook.



- A single line telephone can only set “Ringing Line Preference”.
- Line access key(s) (Single Exchange Line, Other Exchange Line or Trunk Group) should be assigned to line key(s) beforehand.



- **Required System Programming**
[\[408\]–\[410\] Flexible Ringing Assignment — Day/Night/Lunch](#)
[\[411\]–\[413\] Delayed Ringing Assignment — Day/Night/Lunch](#)
- **Related Feature Reference**
Line Access Keys
- **Operating Instructions References**
 1.2 Proprietary Telephone Settings, “Customising Your Telephone Functions”, Preferred Line Assignment — Incoming
 1.2 Proprietary Telephone Settings, “Customising the Buttons on Your Telephone”, Line Access Keys

Preferred Line Assignment — Outgoing

A proprietary telephone user can select a desired outgoing line preference to make outside calls from the following 3 line preferences. System Programming and Proprietary Telephone Settings are required.

- Idle Line Preference:** When the user goes off-hook, they are connected to an idle line. An idle line is automatically selected from the pre-assigned lines in program [419].
- Prime Line Preference:** When the user goes off-hook, they are connected to the pre-assigned line. Assign one prime line beforehand.
- No Line Preference:** No line is selected when the user goes off-hook. They must select a line to make a call.



- Line Access Key(s) (Single Exchange Line, Other Exchange Line or Trunk Group) should be assigned to the line key(s) beforehand.



- **Required System Programming**

- [\[400\] Exchange Line Connection Assignment](#)

- [\[405\]–\[407\] Flexible Outward Dialling Assignment — Day/Night/Lunch](#)

- [\[419\] Automatic Designated Exchange Line Access](#)

- **Related Feature Reference**

- Line Access Keys

- **Operating Instructions References**

- 1.2 Proprietary Telephone Settings, “Customising Your Telephone Functions”, Preferred Line Assignment — Outgoing

- 1.2 Proprietary Telephone Settings, “Customising the Buttons on Your Telephone”, Line Access Keys

Proprietary Telephone Setting Data Default Set

Allows a proprietary telephone user to reset the following Proprietary Telephone Settings to the default settings.

- Preferred Line Assignment — Outgoing
- Preferred Line Assignment — Incoming
- Exchange Line Ringing Selection
- Intercom Alert Assignment
- Call Waiting Tone Selection



- **Operating Instructions Reference**

- 1.2 Proprietary Telephone Settings, “Customising Your Telephone Functions”, Proprietary Telephone Setting Data Default Set

Pulse to Tone Conversion

Allows an extension user to change the dialling mode from Pulse to Tone after entering a telephone number to access services, such as computer telephone services or Voice Mail, which require tones.



- This feature only works for exchange lines which have set “Pulse Mode” or “Call Blocking Mode” in program [401].
- Changing from Tone to Pulse is not possible.



- **Required System Programming**
[\[401\] Dial Mode](#)
- **Operating Instructions Reference**
1.7 Useful Features, “Pulse to Tone Conversion”

Recall

The RECALL button is used to allow a proprietary telephone user to disconnect the current call and originate another call without hanging up. This is activated when “MODE2” is selected in program [110] and the RECALL button is pressed for longer than the time programmed in [418]. When “MODE1” is selected in program [110], the RECALL button can be used to access features of the Local Exchange or host PBX (External Feature Access). It is performed by putting the current party on hold and sending a recall signal while having an outside call.



- Assigning the External Feature Access feature to any flexible button is useful when “MODE 2” was selected in program [110]. This can be done from any extension by assigning the RECALL button to a One-Touch Dialling button (☞ Operating Instructions, 1.2 Proprietary Telephone Settings, “Customising the Buttons on Your Telephone”, One-Touch Access for System Features). When the assigned button is pressed, a recall signal is sent during the programmed time in [418].



- **Required System Program Address**
[\[110\] Recall Key Mode](#)
[\[418\] Recall Time](#)
- **Operating Instructions Reference**
1.7 Useful Features, “External Feature Access”

Recall Button on a Single Line Telephone

Pressing the Recall button is used to allow a single line telephone user to hold a call for transferring or holding, if the recall time is within the assigned time in program [207]. The procedure to transfer a call or hold is determined in program [104] “Hold Mode Selection”. Pressing the Recall button can be also used to disconnect a call, if the recall time is more than the assigned time in program [207].



- If “MODE 1” was selected in program [207], the system will recognise pressing the Recall button as hooking, while a busy tone or reorder tone is sent or during a conversation. The system will recognise as 1 being dialled in the pulse mode, while a dial tone is sent. The system can refuse receiving a pulse signal by selecting “Disable” in program [614]. Therefore, even if the Recall button is pressed during a dial tone, the system will regard it as hooking.



- **Required System Programming**
 - [\[207\] Recall Timing Range Selection](#)
 - [\[614\] Internal Pulse Detection](#)

Receiving Calls

Allows an extension user to receive an intercom or outside call by going off-hook. A proprietary telephone user can also receive a call by pressing the rapid flashing CO or INTERCOM button, and talk (handsfree mode) if the telephone has the SP-PHONE button.



- A proprietary telephone user can select the Line Preference for incoming outside calls. See “Preferred Line Assignment — Incoming” in this section.



- **Required System Programming**
 - [\[408\]–\[410\] “Flexible Ringing Assignment — Day/Night/Lunch”](#)
 - [\[411\]–\[413\] “Delayed Ringing Assignment — Day/Night/Lunch”](#)
- **Related Feature Reference**
 - Preferred Line Assignment — Incoming
- **Operating Instructions Reference**
 - 1.4 Receiving Calls, “Receiving Calls”

Redial

<Last Number Redial>

Every extension automatically saves the last telephone number dialled so that the extension user can make a call to the same party later using a simple operation.

<Saved Number Redial>

Allows a proprietary telephone user to save the current external telephone number in the SAVE button during a conversation, so that the extension user can redial the same party later using a simple operation. The saved number can be redialled until another number is stored. A flexible button can be assigned as the SAVE button in the Proprietary Telephone Settings.



• Operating Instructions References

- 1.2 Proprietary Telephone Settings, “Customising the Buttons on Your Telephone”, SAVE button
- 1.3 Making Calls, “Redialling the Last Number Dialled (Last Number Redial)”
- 1.3 Making Calls, “Redialling the Saved Number (Saved Number Redial)”

Ringling Pattern Selection

A ringing pattern can be selected depending on the type of call such as an outside call, intercom call and doorphone call. Available ringing patterns are as follows:

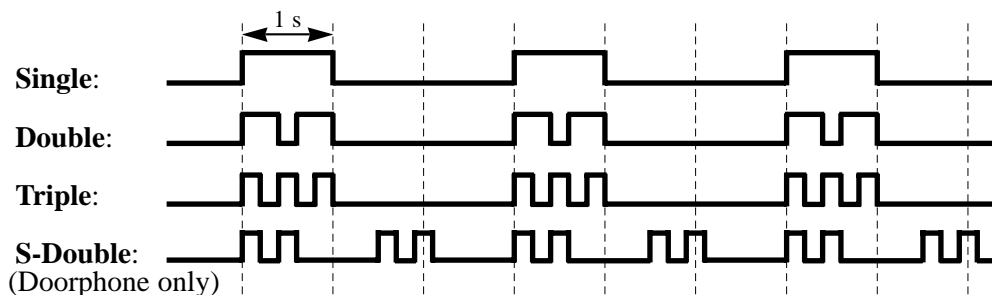

- Private calls can be distinguished from business calls by assigning different ringing per exchange line. Moreover, by assigning different ringing, intercom calls and doorphone calls can be distinguished from other calls. Therefore, careful attention should be applied to all ringing assignments.



• Required System Programming

- [\[115\] Extension Ringing Pattern Selection](#)
- [\[423\] Exchange Line Ringing Pattern Selection](#)
- [\[706\] Doorphone Ringing/Tone Pattern Selection](#)

• Related Feature Reference

- Exchange Line Ringing Selection

Room Monitor

Allows a proprietary telephone or single line telephone with a MUTE button to monitor a room or the front door through another proprietary telephone or doorphone without them knowing. The access tone will not be sent to the monitored proprietary telephone when monitoring starts.



- The extensions that can be monitored must be programmed in [612] before operation is possible.
- If a doorphone is used as a room monitor, the access tone will be heard when monitoring starts as the default setting. The tone can be disabled in program [707].
- This feature is not available for KX-T7050.
- A single line telephone with a MUTE button can be used for monitoring, but cannot be monitored.



- **Required System Programming**
 - [\[612\] Room Monitor Assignment](#)
 - [\[707\] Doorphone Access Tone Selection](#)
- **Related Feature Reference**
 - Doorphone Call
- **Operating Instructions Reference**
 - 1.7 Useful Features, “Room Monitor”

Secret Dialling

Allows a proprietary telephone user to conceal all or part(s) of a System Speed Dialling number assigned in program [001] or One-Touch Dialling number assigned to a flexible button in the Proprietary Telephone Settings which would normally appear on the display.



- When storing a number, press the INTERCOM button at the beginning and the end of the numbers to be concealed.
- One or more parts of a telephone number can be concealed.
- Printing out the concealed number on a SMDR can be assigned in program [803].



- **Required System Programming**

- [\[001\] System Speed Dialling Entry](#)

- [\[803\] Secret Speed Dialling/One-Touch Dialling Printing](#)

- **Related Feature References**

- One-Touch Dialling, System Speed Dialling

- **Operating Instructions References**

- 1.2 Proprietary Telephone Settings, “Customising the Buttons on Your Telephone”, One-Touch Dialling Button

- 1.7 Useful Features, “Secret Dialling”

Self-Extension Number Confirmation (KX-T7130 only)

Allows a display proprietary telephone user to confirm their port and extension number using a simple operation.



- **Operating Instructions Reference**

- 1.7 Useful Features, “Self-Extension Number Confirmation (KX-T7130 only)”

Station Message Detail Recording (SMDR)

Station Message Detail Recording (SMDR) automatically prints out detailed call information of outside calls. A printer connected to the Serial Interface (RS-232C) port can be used to print incoming and outgoing outside calls, as well as print a hard copy of System Programming. To print out the record of System Programming items that have been assigned, use program [804] “System Data Dump”. To print the call records, use program [802] “Incoming/ Outgoing Call Selection for Printing”, which prints out the following records.

- A record of all outgoing outside calls or outgoing toll calls
- A record of all incoming outside calls

An example of a printed call record:

| Date | Time | Ext. | CO | Dial number | Duration | Code |
|----------|----------|------|----|----------------------------------|----------|------|
| 31/12/98 | 12:52PM | 203 | 05 | 12345678901234567890123456789012 | 00:00'16 | |
| 31/12/98 | 12:53PM | 203 | 02 | < incoming > | 00:01'43 | |
| 31/12/98 | *12:54PM | 201 | 02 | < incoming > | 00:07'48 | |
| 31/12/98 | 1:04PM | 203 | 06 | 092...1438 | 00:00'06 | 4536 |
| 31/12/98 | 1:04PM | 202 | 05 | < DISA incoming > | 00:00'09 | |
| 31/12/98 | 1:05PM | 203 | 01 | < DISA incoming > | 00:00'08 | |
| 31/12/98 | 1:06PM | 203 | 01 | 092123456789 | 00:00'08 | |
| 31/12/98 | 1:06PM | 202 | 02 | 0921234567 | 00:00'17 | |
| 31/12/98 | 1:07PM | 203 | 01 | 0921234567 | 00:11'00 | ..13 |
| 31/12/98 | 2:15PM | 203 | 01 | 0921234567 | 00:11'00 | .201 |
| 31/12/98 | 2:26PM | 203 | 01 | F/0927654321 | 00:03'00 | |
| 31/12/98 | 2:27PM | 216 | 05 | 9=0924567123 | 00:13'55 | |
| 31/12/98 | 3:25PM | | 02 | < UCD Waiting > | 00:11'48 | |

Example of the SMDR printout format:

Explanation

- (1) Date : shows the date of the call as Day/Month/Year.
- (2) Time : shows the time the call was started as Hour: Minute/AM or PM.
“*” indicates a transferred call.
- (3) Ext. : shows the extension number, etc. that engaged in the call.
- (4) CO : shows the exchange line number used for the call.
- (5) Dial number

Outgoing call: Shows the called party’s telephone number (maximum 32 digits). Valid digits are 0 through 9, #, * and P (if the PAUSE button was pressed).

Received call: Shows <incoming>. An incoming call via the DISA feature is shown as <DISA incoming>, via the DIL feature is shown as <DIL incoming>.

UCD waiting call: Shows <UCD waiting> for an incoming call via the UCD feature. When the “UCD waiting call” is answered, it becomes a “Received call” and a new record is started.

- (6) Duration : shows the duration of the call or the UCD call waiting time in Hours/Minutes/Seconds.
- (7) Code: shows the account code appended to the call, account code index number (e.g.: 13) or the extension number which uses the Walking COS feature (e.g.: 201).



- This system can store information of up to 64 calls.
- This data is not deleted even when the system is reset.
- If RECALL is manually sent out during a conversation to make another call without hanging up, etc., a call record will be printed and a new record started. “F/” will be printed at the beginning of the dial number on the new record.
- When a host PBX code is entered, “=” will be printed between the code and dialled number.
- The language used for an SMDR printout can be selected in program [806].



- **Connection Reference**
2.13 Printer and PC Connection
- **Required System Programming**
 - [000] Date and Time Setting
 - [204] Call Duration Count Start Time
 - [800] SMDR RS-232C Communication Parameters
 - [801] SMDR Parameter
 - [802] Incoming/Outgoing Call Selection for Printing
 - [803] Secret Speed Dialling/One-Touch Dialling Printing
 - [804] System Data Dump
 - [805] SMDR Account Code Selection
 - [806] SMDR Language Assignment
- **Related Feature Reference**
Language Selection

System Data Default Set

This system can re-initialise the system-programmed data. If all the programmed data is cleared, the system will reset using the default settings by program [999].



- The default setting for each programming item is listed in Section 5.1, Default Values.



- **Required System Programming**
[999] System Data Clear
- **Installation Reference**
2.23 System Data Clear

System Speed Dialling

The system supports 100 System Speed Dial numbers (up to 32 digits) assigned in program [001] that are available to all extension users. A System Speed Dial number is dialled out using a simple operation.

Each System Speed Dial number can be assigned a name in program [011]. The assigned name will be displayed when making a call by using the System Speed Dialling feature. It will also be displayed when an external caller's telephone number matches one of System Speed Dialling numbers and the Telephone Company does not provide the caller's name.



- Call Barring for System Speed Dialling can be assigned by program [301].
- A rotary telephone user cannot use this feature.



- **Required System Programming**
 - [\[001\] System Speed Dialling Entry](#)
 - [\[011\] System Speed Dialling Name Setting](#)
 - [\[301\] Call Barring – System Speed Dialling Boundary Class](#)
- **Related Feature**
 - Call Barring for System Speed Dialling
- **Operating Instructions for the Caller ID Card References**
 - Section 1.2, System Features
 - Caller ID
- **Operating Instructions Reference**
 - 1.3 Making Calls, “Dialling with System Speed Dialling (System Speed Dialling)”

Timed Reminder

<Timed Reminder>

Allows an extension user to generate an alarm tone at a preset time as a wake-up alarm or a reminder. The user can set this to be activated once or everyday.

<Timed Reminder, Remote (Wake-Up Call)>

The operator or manager can remotely set, cancel and confirm the Timed Reminder of the desired extension. For example, this is useful for a small hotel or motel to set an extension in a guest room as a wake-up call, or set an extension in a child's room by a mother.



- **Operating Instructions References**
 - 1.7 Useful Features, “Alarm Setting (Timed Reminder)”
 - 1.8 Operator / Manager Service Features, “Timed Reminder, Remote (Wake-Up Call)”

Time (Day/Night/Lunch) Service

The system supports the day, night and lunch operation modes. The system operation for making and receiving calls can be different for the day, night and lunch modes. The system operation for call barring can be arranged to prevent unauthorised toll calls for each mode. Time service can be set automatically or manually by program [006].

Changing the Day/Night/Lunch Modes

The day, night and lunch modes can be changed either automatically at an assigned time in program [007] or manually by the operator or manager at any desired time.



- The lunch mode interrupts the day or night mode. After the lunch mode is finished, the day or night mode starts again.
- If the lunch mode is set using feature number “783#” in the automatic mode, the mode can only be cancelled by using feature number “780#”. This can be useful during holidays. The day and night modes are automatically changed at the programmed time in [007] even if feature number “780#” is not entered. These operations can only be done by an operator or manager.
- The operator and manager can see the status of the mode (day, night or lunch) by the pre-assigned DSS buttons’ LED on the DSS console. Time service can be changed easily by pressing the pre-assigned DSS buttons.
- The following programming items will be affected by the time service.

- [405]-[407] Flexible Outward Dialling Assignment
 - Day/Night/Lunch
- [408]-[410] Flexible Ringing Assignment
 - Day/Night/Lunch
- [411]-[413] Delayed Ringing Assignment
 - Day/Night/Lunch
- [414]-[416] Exchange Line Mode — Day/Night/Lunch
- [601]-[603] Call Barring – Class of Service Assignment
 - Day/Night/Lunch
- [700]-[702] Doorphone Ringing Assignment
 - Day/Night/Lunch
- [703]-[705] Door Opener Assignment
 - Day/Night/Lunch

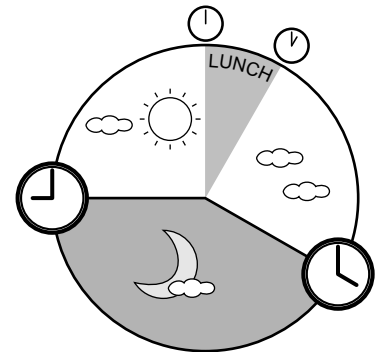

- **Required System Programming**

- [\[006\] Time \(Day/Night/Lunch\) Service Changing Mode](#)
- [\[007\] Time \(Day/Night/Lunch\) Service Start Time](#)

- **Operating Instructions References**

- 1.8 Operator / Manager Service Features, “Time (Day/Night/Lunch) Service Setting”
- 1.9 DSS Console Features, “Initial Settings”, Day, Night and Lunch Buttons Assignment

Uniform Call Distribution (UCD)

Distributes incoming calls to one specific extension group called a UCD group assigned in program [520]. Calls to the UCD group hunt for an idle extension in numerical order. The UCD feature is particularly helpful when a certain extension receives a high volume of calls compared with other extensions.



- An optional OGM/FAX Detection Card is required to perform the UCD feature.
- The Log-In or Log-Out status can be set on an extension basis. There should be at least one extension that is in Log -In status in the UCD group.
- An extension which sets the Call Forwarding–All, –Busy or No Answer, or the Do Not Disturb (DND) feature is skipped during circular calling.
- When all extensions in the UCD group are busy, a busy message is heard and then Music on Hold is activated. If any extension in the UCD group is not available within the programmed time period, then (1) an OGM will be heard and the call is disconnected, or (2) the call will be sent to pre-programmed extension(s) in [408]-[410]. System Programming is required for this operation. Refer to the “Flow chart of possible cases and results for UCD calls”.



- **Connection Reference**
 - 2.15 OGM/FAX Detection Card Installation
- **Required System Programming**
 - [111] Hold Music Selection
 - [408]-[410] Flexible Ringing Assignment – Day/Night/Lunch
 - [414]-[416] Exchange Line Mode — Day/Night/Lunch
 - [502] OGM Mode Selection
 - [513] Cyclic Tone Detection
 - [520] UCD Group
 - [521] UCD Busy Waiting Time
 - [522] UCD OGM Message Interval Time
 - [523] UCD Busy Mode
 - [524] UCD Intercept Mode
 - [525] UCD Ringing Time before Intercept
 - [526] UCD Ringing Time after Intercept
 - [600] Extension Group Assignment
- **Related Feature References**
 - Call Forwarding, Do Not Disturb (DND), Extension Group, Log-In/Log-Out

Outline of a UCD

- (1) When a number of calls have arrived at the UCD group, the first call arrives at extension A first.
- (2) When the first call arrives at extension A, the second call arrives at extension B.

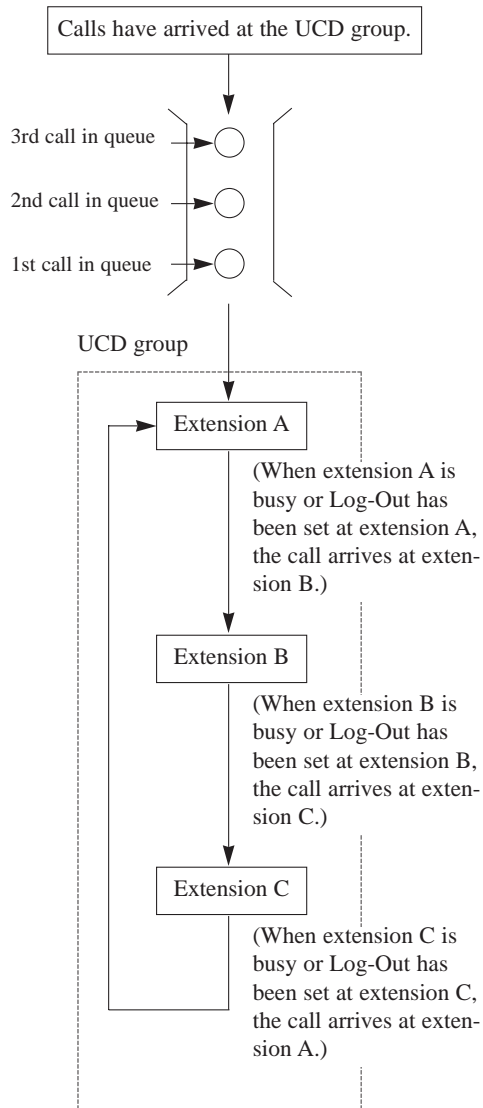

- (2) When the first call arrives at extension A, the second call arrives at extension B.

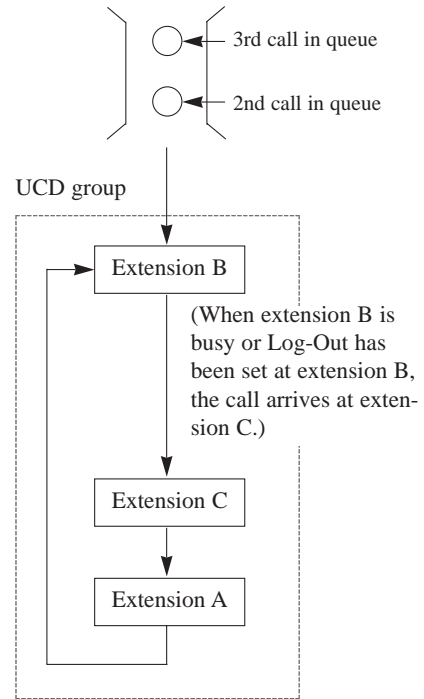

- (3) When the second call arrives at extension B, the third call will arrive at extension C.

Flow chart of possible cases and results for UCD calls

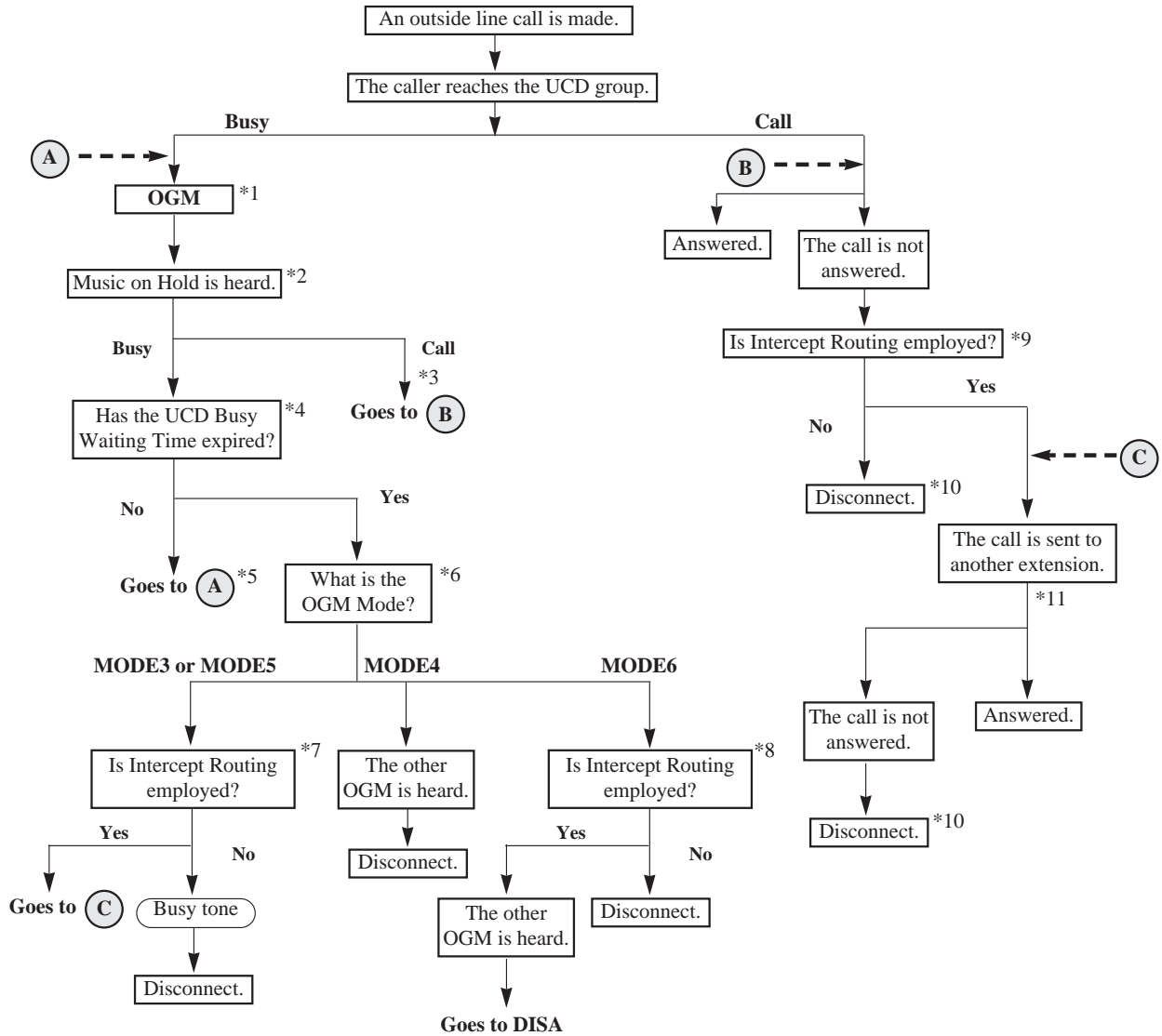

Note: The explanation for *1 through *11 is on the next page.

- *1: An OGM is sent to the caller.
When the system detects a cyclic tone or CPC signal while the OGM is being sent, the call is disconnected.
- *2: Music on hold is selected in program [111] as follows.
 - **External** – Uses an external music source, such as a radio.
 - **Tone** – Uses the cyclic tone equipped with the system.
- *3: When an extension in the UCD group is available.
- *4: The system holds the call until the assigned time in program [521] expires.
- *5: OGM repeats the assigned time intervals in program [522] within the assigned time in program [521].
- *6: The OGM Mode is selected in program [502].
- *7: The system treats the call according to program [523] as follows when the assigned time in [521] expires.
 - **Disconnect** – The call is disconnected.
 - **Intercept** – The call is sent to the extensions programmed in [408]-[410].
- *8: The system treats the call according to program [523] as follows when the assigned time in [521] expires.
 - **Disconnect** – The call is disconnected.
 - **Intercept** – The other OGM leads the caller to the DISA feature (☞ “Direct Inward System Access (DISA)” in this section).
- *9: The system treats the call according to program [524] as follows when the assigned time in [525] expires.
 - **Disconnect** – The call is disconnected.
 - **Intercept** – The call is sent to the extensions programmed in [408]-[410].
- *10: If the caller did not hear an OGM, the call will not be disconnected until the caller goes on-hook.
- *11: The UCD Ring Timer after Intercept starts. The destination telephone(s) will ring for the time programmed in program [526]. If the call is not answered during the programmed time, the call will be disconnected.

Voice Mail Integration for KX-TVP100

This system supports Panasonic Voice Processing System (VPS) equipment (KX-TVP100) by sending DTMF tones described in program [103]. The DTMF tones sent to a VPS indicate the state of a call (busy, answered, ringing, disconnected, etc.). The DTMF tones also inform a VPS of the destination of a call transferred to the VPS by the Call Forwarding or DISA Intercept Routing – No Answer feature. Up to 4 VPSs can be connected to the extension ports as extensions in the system.

System Explanation

1. Voice Mail Service

1.1 Call Forwarding to VM

If an extension user sets Call Forwarding (C. FWD) whose destination is the VPS, an incoming call is forwarded to the VPS. The system sends the VPS the extension mailbox number at that time. Therefore, the calling party can leave their message in the mailbox of the desired extension without having to know the mailbox number.

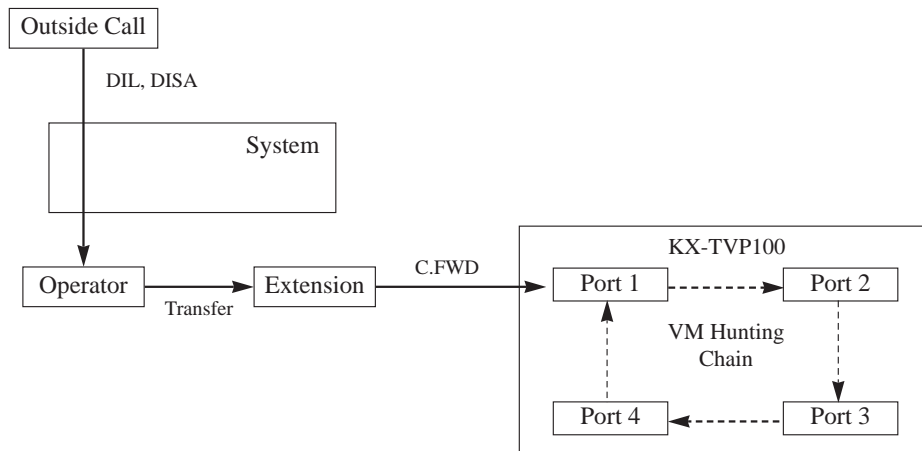
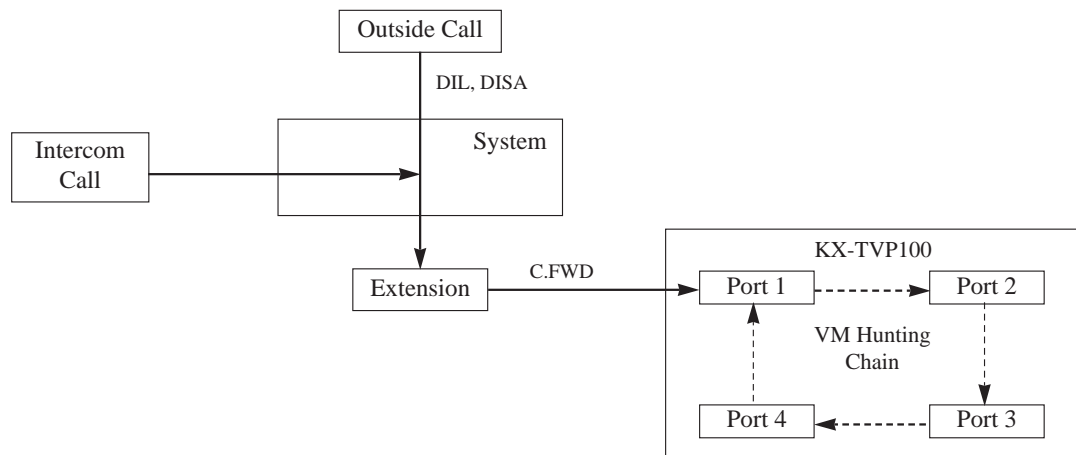

1.2 DISA Intercept to VM

If the VPS is set as the Intercept destination of an exchange line, an outside call is forwarded to the VPS. The system sends the VPS the extension mailbox number at that time. Therefore, the calling party can leave their message in the mailbox of the desired extension without having to know the mailbox number. If a DISA call is transferred to the VPS by Intercept Routing from a DISA ring group, your system will transmit the mailbox number of the lowest port number of the DISA ring group. Delayed Ringing must be assigned to VPS extensions in programs [411]-[413].

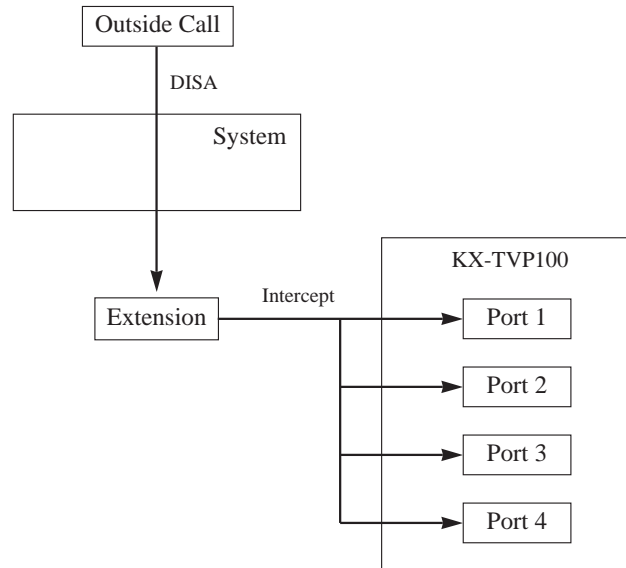

1.3 Listening to a Recorded Message

If the VPS receives a message, the VPS can turn on the MESSAGE button indicator on the corresponding proprietary telephone to notify the user. The VPS notifies the extension user that there is a message waiting in their mailbox. When the MESSAGE button indicator is lit, pressing the button allows the extension user to play back the stored message. A single line telephone user hears dial tone 3 (☞ “Distinctive Dial Tones” in this section) when going off-hook if there are messages in their mailbox. They can call the voice mail extension to listen to their messages. In this case, they must listen to all of the messages. Once they access voice mail, dial tone 3 will be eliminated and not be heard next time they go off-hook. Therefore, they will not know even if there are messages left.

2. Automated Attendant (AA) Service

2.1 AA to Extension

AA receives and answers outside calls and offers services such as transferring to an extension or mailbox using DTMF signalling, which is sent from the calling party.

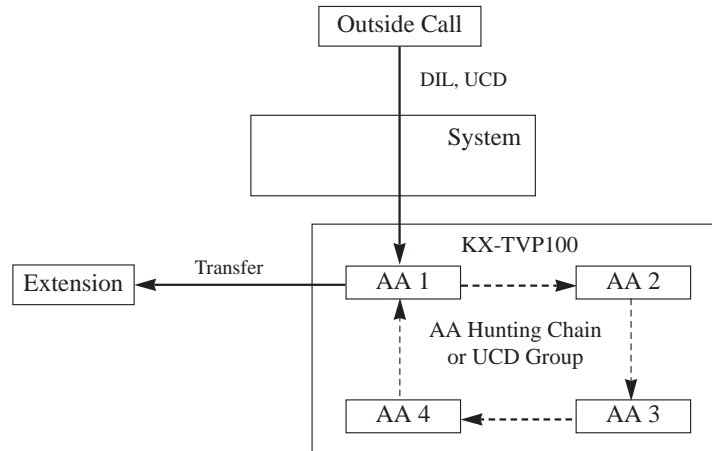

- A VPS can be assigned as the destination for the following features.

Call Forwarding – All Calls

Call Forwarding – Busy/No Answer

DISA Intercept Routing – No Answer

In these functions, the caller does not need to know the mailbox number of the called extension because the code is automatically transmitted to the VPS.

- The mailbox number is the same as its extension number.
- The Voice Mail extension should set Data Line Security to prevent interference from system signals.
- If KX-TA624 cannot be selected with the PBX type setup menu of the KX-TVP100, select “KX-T1232”. Follow the steps for a KX-T1232.



- **Connection Reference**

2.8 Extension Connection

- **Required System Programming**

[009] Extension Number Assignment

[102] Voice Mail Port for KX-TVP100

[103] DTMF Integration for KX-TVP100

[408]-[410] Flexible Ringing Assignment — Day/Night/Lunch

[411]-[413] Delayed Ringing Assignment — Day/Night/Lunch

[414]-[416] Exchange Line Mode — Day/Night/Lunch

[507] DISA Intercept Mode

- **Related Feature References**

Call Forwarding, Data Line Security, Direct Inward System Access (DISA), Distinctive Dial Tones, Extension Hunting, Intercept Routing

- **Operating Instructions Reference**

1.7 Useful Features, “Voice Mail Integration for KX-TVP100”

Volume Control

Allows a proprietary telephone user to adjust the following volumes, as necessary, by adjusting the corresponding levers or pressing the corresponding buttons.

- Handset receiver volume
- Ringer volume
- Speaker volume



- **Operating Instructions Reference**

- 1.2 Proprietary Telephone Settings, “Volume Control — Handset Receiver/Ringer/Speaker”

Walking COS

Allows an extension user who is not at their own telephone to override the call barring COS number of another extension by dialling their extension password. For the duration of the call, the COS of the extension is changed to the COS of their own extension.



- If the extension overriding call barring is assigned to “Forced” or “Verify–All”, the user must enter the account code before the line access code.
- When a user makes a call using this feature, the user’s extension number will be displayed on the SMDR, not the extension where the user made the call.



- **Operating Instructions References**

- 1.7 Useful Features, “Calling Using Your Privileges at Another Extension (Walking COS)”

- 1.8 Operator / Manager Service Features, “Extension Password Set (Manager only)”