

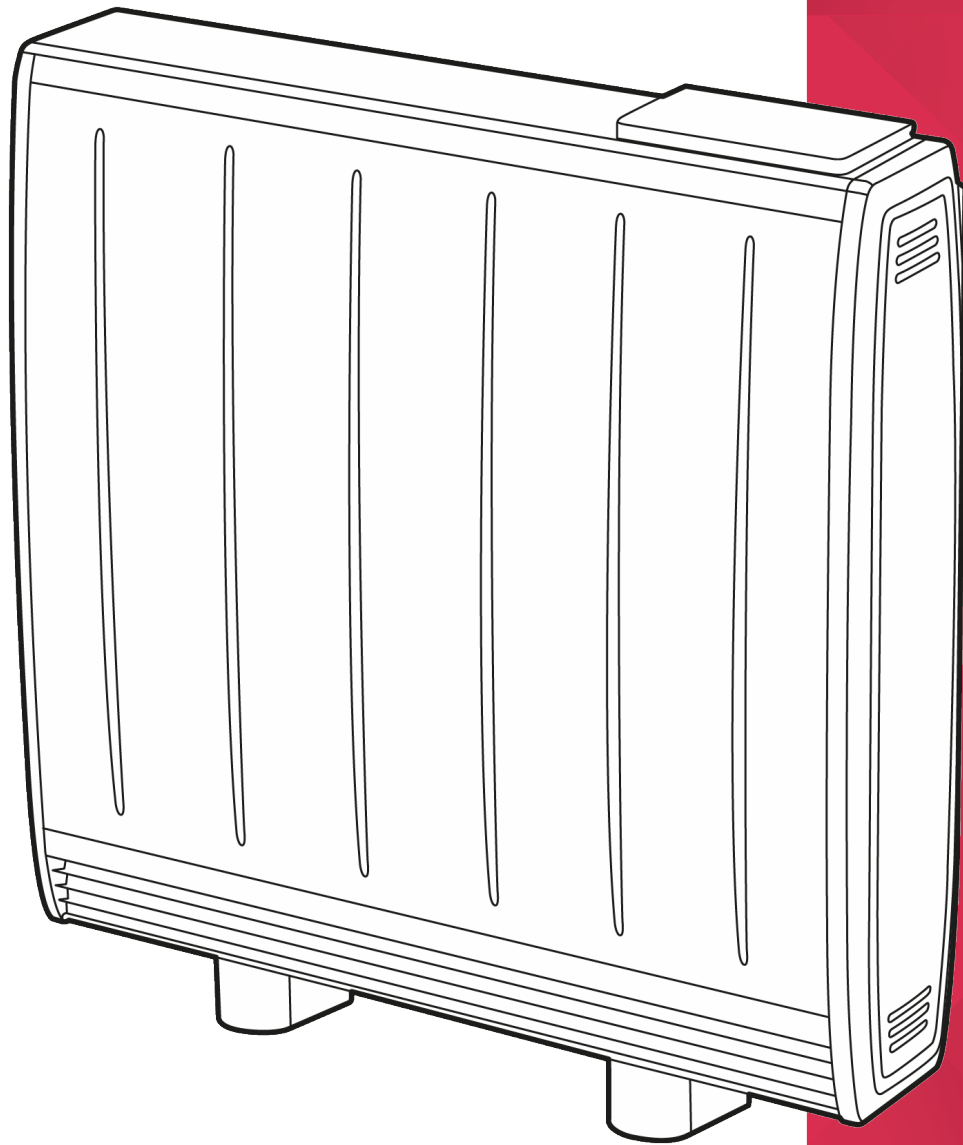

## INSTALLATION MANUAL



### **Quantum Series Heater**

Models: QM050RF / QM070RF / QM100RF  
QM125RF / QM150RF



## IMPORTANT

THESE INSTRUCTIONS SHOULD BE READ CAREFULLY AND RETAINED FOR FUTURE REFERENCE. **Note also the information presented on the appliance**



Warnings in this document are identified by a warning triangle against a grey background.

Keywords at the start of a warning indicate the type and seriousness of the ensuing risk if measures to prevent the risk are not taken.

The following keywords are defined and can be used in this document:

- **DANGER** indicates a hazardous situation which, if not avoided, will result in death or serious injury.
- **WARNING** indicates a hazardous situation which, if not avoided, could result in death or serious injury.
- **CAUTION** indicates a hazardous situation which, if not avoided, could result in minor to moderate injury.
- **NOTICE** is used to address practices not related to personal injury.

## CAUTION

**FAILURE TO FOLLOW THESE INSTRUCTIONS MAY CAUSE INJURY AND/OR DAMAGE AND MAY INVALIDATE YOUR GUARANTEE**

## IMPORTANT SAFETY ADVICE

When using electrical heaters, basic precautions should always be followed to reduce the risk of fire, electrical shock, and injury to persons, including the following:

**IMPORTANT** - The wall bracket supplied with the heater must be used.

**IMPORTANT** - All packaging should be disposed of in an appropriate manner.

## OVERHEATING WARNING

**WARNING** - In order to avoid overheating, do not cover or obstruct the heater. Do not place material or garments on the heater, or obstruct the air circulation around the heater, for instance by curtains or furniture, as this could cause overheating and a fire risk. NEVER cover or obstruct in any way the heat outlet slots at the top of the heater or the air outlet slots in the base of the heater.

## WARNING - THE SURFACES ON THIS HEATER CAN BE HOT.



The heater carries a warning 'DO NOT COVER' to alert the user to the risk of fire that exists if the heater is accidentally covered.

**CAUTION** - Some parts of this product can become very hot and cause burns. Particular attention has to be given where children and vulnerable people are present.

For your safety this heater is fitted with a thermal cut-out. In the event that the product overheats for some reason, the cut-out prevents excessive temperatures on the product by cutting the power to the heater. Once the heater has cooled down, it will reset automatically, it will continue to cycle on and off automatically until the reason for overheating is removed.

The display screen may flash red to indicate the product has overheated. To reset the display, remove the obstruction and hold **Enter** for 10 seconds.

## SUITABLE APPLICATIONS

**WARNING** - This heater is suitable for normal dwelling purposes and should not be used in any other type of environment. This product should only be used in the country where it was purchased from by a recognised commercial retailer. **Do not use outdoors.**

## SERVICING AND REPAIRS

**WARNING** - Servicing and product repairs should only be undertaken by the manufacturers approved service agent or a similarly trained or qualified person, using only exact manufacturer approved spare parts.

**PLEASE NOTE:** Household dust, lit cigarettes, candles and oil burners, combined with the convection effect of electric heaters can cause significant soot deposits to build up on the surface directly above and to the sides of the heater. This is not a fault of the heater. Extensive burning of candles or smoking in the operating environment of this product can produce heavy discolouration within a few months of use.

## OPERATING WARNINGS

**IMPORTANT:** Remember to observe all safety warnings and precautions when operating the heater on the automatic or timer modes, either attended or unattended since a fire risk exists when the heater is accidentally covered, obstructed or displaced.

**CAUTION:** Do not use if either of the heater's mains power leads become damaged. If the supply cord is damaged it must be replaced by the installer or an approved Dimplex service partner.

Do not sit or stand on the heater.

Ensure minimum clearances between the heater and other objects / surfaces are maintained.

## ELECTRICAL INSTALLATION

**WARNING - Minimum clearances and IP zone requirements must be adhered to in accordance with the current wiring regulations.**

Mains cables are not provided with this heater.

**WARNING** - The electrical installation of this heater must be carried out by a suitably qualified or trained electrician, and be in strict accordance with current wiring regulations.

The peak supply must be connected via a switched fused spur with a fuse rated suitably for the appliances flex, the off-peak supply, via a 20A double pole isolated switch. In both instances a plug and socket arrangement **MUST NOT** be utilised. The contact separation to be a minimum of 3mm.

Failure to follow these instructions will mean that the manufacturer's instructions have not been adhered to. **THERE ARE NO EXCEPTIONS.**

- This heater must be earthed
- Not suitable for connection via a plug top
- Do not locate the heater immediately above, below or in front of a fixed electrical point i.e. socket outlet.

This appliance is intended for installation to a single phase supply only and is not suitable for connection to 3 phase supplies.

## **ELECTRICAL INSTALLATION continued**

The heater is not fitted with a mains cable, this should be fitted by the installer. Cable type (minimum size) H05VV-F 1.5mm<sup>2</sup> three core for peak and 2.5mm<sup>2</sup> three core for off-peak for connection to the fixed wiring of the premises through suitable isolation devices positioned adjacent to the heater. The supply circuits to the heater must incorporate a double pole isolating switch having a contact separation of at least 3mm. In installation the supply cord must be cut to the appropriate length for the electrical connection point. Excess cable should not be inserted or stored behind the heater.

If, during reassembly of the heater, a part of the thermal insulation shows damage or deterioration, it should be replaced by an identical part.

**WARNING:** All electrical connections to the terminal block must be secure to prevent risk of ignition. Tighten to 2 Nm.

## **CHILD SAFETY**

**WARNING** - Fixing kit screws are a potential choking hazard.

**WARNING** - This appliance is not intended for use by persons (including children) with reduced physical, sensory or mental capabilities, or lack of experience and knowledge, unless they have been given supervision or instruction concerning use of appliance by a person responsible for their safety.

This appliance can be used by children from 8 years and above and persons with reduced physical, sensory or mental capabilities or lack of experience and knowledge if they have been given supervision or instruction concerning use of the appliance.

Children shall not play with the appliance.

Cleaning and user maintenance shall not be made by children without supervision.

Children of less than 3 years should be kept away unless continuously supervised.

Children aged from 3 years and less than 8 years shall only switch on/off the appliance provided that it has been placed or installed in its intended normal operating position and they have been given supervision or instruction concerning use of the appliance in a safe way and understand the hazards involved.

Children aged from 3 years and less than 8 years shall not regulate and clean the appliance or perform user maintenance.

**WARNING - KEEP BATTERIES OUT OF REACH OF CHILDREN**

**WARNING** - Packaging should be disposed of responsibly as the EPS used could be a potential choking hazard for children.



*This document is customer property and is to remain with this unit.*

*These instructions do not cover all the different variations of systems nor does it provide for every possible contingency to be met in connection with installation.*



### **WARNING: EARTHING**

This appliance must be earthed in accordance with the manufacturers recommendations and in accordance with IEE regulations for electrical equipment.

Failure to adequately earth the appliance can result in electrical shock causing severe personal injury or death.



### **WARNING: HAZARDOUS VOLTAGE**

Disconnect all power to unit before installing or servicing.

Hazardous voltage can cause severe personal injury or death.



### **WARNING: ACCESS TO LIVE PARTS**

If the supply cables to the appliance are damaged in anyway, they must be immediately replaced by a competent person in order to avoid electrocution which could cause severe personal injury or death.



### **WARNING**

The appliance must be securely fixed to the wall. The installed appliance could weigh up to 165kg and if it falls off the wall it could cause severe personal injury or death. It is the responsibility of the installer to ensure that the appropriate wall fixing is used and that the floor is capable of bearing the full weight.



## WARNING

To avoid a fire hazard the cardboard insert within the heater core must be removed before the heater is switched on. Also ensure all polystyrene packaging is removed before the heater is operated. Leaving combustible packaging in the appliance could lead to fire and cause severe personal injury, death and damage to property.



## CAUTION

The appliance is very heavy (up to 50kg) and care should be taken when handling during installation to reduce risk of muscular or skeletal injuries.



## CAUTION

The appliance should not be repeatedly switched on/off by an external room thermostat as this could lead to failures of the electronic controller and may invalidate the warranty – further clarification SHOULD BE SOUGHT FROM GDC HELPDESK.



## CAUTION

During the first 48 hours of operation rooms must be well ventilated as the heater will produce a smell. Young children, caged birds, or persons with respiratory complaints must not remain in close proximity to the appliance during the first 48 hours of operation.



*It is important that the appliance bricks are dry and free from mould growth. Wet or mouldy bricks can lead to an unpleasant odour and or steam being generated by the appliance which could upset the customer.*



## Energy Related Product Directive

This product meets the Ecodesign requirements for an electric storage local space heater. Commission Regulation (EU) 2015/1188.

Model Identifier(s):		QM050RF	QM070RF	QM100RF	QM125RF	QM150RF
<b>Heat Output</b>						
Nominal heat output	P <sub>nom</sub>	0.50kW	0.75kW	1.00kW	1.25kW	1.50kW
Minimum heat output (indicative)	P <sub>min</sub>	0.00	0.00	0.00	0.00	0.00
Maximum heat output	P <sub>max,c</sub>	0.90kW	1.20kW	1.50kW	1.70kW	2.00kW
<b>Auxiliary electricity consumption</b>						
At nominal heat output	el <sub>max</sub>	0.00	0.00	0.00	0.00	0.00
At minimum heat output	el <sub>min</sub>	0.00	0.00	0.00	0.00	0.00
In standby mode	e <sub>ISB</sub>	0.000	0.000	0.000	0.000	0.000
<b>Type of Heat input, for electronic storage local space heaters only</b>						
Electronic heat charge control with room temperature feedback				Yes		
Fan assisted heat output				Yes		
<b>Type of heat output / room temperature control</b>						
Electronic room temperature control plus week timer				Yes		

### Contact details

Glen Dimplex Heating and Ventilation

Millbrook House, Grange Drive, Hedge End, Southampton, SO30 2DF

Tel: 0344 879 3588

This product meets the Ecodesign requirements for an electric storage local space heater. Commission Regulation (EU) 2015/1188.

## Technical Details

Model Identifier(s):	QM050RF	QM070RF	QM100RF	QM125RF	QM150RF
Input rating +5% / -10%	936/1020W	1435/1560W	2042/2220W	2540/2760W	3024/3300W
Boost Output 230/240V-	312/340W	478/520W	681/740W	847/920W	1008/1100W
Rated Charge Period:	7.7 - 7 Hours	7.7 - 7 Hours	7.7 - 7 Hours	7.7 - 7 Hours	7.7 - 7 Hours
Max Storage Capacity	7.2kWh	10.9kWh	15.4kWh	19.3kWh	23.1kWh
Fan Wattage	11W	11W	11W	11W	11W
UI Wattage	0.5W	0.5W	0.5W	0.5W	0.5W
Sound Level dB (measured in test chamber)	27	29	32	30	31
Energy Cell Packs Required (047243)	4	6	8	10	12
Height (mm)	730	730	730	730	730
Width (mm)	580	703	865	1069	1069
Depth (mm)	185	185	185	185	185



All Models	
Controls	Digitally controlled, Electronic Thermostat accurate to ( $\pm 0.2^{\circ}\text{C}$ ).  <b>Timer modes:</b> 7 Day Programmable User Timer, Out All Day, Home All Day <b>Continuous heat modes:</b> Frost Protect <b>Additional Modes:</b> Away, Boost, Setback
Controller UI	<ul style="list-style-type: none"> <li>• Graphical display with RGB backlight</li> <li>• Tactile buttons with audio feedback</li> <li>• User replaceable battery (Coin-Type)</li> <li>• Open window detection, Adaptive Start, Advance Time Period</li> <li>• Wide SP range (<math>7\text{-}30^{\circ}\text{C}</math>)</li> <li>• Automatic Charge Control</li> <li>• History / Reporting Screens</li> <li>• Boost Mode, User Adjustable</li> <li>• Heat Demand % Adjustment</li> <li>• Child Lock &amp; Heater Lock (PIN-based)</li> </ul>
Safety	Electronic overheat protection. Additional electromechanical overheat protection. LVD and EMC compliance.
IP Rating	IPX4
Battery	3.3V coin cell battery to backup real time clock. Battery life > 5 years.
Supply	1/N/1/N/PE ~230-240V (Twin Supply) 230-240V / 50Hz Class I 1/N/PE ~230-240V (Single Supply) 230-240V / 50Hz Class I
Colour / Finish	Traffic White (RAL 9016), Grille RAL7035
Storage Core	High-density bonded magnetite energy cells
Approvals	CE & BEAB
Guarantee	2 Years. 10 Years extended available with registration.
Country of Origin	United Kingdom
Manufacturer	Glen Dimplex Heating & Ventilation (GDC Group Ltd)

## Preparation

### WARNING:

DO NOT PLACE OBJECTS WITHIN 300mm OF THE FRONT OF THE HEATER AND 150mm EITHER SIDE

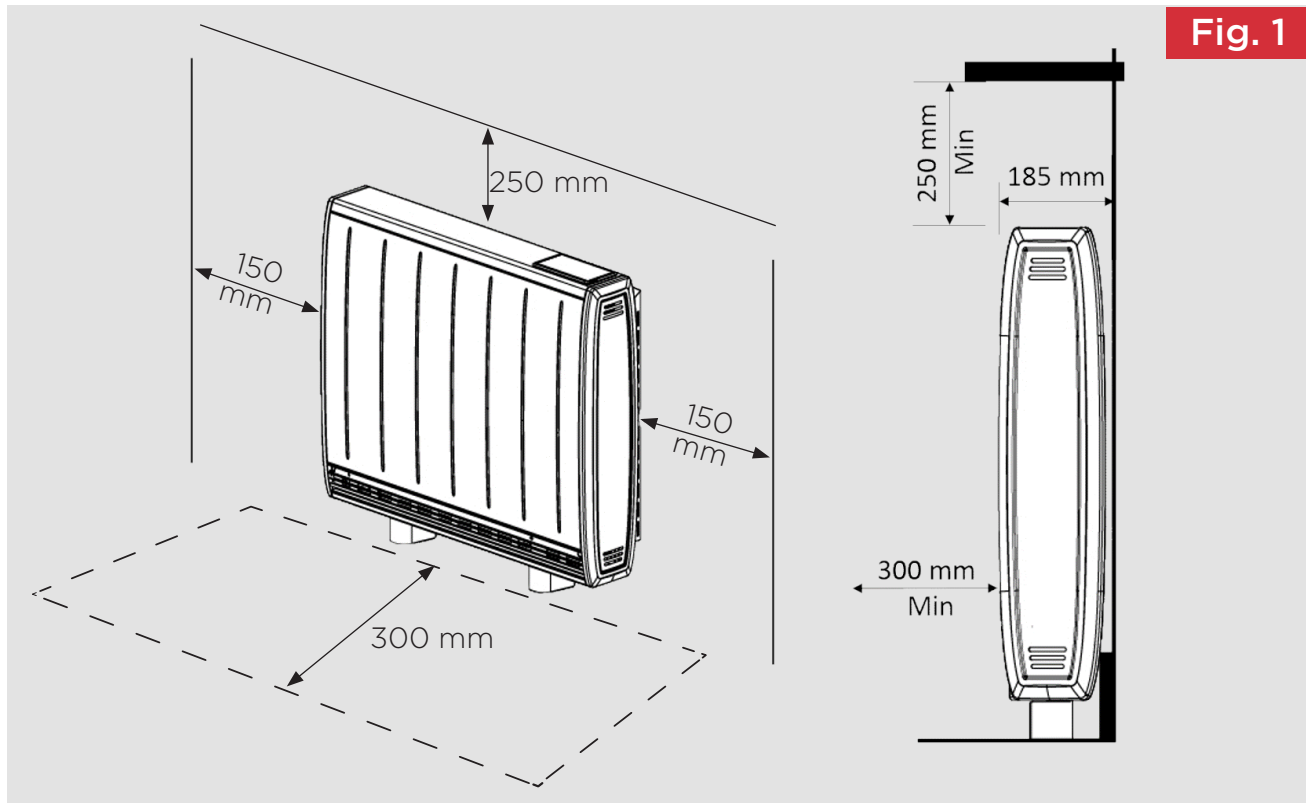
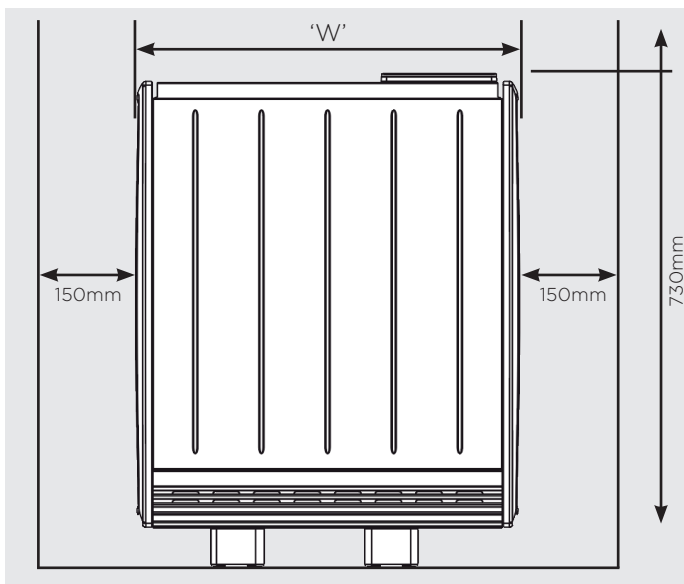

Fig. 1



QM125RF	W (mm)
QM050RF	580
QM070RF	703
QM100RF	865
QM125RF	1069
QM150RF	1069



### CAUTION

The appliance is very heavy (up to 50kg) and care should be taken when handling during installation to reduce risk of muscular or skeletal injuries.



**NOTE:**

*Read these instructions carefully before proceeding any further with the installation*

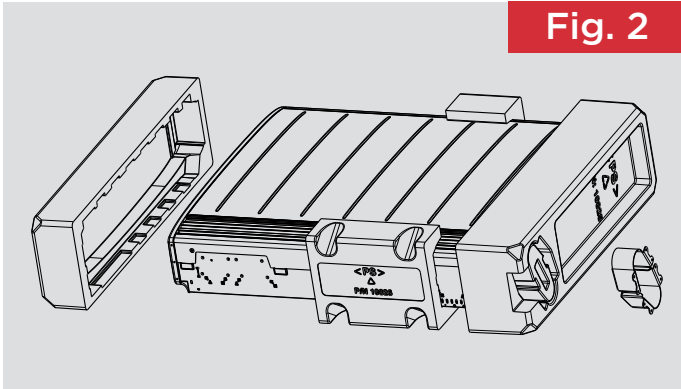

**Fig. 2**



**CAUTION**

Do not use the outer top panel or the rear heat shield to lift or carry the heater.

1. Place the heater flat on the ground with arrows printed on the base of the carton pointing upwards.

Open the carton at the bottom, slide the heater out of the carton by at least 200mm exposing the feet and the fixing kit located within the packaging on the right hand side. Remove the feet and the fixing kit. (Fig. 2)

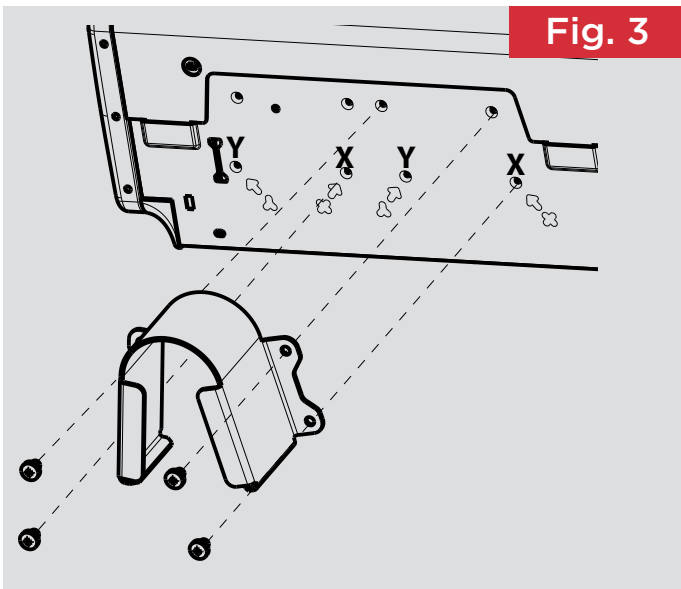

**Fig. 3**

2. Secure the feet to the heater using all the screws provided (4 per heater). For models QM050, QM070 and QM100 two locations are possible indicated by **X** and **Y** markings visible on the base of the heater.

**Ensure the feet are fixed at the location holes marked with an 'X', (Fig. 3/3B).**

However, if this is a replacement heater check the pitch of the feet and choose the appropriate fixing positions - either X or Y.

**Note - Foot screws are in the fixing kit.**

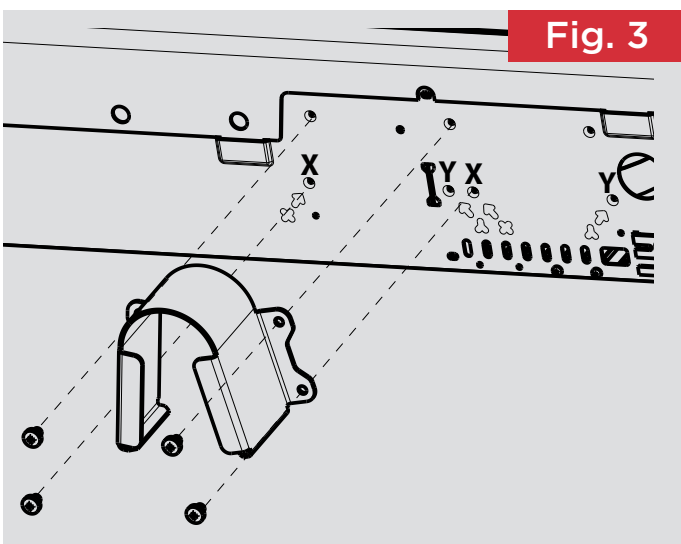

**Fig. 3**

Models	LH Foot				RH Foot			
	X		Y		X		Y	
	A	B	A	B	A	B	A	B
050	199	211	114	296	198	212	113	297
070	191	157	166	182	194	155	171	178
100	190	98	166	121	150	111	176	138
125 / 150	189	343	189	343	265	267	265	267

The Quantum feet can be fitted in two different locations (X and Y). The X and Y are stamped onto the base of the heater indicating the 2 locations

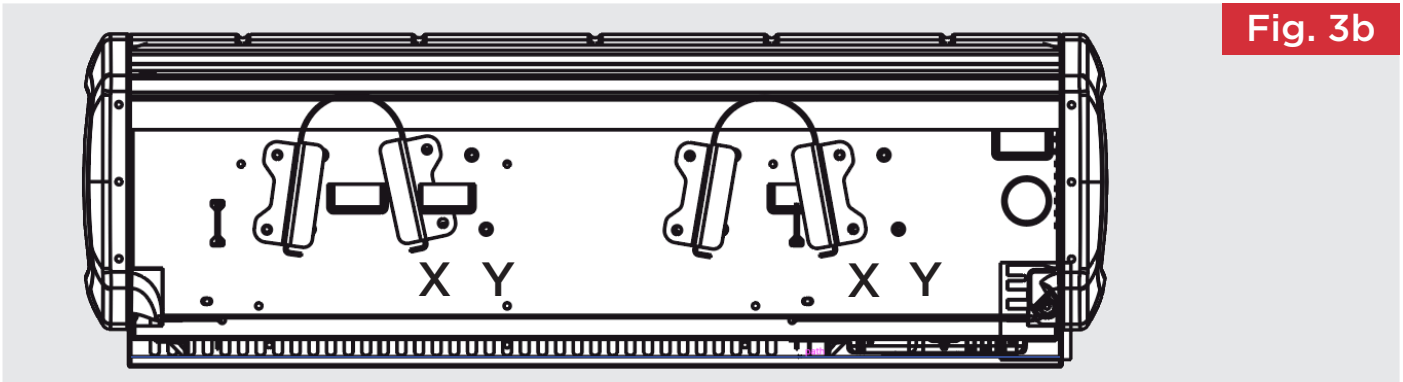

**Fig. 3b**

3. Remove the centre EPS piece and stand the heater on its feet before removing the packaging.

Dispose of the packaging in an appropriate way.



### WARNING

To avoid a fire hazard the cardboard insert within the heater core must be removed before the heater is switched on. Also ensure all polystyrene packaging is removed before the heater is operated. Leaving combustible packaging in the appliance could lead to fire and cause severe personal injury, death and damage to property.



**NOTE:**

*Read these instructions carefully before proceeding any further with the installation*

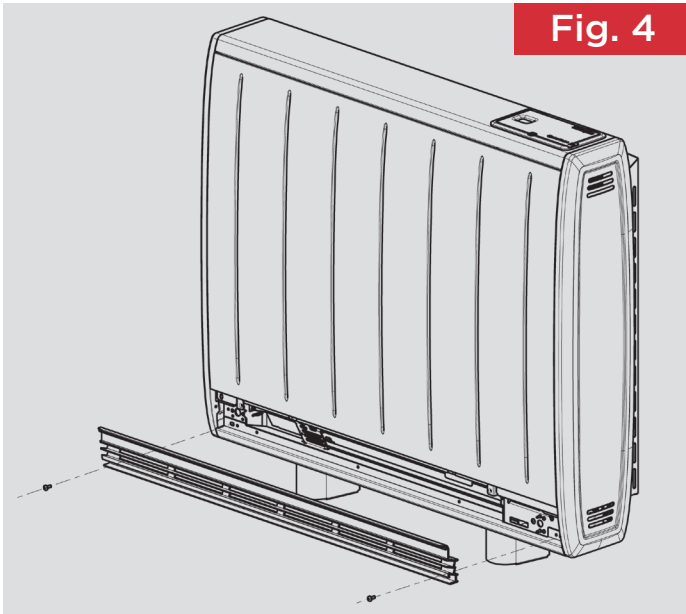

4. Lay the heater on its back before removing the screws which hold the grille panel in position. Set the grille carefully to one side to ensure that it is not damaged.

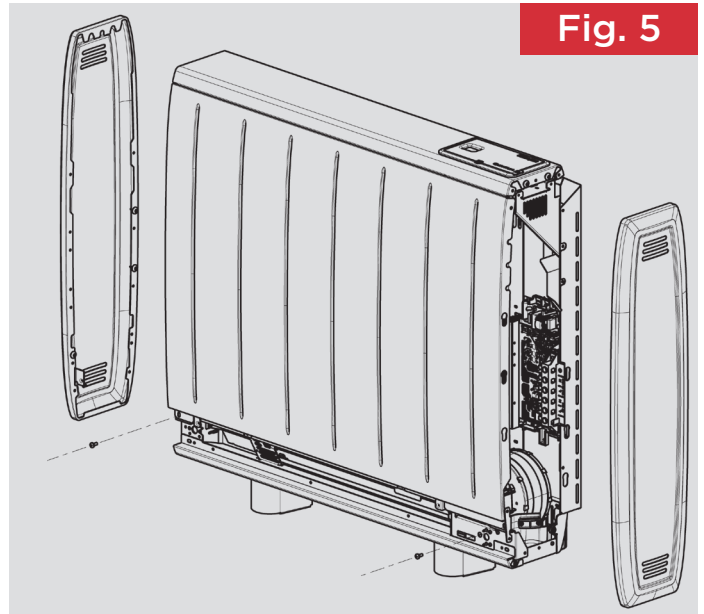

5. Remove the two screws located towards to bottom of either end of the heater, which retain the heater sides.

Push the left hand and right hand sides towards the top of the heater to release each side from its securing points.

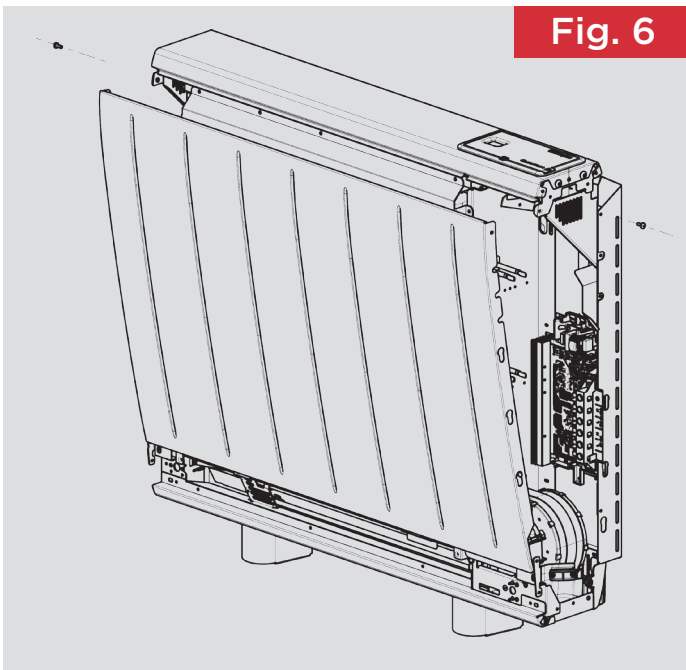

6. Remove the two screws securing the front panel, located at the upper sides of the heater, and swing the upper edge of the front panel upwards and unhook it from along the heater base.



**NOTE:**

*Retain these screws for reassembly. If misplaced, M4 X 10 Tritap screws must be used*

# Installing the Heater

**IMPORTANT** Head of wall fixing screw must be flanged pan head type and have a diameter no less than 11mm. No countersunk headed screws to be used for wall fixing.

The heater must be securely fixed to a wall. Screws with suitable wall fixings for solid walls are provided. If other wall types are encountered it is the installer who must choose the most suitable fixing.

## SUGGESTED FIXINGS

**SOLID BRICK/BLOCK:** No. 10 size high temperature resistant plastic inserts, 8mm drill bit. Drill hole 15mm deeper than plastic insert length.

**PLASTERBOARD** - If possible locate studding and use No. 10 woodscrews directly into the wood, otherwise M5 rawlplug intersets are suitable.



### NOTE:

*For other wall types (e.g. timber frame and hollow concrete), seek specialist advice.*

If the floor is carpeted then the carpet should be slit and underlay cut away to allow the feet to rest firmly on the floor. Carpet gripper must be locally removed so that the feet may rest in a level position. To maintain stability, it is essential that the heater is placed on a level surface and care should be taken to avoid irregular surfaces, such as may result from carpets or tiled surrounds partially protruding under the heater.



## WARNING

The appliance must be securely fixed to the wall. The installed appliance could weigh up to 165kg and if it falls off the wall it could cause severe personal injury or death. It is the responsibility of the installer to ensure that the appropriate wall fixing is used and that the floor is capable of bearing the full weight.



**This Heater is rated IPX4**



**DO NOT UNDER ANY CIRCUMSTANCES ATTEMPT TO MOVE OR REPOSITION THIS HEATER WITHOUT SEEKING EXPERT ADVICE. THE HEATER SHOULD NEVER BE FREED FROM THE WALL WITH ENERGY CELLS INSIDE.**



## WARNING

To avoid the risk of fire keep all combustible materials, such as furniture, pillows, bedding, papers, clothes and curtains away from the heater – minimum clearances are shown in **Fig. 1**.



**USE CAUTION WHEN INSTALLING THIS PRODUCT, UNPAINTED METALWORK CAN HAVE SHARP EDGES.**



### NOTE:

*ANY FIXING DROPPED INTO HEATER MUST BE RETRIEVED AS THEY MAY IMPACT PRODUCT SAFETY DURING OPERATION*

7. Place the heater in its final position and mark the fixing holes through the location holes visible through the back of the heater.
8. Six fixing positions must be selected for ALL models QM050RF, QM070RF, QM100RF, QM125RF and QM150RF. **Fig. 7.**

Common fixing points for all heater sizes are shown.

Mark the positions for the fixing holes towards the bottom of each slot at the two extreme ends of the slots, this allows the heater to settle once the energy cells have been fitted. **Fig. 8.**

Move the heater away from the wall, drill the holes and fit the wall fixings best suited to the application.

Secure the heater to the wall using correct quantity of screws required per model, using the appropriate screw fittings.

**NB: Do not fully tighten screws until energy cells are fully loaded to ensure full weight is on feet and not on the wall fixings.**



**NOTE:**

*UNDER NO CIRCUMSTANCES SHOULD ANY SCREWS BE REMOVED WITHOUT FIRST REMOVING ALL ENERGY CELLS FROM THE HEATER*



**NOTE:**

*NEVER FREE THE HEATER FROM THE WALL WITH ENERGY CELLS REMAINING INSIDE THE HEATER CAVITY.*

QM050RF



QM070RF



QM100RF

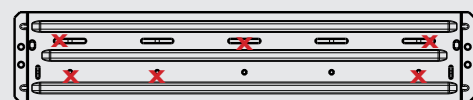

QM125RF

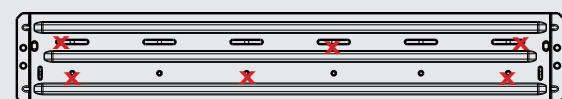

QM150RF

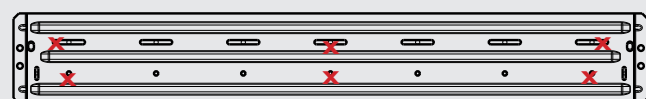

**Fig. 7**

**Fig. 8**

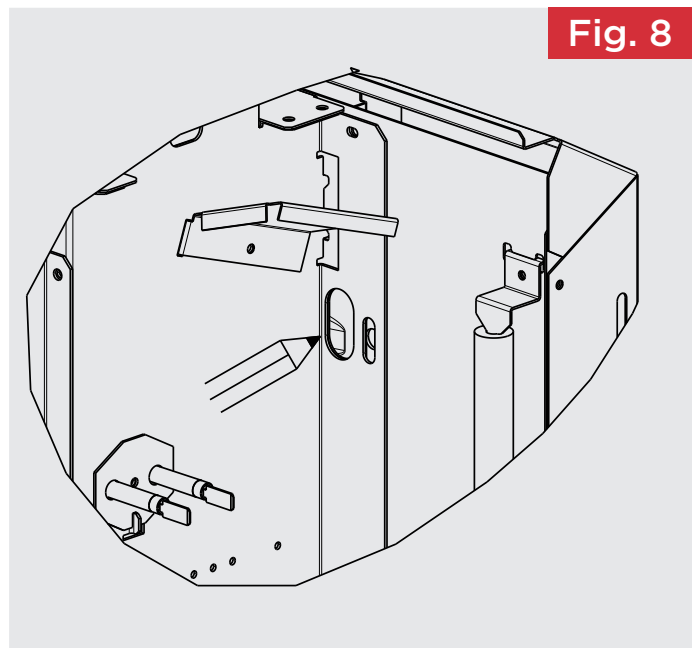

# Electrical Connections

**WARNING:** Before obtaining access to terminals, all supply circuits must be disconnected.

9. The heater leaves the factory configured to operate with two mains supplies, a 24 hour peak supply and an off peak switched supply (see Fig 9a). The heater can also be operated with a single main supply (Fig. 9b).

## Two Mains Supplies

### Dual Supply - Storage / Fan circuit (Fig.9A)

Fan Circuit = PEAK L  
Storage Circuit = OFF-PEAK L

Fan Circuit = PEAK N  
Storage Circuit = OFF-PEAK N

The brown wire connected to Live

The blue wire connected to Neutral

The earth wire should be connected into the earth terminal block marked E

**WARNING:** Terminal block minimum/maximum torque 2/2.2 Nm

### Switched Supply Terminal Block

Fig. 9a

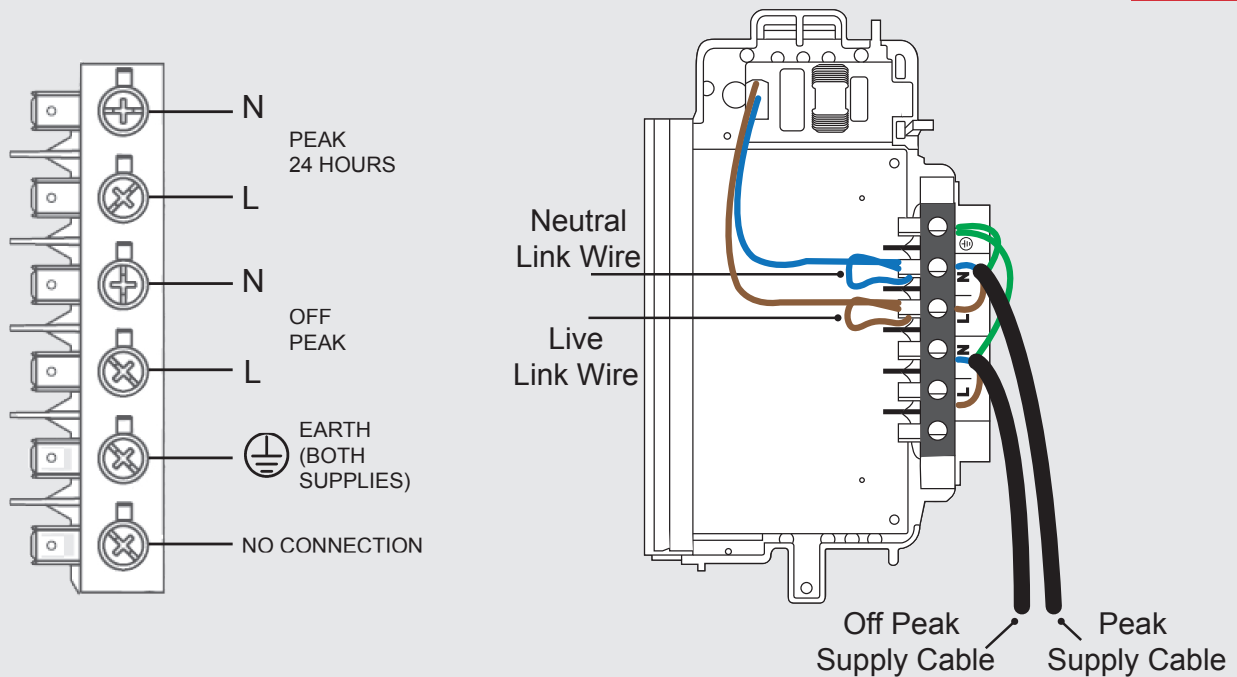

Fixed charge times can be manually programmed into the heater to tell it when to charge. By default, these charge times are set to 00:00 - 00:00 (24h charge window) meaning the heater will take charge whenever the off-peak circuit goes live.

Digital charge times can still be used with twin supply installations. This can be useful in large buildings to reduce load spikes across all storage heaters by forcing charge times to begin at different times.

To see how to set digital charge times, see page 31, then return to this page.



### NOTE:

*If the electricity tariff off-peak times change, digital charge times are set to times that off-peak energy is not available or the digital charge window is too small, the heater may not take enough charge or charge at all. The digital charge times set must match available off-peak times and allow for enough time for the heater to take a full charge.*



## Single Mains Supply

Installing your storage heater with a single electrical supply has different requirements associated. These requirements must be considered before installation. Read through this full section to verify compatibility before installation.

The single electrical supply cable must meet cable sizing requirements outlined on pages 3 and 4.

### Single Supply - Storage / Fan circuit (Fig.9B)

Fan Circuit = PEAK N  
Storage Circuit = OFF-PEAK N

The brown wire connected to Live

The blue wire connected to Neutral

The earth wire should be connected into the earth terminal block marked E

The link wires on the other side of the terminal block should be moved to match figure 9b.

### Switched Supply Terminal Block

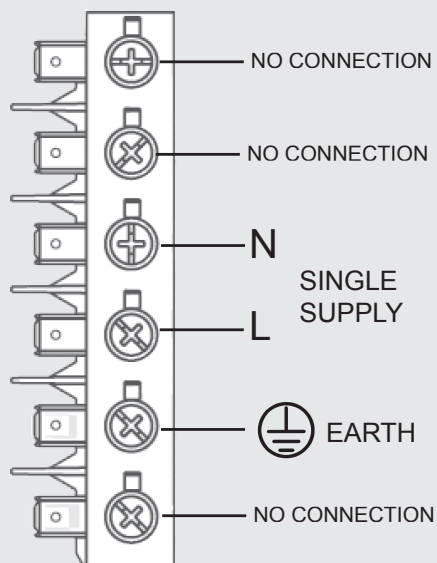

Rewire the link wires as shown in image

**Fig. 9b**

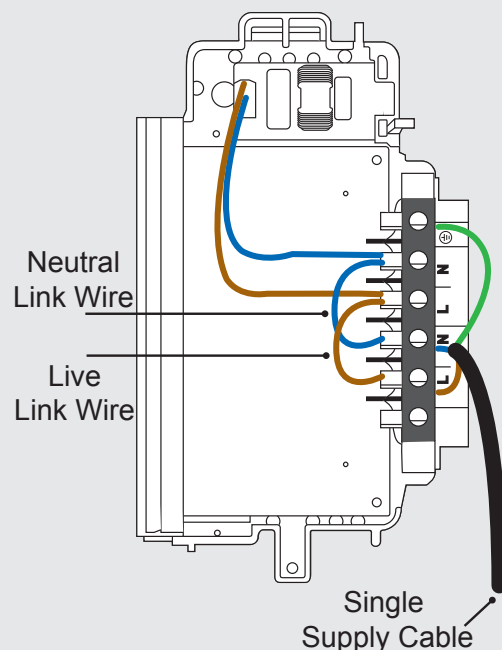

#### NOTE:

*The property energy supplier should be consulted to confirm that the meter and tariff is suitable for single supply storage heating*

The electricity tariff for the property must offer a fixed time period for off-peak energy with 'whole home switchover' whereby all wiring in the property utilises the off-peak rate when available. If the tariff is off-peak and the electricity meter has only one cable in and out, this can be assumed, if not then check with the electricity supplier.

Available fixed charge times must be manually programmed into the heater to tell it when to charge; no external timers or contactors are needed. Up-to 4 digital charge times can be set.

To see how to set digital charge times, see page 31, then return to this page.

If charge times are not programmed into the heater, the default times will be used which are set-up by default to support dual-supply installations: 00:00 - 00:00 (24h charge window).



**A 24h charge window in a single supply installation will cause the heater to charge continuously, including times when off-peak electricity is not available, resulting in larger bills.**



**NOTE:**

*As this installation relies on the accuracy of the heater's internal clock, it is good practice to check the clock annually and re-adjust if necessary. All clocks are subject to time drift and some can be up to +/- 3 sec per day. If the product is connected to the Dimplex Control system, it will be corrected daily automatically.*

The electricity meter clock time should be checked for accuracy if shown, as this will effect the appropriateness of the digital charge times that the heater will require. For example, if the tariff's off-peak times start at 00:00 but the meter's clock is inaccurate by 5 minutes, then the times programmed into the heater will not align with the meter and could be charged at peak-rate.

Daylight savings time must also be considered. Not all single supply meters adjust for Daylight Savings Time (DST). If DST is enabled on the heater then the digital charge times will adjust automatically and could become out-of-sync with the electricity meter's clock, leading to charging at peak-rate times.

When installing in single supply with a meter that does not adjust for DST, digital charge times should be set to begin an hour later and end an hour sooner than the tariff times so that the heater can still utilise DST for timer modes without affecting charge times.

Most Dimplex storage heaters can fully charge within 5 hours, and the automatic charge calculation may not always take a full charge, so on an E7 or E10 tariff this should not cause an issue as an adjusted E7 off-peak window still allows for 5 hours of off-peak charging.



**NOTE:**

Smart meters may adjust for DST with server times, in which case this would not be necessary.

Consider clock drift on the heater's internal clock when setting digital charge times. *All digital clocks have some amount of time drift and some can be up to +/- 3 sec per day. In one year, this would be +/-18.5 hours in extreme cases. It is unlikely that clock drift will be experienced to that extent, but condensing the digital charge windows set by 5 minutes at beginning and end may avoid accidental charging at peak-rate times.*

Digital charge times can also be used in single supply installations to stagger charge start times across many storage heaters in a building. This can be used to avoid sudden surge loads, especially in large buildings.

### Variable charge time tariffs

Some energy suppliers offer variable off-peak tariffs that can work specifically with Dimplex Control supported storage heaters. In this kind of installation, digital charge times do not need to be manually programmed into the heater, the energy supplier will do this automatically via the Internet and Dimplex Control platform.



**NOTE:**

*If connectivity is lost in this set-up, the heater will automatically change back to the 'offline' or 'non-variable' charge times that the energy supplier sent to the heater during setup. The supplier should recognise that the heater is charging within fixed charging times and charge the appropriate rate. If there are any discrepancies, the energy supplier should be contacted.*

**10.** The mains cable entry and terminal block will be visible in the centre of the cavity at the right hand side. Insert the mains cables through the cable gland at the bottom of the heater in readiness for connection (**Fig. 10**).

Only heat resistant ordinary polyvinyl chloride sheathed flexible cord should be used, the following codes apply;

**IEC: 60227 IEC57 or CENELEC: H05V2V2-F**

**Maximum Cable Sizes**

Peak mains cable 1.5mm<sup>2</sup>

Off-peak mains cable 2.5mm<sup>2</sup>

Single Supply mains cable 2.5mm<sup>2</sup>



## CAUTION

If the supply cord becomes damaged, it must be replaced by a suitably qualified individual in order to avoid a hazard.

The mains cable should be stripped to a length of 8mm allowing 10mm extra for cutting off/trimming. Twist the stripped cable slightly and then trim to a length of 8mm, folded over and inserted into the receptacle with no insulation trapped and likewise no conductors showing, hence why the strip length is critical. The terminal block screw should tighten down onto the formed loop and not cut through it.

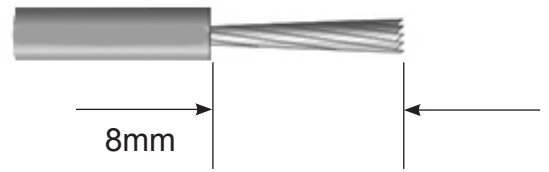

### CAUTION

Ensure that the terminal block is not tightened on the cable insulation as this may lead to local overheating at the connection which may lead to a hazard.



### CAUTION

The terminal block should be tightened to a minimum torque of 2Nm and a maximum torque of 2.2Nm.



### CAUTION

If the mains connection is to be made from the left side it should be secured to the back of the heater using cable ties.

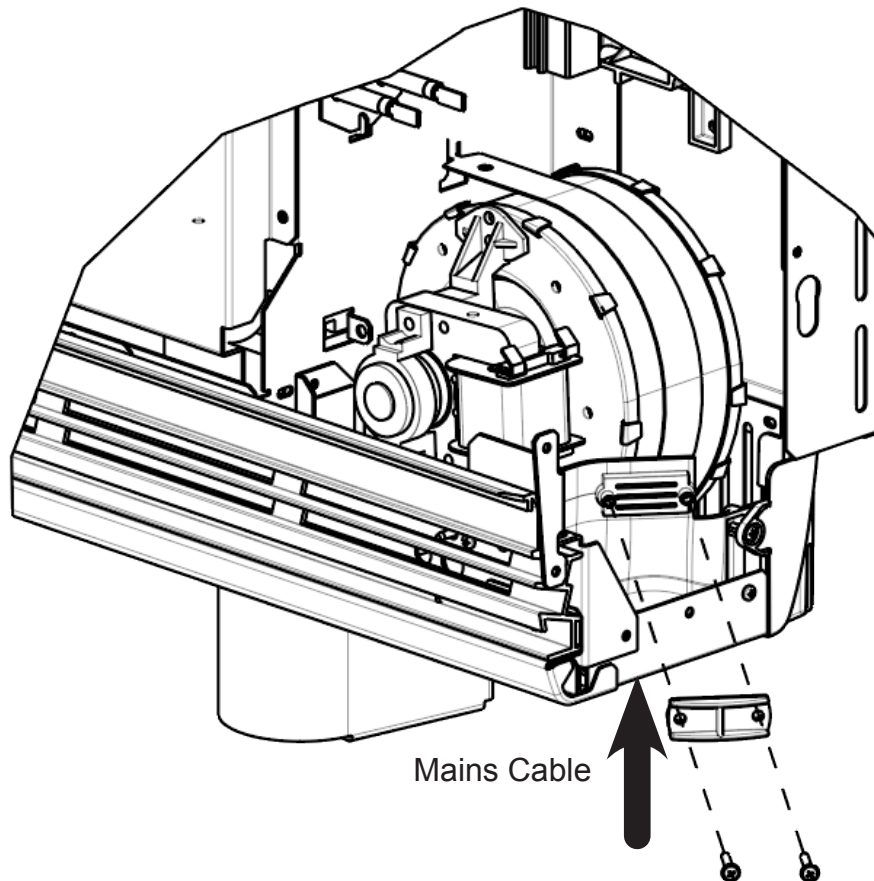

Fig. 10

Fig. 11

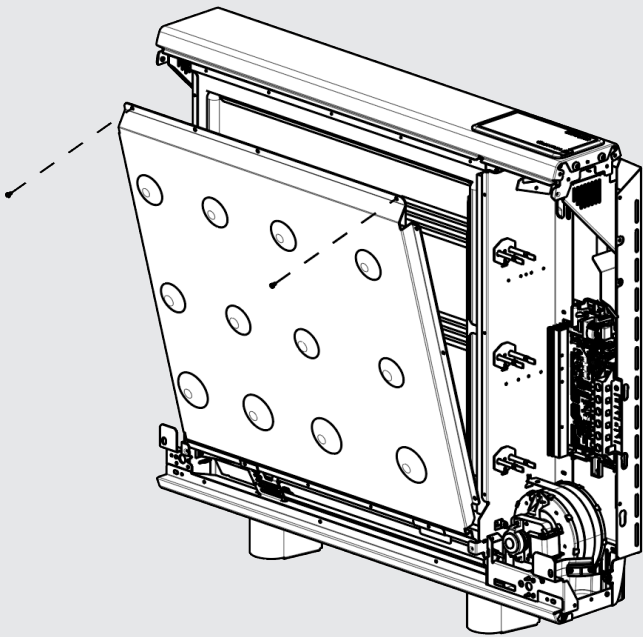

Fig. 12

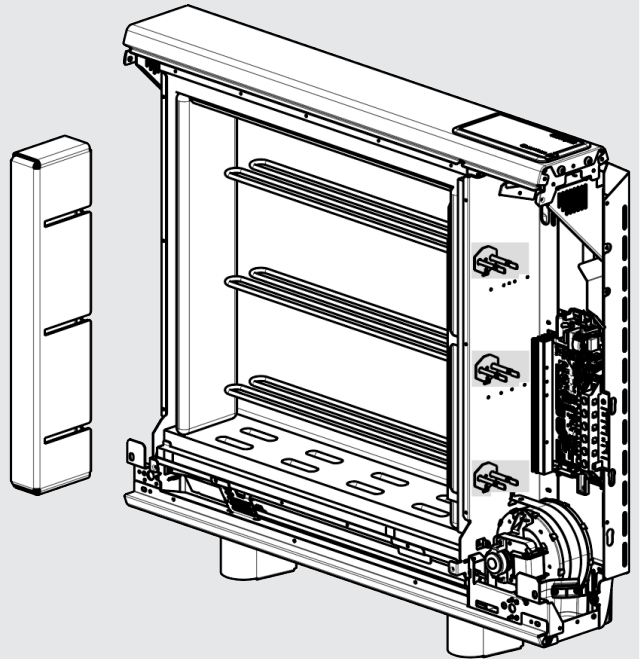

Fig. 13

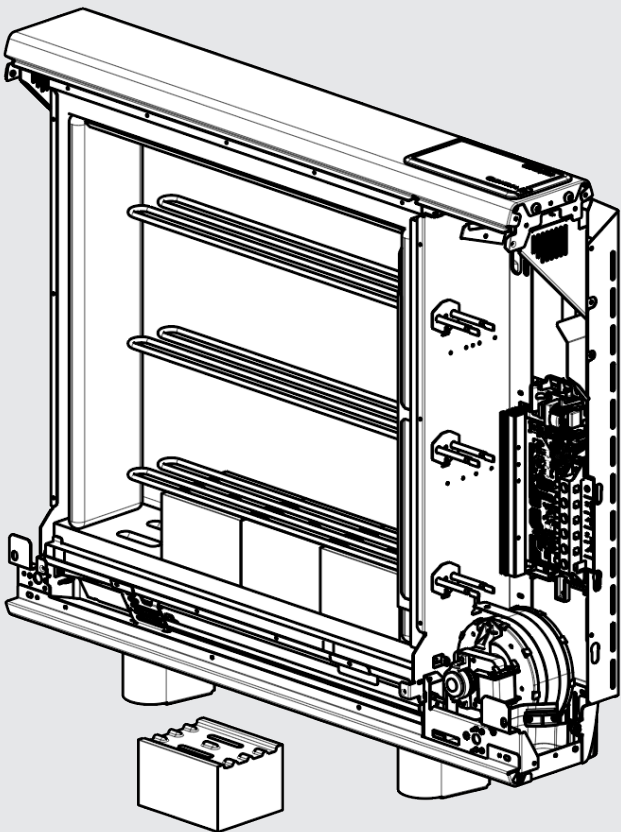
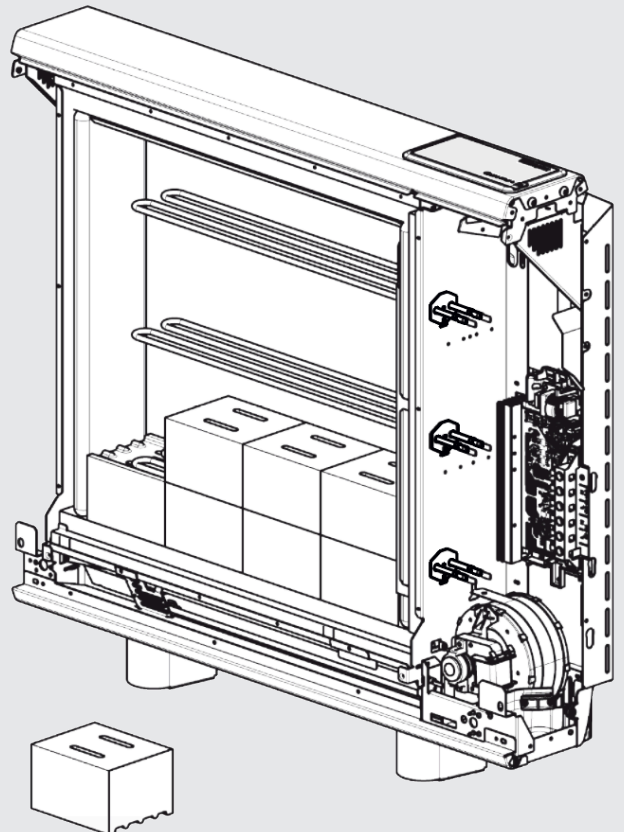

Fig. 14



## Building the Heater Core

11. Remove the inner front and insulation to gain access to the core of the heater.  
Lay the inner front carefully to one side to ensure it is not damaged. (Fig. 11)



### CAUTION

The edges of the inner front are sharp and can cause cuts to hands. Ensure the appropriate PPE is used when handling this panel.

12. Remove the cardboard element support and dispose of. (Fig. 12)



### CAUTION

The cardboard packaging is combustible and will go on fire if it is not removed.

#### Energy Cells

The energy cells are supplied separately to the heater in packs of three.  
The item code is 047243.



**Energy Cells should be handled with care due to the weight and risk of personal injury.**



**Make sure that energy cells are kept dry. Energy cells should not be exposed to moisture and not installed if this has occurred.**

13. The energy cells have several grooves on one surface for locating around the elements. The two slots through the centre of the energy cell create the air passages within the core.



Angle the element upward to fit the energy cell. Position the first energy cell of the bottom row to the right, firmly pressed against the side insulation with the element grooves facing upwards and fitting neatly around the element.

Position the second energy cell in the row against the left-hand insulation. Place the remaining energy cells between the first and second in the row. (Fig. 14)



**DO NOT DISCONNECT THE ELEMENT TERMINALS**

In addition ensure the slots for the air passages line up with the holes in the base insulation.



#### NOTE:

*The element tails must extend no further than 30mm into the right hand chamber*

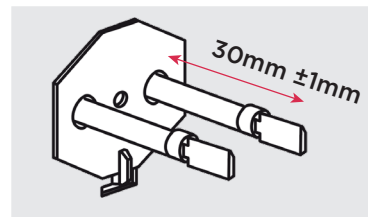

Fit the remaining energy cells to the bottom row, being careful not to damage or dislodge the element.



#### NOTE:

*The bends in the element locate around the grooves in the energy cell to secure the element.*

14. Position the second row of energy cells on top of the first but this time the energy cells must be upside down ensuring the grooves are positioned over the elements. (Fig. 14)

**Fig. 15**

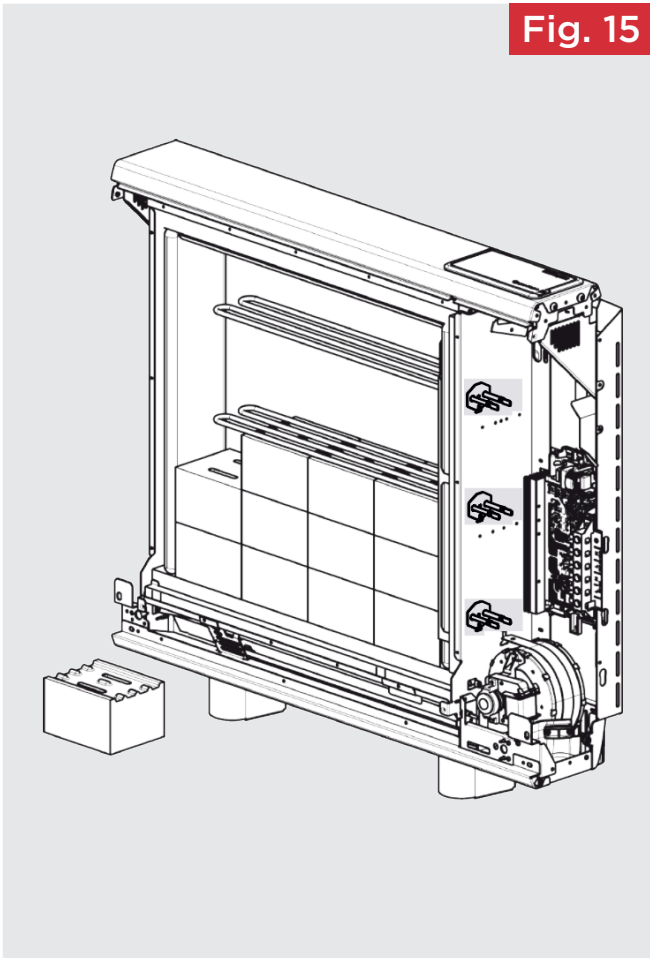

**Fig. 16**

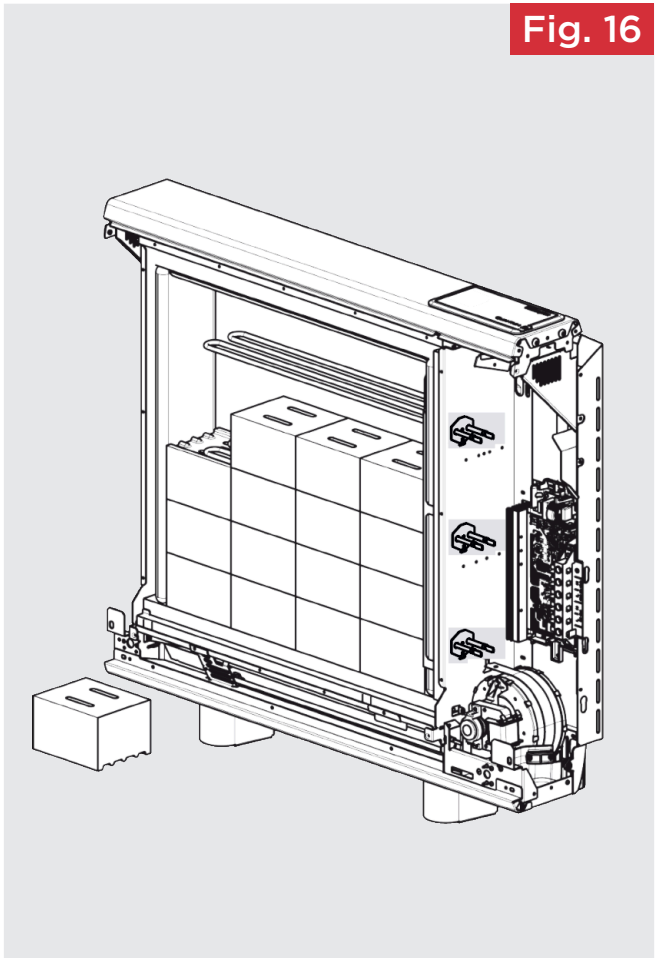

**Fig. 17**

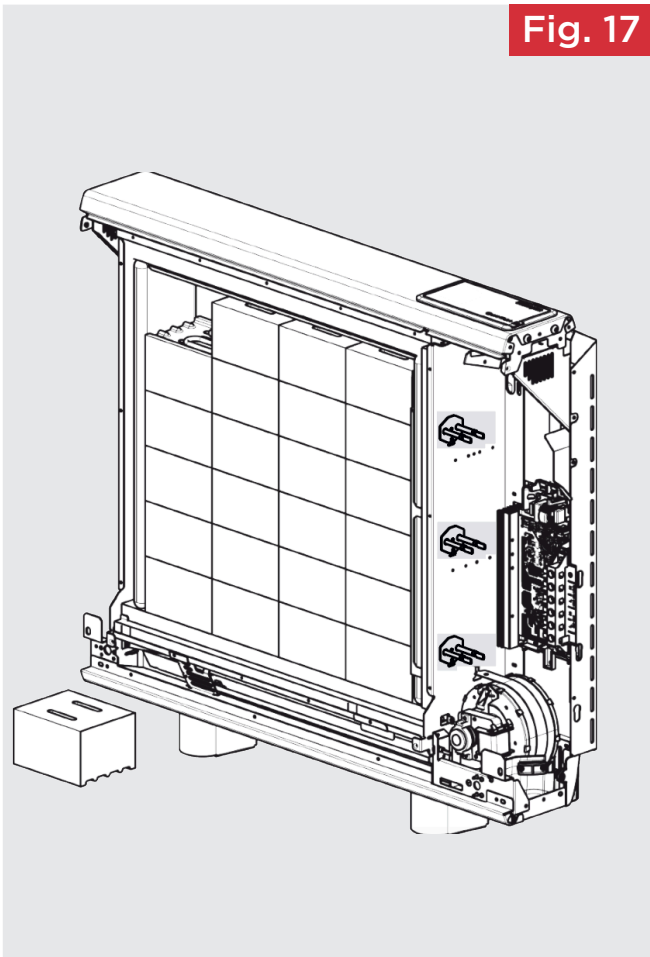

**Fig. 18**

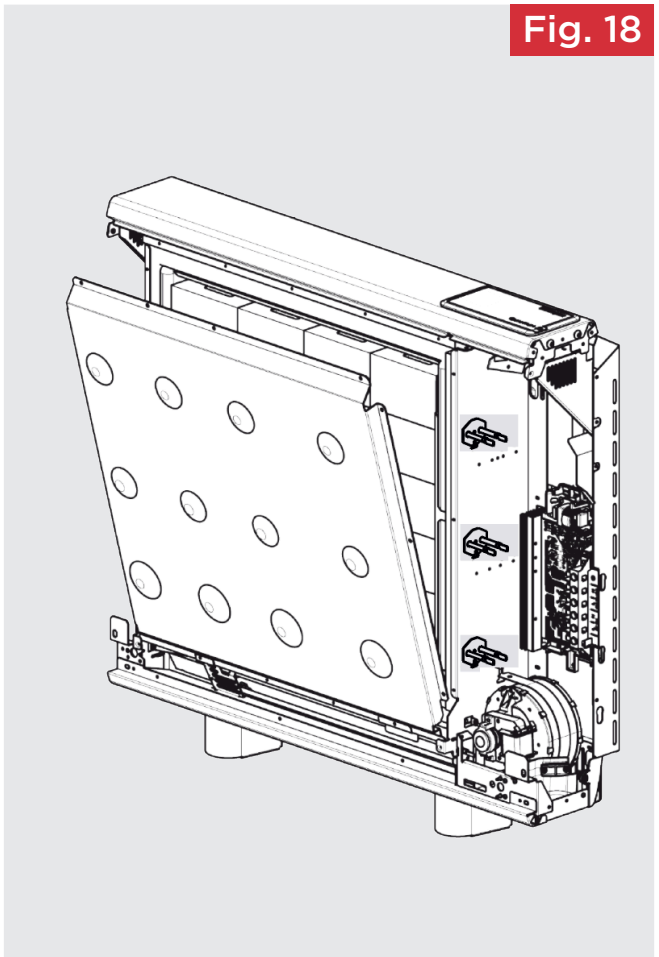

15. The third row of energy cells is positioned in a manner similar to the first row. Again be careful not to damage or dislodge the element. (**Fig. 15**)
16. Fit the fourth row of energy cells above the third row in the upside position. Again, the first energy cell should be positioned firmly against the right-hand insulation, and the second energy cell should be positioned firmly against the left-hand insulation. (**Fig. 16**). Repeat for the fifth and sixth rows of energy cells built around the third element to complete the core build.
17. Remember the top row of energy cells must be fitted upside down. (**Fig. 17**)

Check that all the energy cells are secure and evenly located.

18. Close the core by refitting the inner front panel complete with insulation, starting at position and working clockwise. (**Fig. 18**)

Ensure the bottom tabs are located inside the chassis and that the screws are tightly secured down each edge.

Ensure the screws retaining the heater to the wall are fully tightened, once the energy retention cells are fully loaded. (**Fig. 7, page 15**)



#### **IMPORTANT**

Double check all mains connections are secure and excess cable is restrained and not in contact with any of the heater casing.

**ON NO ACCOUNT SHOULD ANY SURPLUS CABLE BE PUSHED INSIDE OR BEHIND THE HEATER.**

**Once installed DO NOT attempt to reposition the heater without first unloading the energy cells.**

#### **Reassembly**

To replace the bottom grille and front panel, reverse steps **Figs. 4, 5 & 6** (page 13) of these instructions under the section headed **Preparation**.

Ensure all fixings are secure.

## First Time Power-On

A setup wizard will display when the product is powered on for the first time. This will set the following:

- Time, Date, Daylight Savings Time
- Sound On/Off

For information on using the Heaters controls, refer to page 26. The Heater will then take the User to the Home Screen with the 'Out All Day' Timer Mode active.

### **IMPORTANT**

During initial heat-up, some odour may be emitted due to the newness of materials used in manufacture. This is normal and will disappear after a short period of use, It is however advisable to keep the room well ventilated



# Dimplex • Control

This product is Dimplex Control capable \* \*\*.

Control and monitor your heating and hot water with Dimplex Control. Group heaters into zones to easily control and track their energy usage. Any time. Anywhere.

**Search for Dimplex Control on your device's app store.**



*\*Requires additional hardware. Sold separately. Visit [Dimplex.co.uk](http://Dimplex.co.uk) for more information.*

*\*\*A Dimplex Hub is required for this product to connect to Dimplex Control. For instruction on setting up Dimplex Hub, please refer to the manual. Manuals can be downloaded at [Dimplex.co.uk](http://Dimplex.co.uk).*

# Operation

**WARNING:** FAILURE TO FOLLOW THESE OPERATING INSTRUCTIONS MAY RESULT IN INJURY AND/OR DAMAGE

The controls are located on the top of the heater consisting of a display screen and three buttons and a Dial.

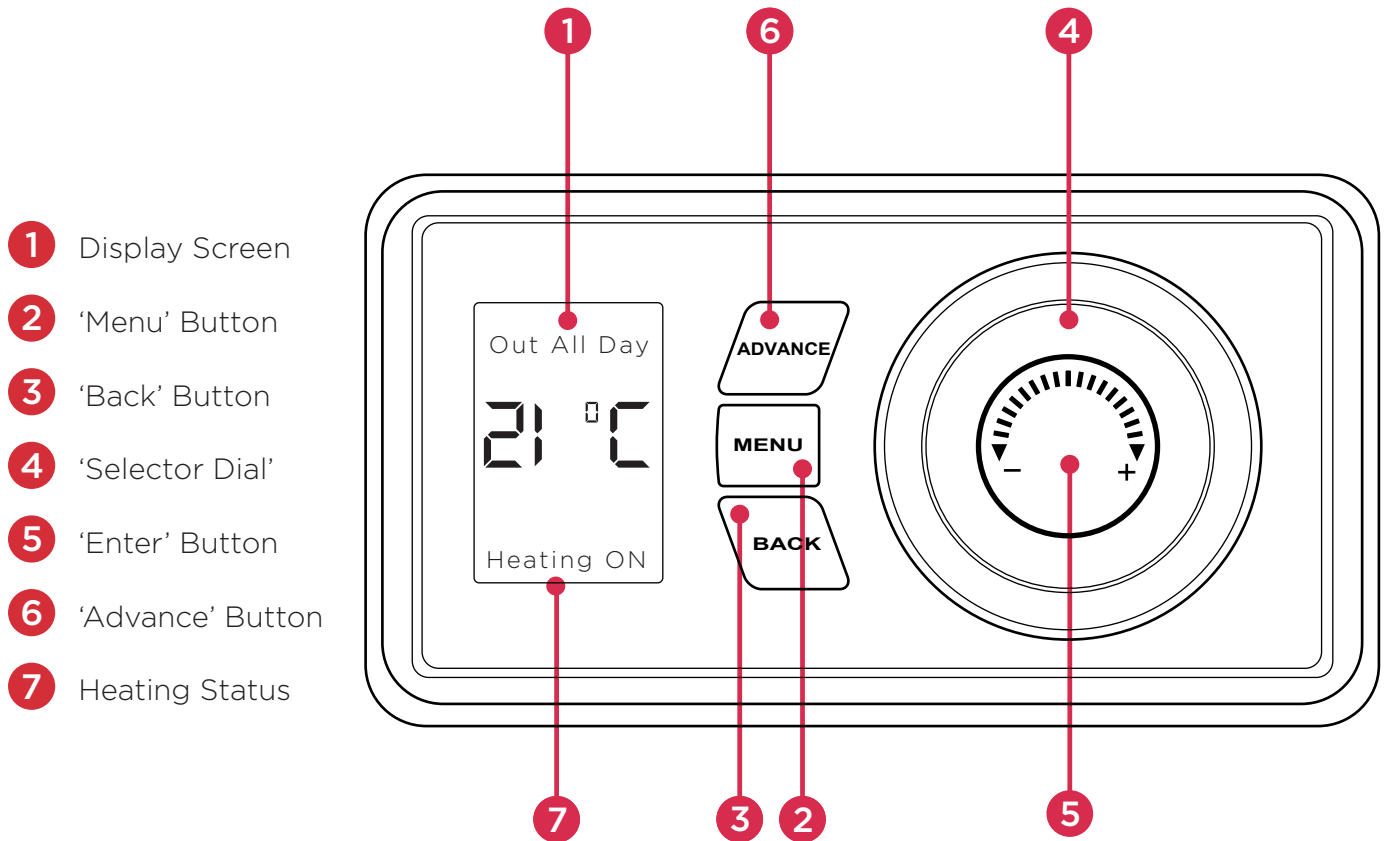

The heater is fitted with an adjustable thermostat enabling the room temperature to be controlled. The minimum room temperature is 7°C. The maximum temperature is set to 30°C by default. A temperature of 21°C is a common comfortable room temperature.



**NOTE:**

Your heater may produce some noise during operation. This noise is caused by the low noise fan and expansion and contraction of the metalwork as it changes temperature, and is normal for this type of product. Whilst the noise produced is usually very quiet, certain environmental factors can make it more noticeable, such as hard flooring or minimal furnishings.



**NOTE:**

Should the heater fail to operate, this may be due to the room temperature being higher than the thermostat setting.

The heater controls can be easily adjusted by using the **Dial** and buttons on the User Interface.

1. The Home Screen shows the options available at each stage of adjustment. Here the current target room temperature is displayed along with the mode of operation. Any use of the Advance function will be displayed here, and pressing the **Dial** will show the functions which are enabled.



The currently active mode of operation is displayed at the top of the screen e.g. 'Out All Day' timer.

When the heater is in a timer profile and trying to achieve or maintain a room temperature, 'Heating On' will be displayed, otherwise, 'Heating Off' will be displayed. The words 'Heating On / Off' will not be displayed in a manual mode of operation

When the controller buttons have not been pressed for a long period of time, the display will 'sleep' and the text will disappear. The heater is still on and active in whatever Mode it was set to.

2. **Menu** - Displays the Main Menu;
  - Boost - Activate Boost Mode
  - Modes - Set the mode of operation.
  - Settings - Time/Date, Temperature units etc.
3. **Back** returns to the previous screen.
4. Rotate the **Dial** to navigate through the menus and adjust the required room temperature on the main screen. The screen colour changes based on the temperature selected, showing deep blue through to bright red.
5. Press the **Dial** to enter sub menus and to confirm actions.
6. The **Advance** button is only used when a Timer Mode is active, it allows the timer schedule to be changed temporarily by forcing a 'Heating On' period to begin or end early.

# Settings

To navigate to the Settings Menu, from the Home Screen:

Press the **Menu** button to access the Main Menu. Rotate the **Dial** to highlight 'Settings', then press the **Dial**. Each of the following headings relate to an item in the Settings Menu.

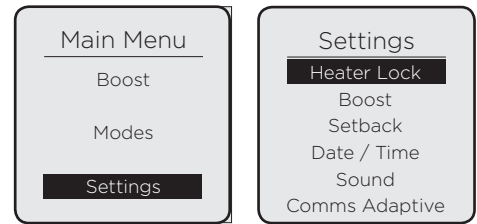

## Heater Lock

### Set Lock

Heater (PIN) Lock can be enabled here by highlighting 'Heater Lock' and pressing the **Dial** to enter the Heater Lock menu. Highlight 'Set Lock', press the **Dial**, enter a 4-digit PIN code, then pressing the **Dial** to lock the heater.

## Lock Settings

Before PIN Lock is enabled, the User can select 'Lock Settings' to enable/disable the Advance and/or Boost functions, as well as enable/disable modification of the Boost Temperature and Boost Duration. See below.

## Boost Rule

Three settings can be modified within this Menu:

- Enable / Disable - The 'Boost' Menu Item can be Enabled/Disabled while PIN Lock is active.
- Temperature Rule - Modifiable Boost Temperature while PIN Lock is active
  - Enable - While Boost is active, the User can modify this value as they normally would
  - Disable - Default value will be loaded. When the user tries to modify the value, the UI will show the following text: 'Disabled'.
- Duration Rule - Modifiable Boost Duration while PIN Lock is active.
  - Enable - While Boost is active, the User can modify this value as they normally would
  - Disable - Default value will be loaded. When the user tries to modify the value, the UI will show the following text: 'Disabled'

## Advance Rule

- Enable / Disable - This setting allows the User to Enable or Disable the **Advance** button while PIN Lock is active.

## **Boost Settings**

### **Default Boost Target Temperature**

This is the default Boost Target Temperature that is used when 'Boost Mode' is activated.

### **Max Boost Duration**

This is the maximum length of time that the user is able to activate 'Boost' for. Shown in minutes (when under an hour) or hours (if over an hour) in the following increments: 30 mins, 1 hour, 2 hours, 3 hours, 4 hours.

The value chosen will be the max allowed when boost is activated. This is required for the Boost Duration Lock to function.

## **Setback Settings**

**Setback** is a function that only modifies Timer Mode operation. When Setback is enabled it overrides any 'Heating Off' period to maintain a constant temperature.

This can be used to prevent the room temperature from falling below a minimum value while there is no demand for heat ('Heating Off').

The value of this temperature is restricted to a value between 8 and 19 °C. This is because Setback should not be treated as a regular 'Heating On' period.

## **Date & Time Settings**

This allows the Time, Date and Daylight Savings Time settings to be modified.

## **Sound Settings**

Audio feedback when the user presses a button can be enabled or disabled here.

## **'Comms' (Communications) Settings**

This allows Wireless Connectivity features to be enabled or disabled. Entering this menu item will display a list of available communications methods to that heater.

## Adaptive Settings

### Open Window Detection

This is a global setting that can interrupt any active mode. Activating this setting enables Open Window Detection to switch the Heater to a 'Heating Off' state if it detects an open window in the room it's operating in.

### Adaptive Start

Adaptive Start is predictive function that only modifies Timer Mode operation. This function models the heating characteristics of the room and uses that information to pre-heat the room for only the time required to achieve the Target Temperature by the start of the 'Heating On' period.

For example, with Adaptive Start off, the 'Heating On' time is the time that the Heater will begin to try and achieve the Target Temperature. With Adaptive Start On, the Heater will begin to heat the room before the User-defined Heating On time so that the Target Temperature is achieved when the User defined the 'Heating On' start time.



#### **NOTE: Adaptive Start**

*This is a continuously learning function and will be affected daily by changes in the heater's environment. The heater will take into account the starting temperature of the room so pre-heating should remain accurate.*

*It is important that if multiple heaters are installed in one room that all heaters have the Adaptive Start (AS) function enabled. If this is not the case, heaters with AS enabled will pre-heat the room to the desired target temperature before the heaters with AS disabled attempt to output heat.*

*It is likely that if two heaters are required in one room, that the output from one heater may not be sufficient to heat the room alone. This may cause the pre-heat time calculation to extend to a large degree if the heaters do not all have AS enabled. This may lead to heat at unwanted times and excessive wear to some heaters.*

*A two-hour limit is enforced on the calculation, however, if all heaters have AS enabled and pre-heating takes over one-hour, extreme environmental factors may be affecting the calculation or the heaters may be under sized for the room. Please contact us for support if your pre-heat time seems excessive.*



#### **NOTE: Open Window Detection**

*In environments where the product may read sudden decreases in temperature, this feature may activate in error. This can occur in drafty or poorly insulated environments as well as if the heater is undersized for the room. This feature should be disabled using the instructions above if activating for reasons other than the intended purpose. If you think that your environment is not as described here and this feature is activating, please contact our customer care team with the details on the rear page of this document.*

# Advanced Settings

These settings can be used to significantly change the operation of the heater. While useful for very specific requirements, there is a much higher risk of User error and unintended consequences of changing these settings compared to the top-level settings menu. It is recommended that these settings are only modified by trained professionals.

To navigate to the Advanced Settings menu, from the home screen:

Press and hold **Advance** and **Menu** buttons for 5 seconds.

Each of the following headings relate to an item in the settings menu.

## Temp Settings

Temp Units (Temperature Units)

This setting defines which temperature units are displayed on the heater. The default is °C, but °F can be set. When °F is selected, the heater will convert °C values to °F and round to the nearest number.

## Charging Settings

If the output of the storage heater is not able to deliver the required heat demand throughout the day, it is possible to force the heater to store additional energy. This will manually adjust the charge calculation to store more electrical energy during the charging period.

This setting displays the available charge times for the Heater to store off-peak energy. It is presented like the Timer setup screen, but without a Target Temperature or Day Selection. This allows the Installer to set up to 4 charging On and Off times.

## Charge Times

This setting displays the available charge times for the Heater to store off-peak energy. It is presented like the Timer setup screen, but without a Target Temperature or Day Selection. This allows the Installer to set up to 4 charging On and Off times.

Default charge times (Standalone) are:

<i>Period 1</i>	<i>00:00 - 00:00</i>
<i>Period 2</i>	<i>00:00 - 00:00</i>
<i>Period 3</i>	<i>00:00 - 00:00</i>
<i>Period 4</i>	<i>00:00 - 00:00</i>

Charge times should remain at the default settings (as shown above) for twin supply installations. This setting should only be used in single supply installations. Values entered here always take precedent.

## Service Settings

These items are for use by service personnel only. The settings effect the accuracy and energy usage of the heater and should only be modified by a professional.

### Room Temp (Temperature) Offset

Allows the manual adjustment of electronic room thermostat reading by +/-3.0°C

### Slave Heater Mode

This setting modifies the charge algorithm to prevent under-charging when enabled. If more than one heater is installed in the same room, it is recommended that the smallest capacity heater(s) is set as a slave. This is disabled by default.

## Heat Source Setting

With this setting, it is possible to restrict use of peak rate energy for each of the following modes:

- Timer Mode
- Boost Mode
- Setback Mode



### NOTE:

*Increased use of peak rate electricity could lead to increased running costs*

## Factory Reset

This setting allows the User to restore the default values to all settings. Returning the product to the same state that it left the factory.



# Error Codes

Error codes are to be defined as a list. Each error code must be defined as a perimeter that Central Control can read.

Fault Code	Description
20	Component thermistor hardware fault
20	
21	
22	
23	
24	
30	Component overheat
32	
33	
34	
40	Internal serial comms error
41	Heating element fault
50	Open window detected
51	Low water
52	Heat output disabled
53	Time loss error
54	Occupancy sensor not detected
55	Unknown error
60	Wireless communication module error
61	Hub connection error

# Battery Replacement

## IMPORTANT:

Before replacing the battery ensure the heater is isolated from the electricity supply.



## NOTE:

*Battery should be disposed of in an appropriate manner*

This product is fitted with a replaceable battery in the controls. To replace the battery, follow the steps below:

1. Push a small flat headed screwdriver into the opening on the right hand side of the User Interface (**Fig. 19**) to release the clip.
2. Lift the User Interface module out away from the heater being careful not to damage the cable
3. Unscrew the battery cover (**Fig. 20**) to gain access to the battery holder.
4. Use a small flat headed screwdriver to remove the battery from the battery holder and replace the battery.
5. Replace the battery access cover.
6. Push the User Interface module back into place, again avoiding damage to the cable.

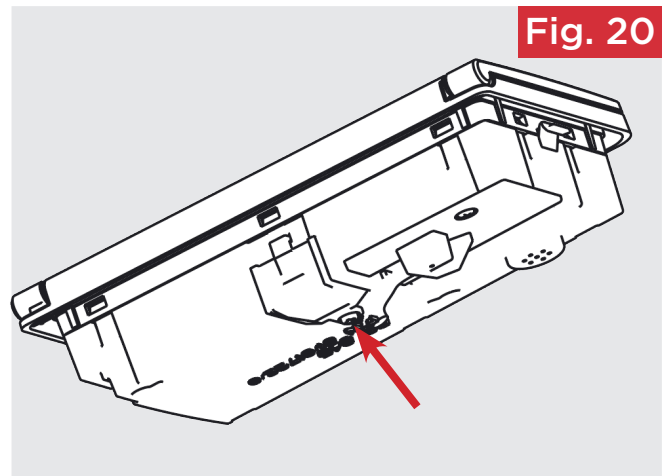
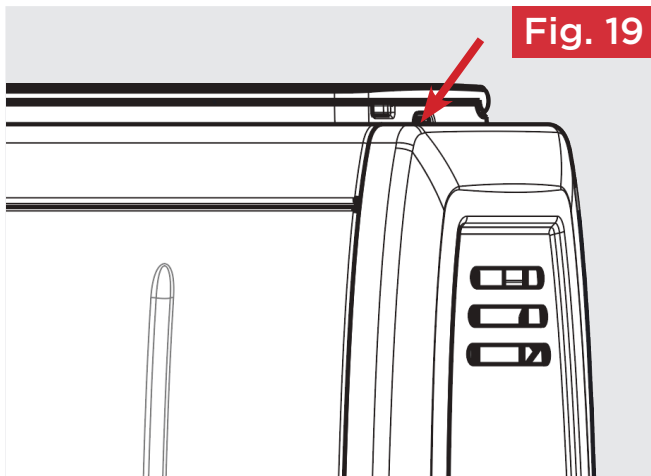

## Important

During the initial operation, some odour may be noticed due to the newness of materials used in manufacture. This is normal and will disappear after a short period of use. It is however advisable to keep the room well ventilated

## Cleaning

**WARNING - ALWAYS DISCONNECT FROM THE POWER SUPPLY BEFORE CLEANING THE HEATER.**

Before commencing cleaning, isolate the heater from the electrical supply and allow it to cool. The outside can be cleaned by wiping it over with a soft dry cloth. Do not use abrasive cleaning powders or furniture polish, as this can damage the surface finish.

# Guarantee

## What does a Dimplex Guarantee cover?

Dimplex products deliver reliable service for use in dwellings. All Dimplex products are individually tested before leaving the factory.

If you are a consumer and you experience a problem with your Dimplex product, which is found to be defective due to faulty materials or workmanship within the Guarantee Period, this Dimplex Guarantee will cover repair or - at the discretion of Dimplex - replacement with a functionally equivalent Dimplex product.

The Dimplex Guarantee Period is two calendar years from the date of purchase of your Dimplex product, or the date of delivery of the product, if later. The Dimplex Guarantee is conditional upon you providing the original purchase receipt as proof of purchase. Please therefore retain your receipt as proof of purchase.

If you do experience a problem with your Dimplex product please call the Helpline on +44 [0]344 879 3588 or visit <https://www.dimplex.co.uk/support>. For ROI please email [serviceireland@glendimplex.com](mailto:serviceireland@glendimplex.com) or call +353(0)1 842 833. We will need details of your Dimplex product, its serial number and a description of the fault which has occurred. You can find the model number and serial number for your Dimplex product on the heaters' side. Once we receive your information and proof of purchase we will contact you to make the necessary arrangements.

If your Dimplex product is not covered by this Dimplex Guarantee there may be a charge to repair your product. However, we will contact you for agreement to any charges before any chargeable service is carried out.

## What is not covered by a Dimplex Guarantee?

The Dimplex Guarantee does not cover any of the following:

- Any fault or damage to your Dimplex product due to faulty materials or workmanship occurring outside the two year Guarantee Period.
- Any fault or damage occurring to any pre-owned Dimplex product or to any other equipment or property.
- Accidental damage to your Dimplex product or damage to your Dimplex product from external sources (for example, transit, weather, electrical outages or power surges).
- Fault or damage to your Dimplex product which is:
- Not due to faulty materials or workmanship or which is due to circumstances outside Dimplex's control.
- Caused by use of your Dimplex product for anything other than normal dwelling usage in the country where it was purchased.
- Caused by any misuse, abuse or negligent use of the Dimplex product, including but not limited to any failure to use it in accordance with the Installation Instructions supplied with the product.
- Caused by any failure to assemble, install, clean and maintain your Dimplex product in accordance with the Operating Instructions supplied with the product unless this was carried out by Dimplex or its authorised dealers.

- Caused by repairs or alterations to your Dimplex product not carried out by Dimplex service personnel or its authorised dealer(s).
- Caused by use of any consumables or spare parts for your Dimplex product which are not Dimplex specified.

### Terms and Conditions

- The Dimplex Guarantee is valid for Dimplex from the date of purchase of your Dimplex product from a recognised retailer in the country of purchase and use, or the date of delivery of the product if later, always provided the original receipt has been retained and is produced as proof of purchase.
- You must provide to Dimplex or its authorised agents on request the original receipt as proof of purchase and - if required by Dimplex - proof of delivery. If you are unable to provide this documentation, you will be required to pay for any repair work required.
- Any repair work under the Dimplex Guarantee will be carried out by Dimplex or its authorised dealer(s) and any parts that are replaced will become the property of Dimplex. Any repairs performed under the Dimplex Guarantee will not extend the Guarantee Period.
- Any replacement of you Dimplex product by Dimplex during the Guarantee Period will not start the Guarantee period afresh.
- The Dimplex Guarantee does not entitle you to recovery of any indirect or consequential loss or damage including but not limited to loss or damage to any other property.
- The Dimplex Guarantee is in addition to your statutory rights as a consumer and your statutory rights are not affected by this Dimplex Guarantee.

If you have any questions about what the Dimplex Guarantee covers and does not cover or how to claim under the Dimplex Guarantee, please contact us using the information on the back page.

### Contact details

Millbrook House, Grange Drive, Hedge End, Southampton, SO30 2DF



### Important

For electrical products sold within the European Community. At the end of the electrical products useful life it should not be disposed of with household waste. Please recycle where facilities exist. Check with a Local Authority or retailer for recycling advice in your country. Batteries should be disposed of or recycled in accordance with WEEE Directive 2012/19/EU. Packaging should be recycled where possible.

# Circuit Diagram - QM Series G.6

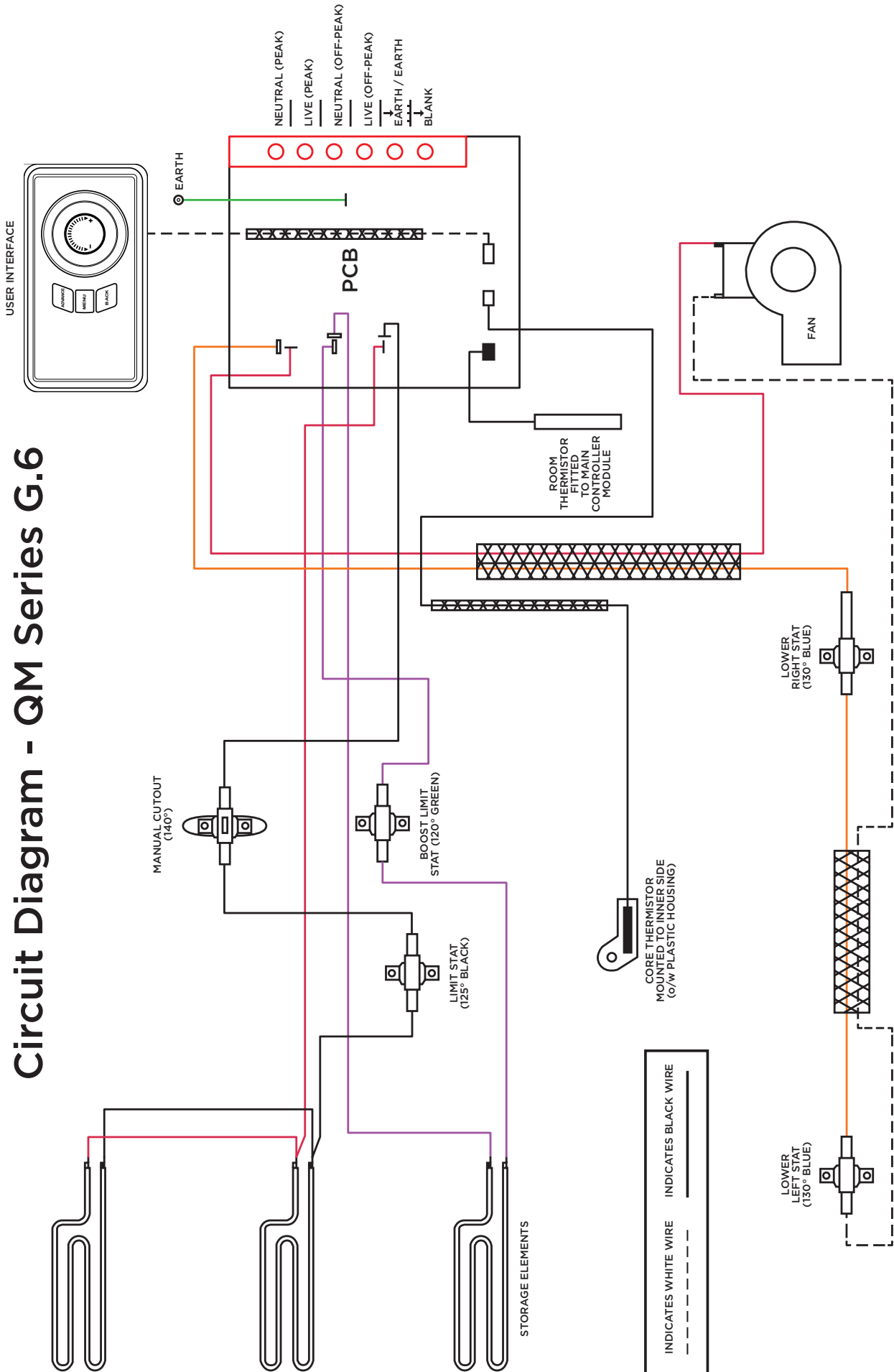

# Quantum G.6 Commissioning Checklist

Note: This represents the minimum software setup to commission this heater. Instructions here do not substitute or replace installation instruction requirements or warnings in the rest of this manual.

Model No.		Serial No.		Series		Install Date	
-----------	--	------------	--	--------	--	--------------	--

✓ each box to complete

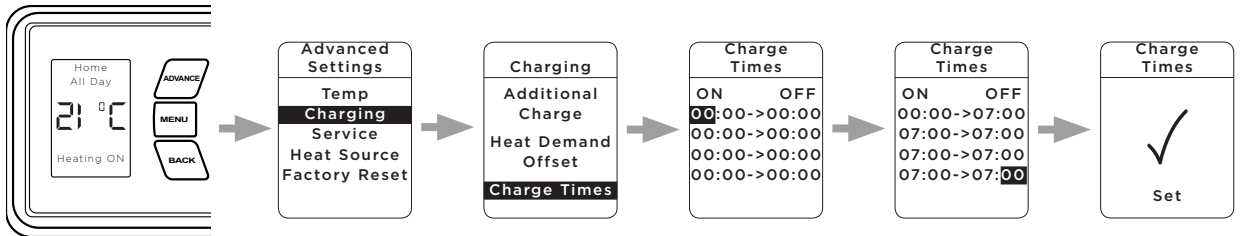
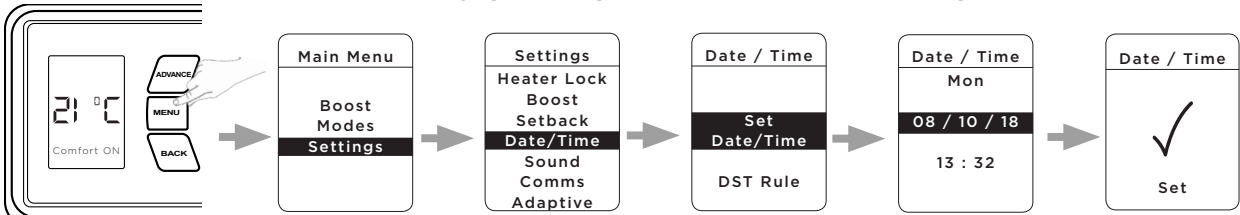
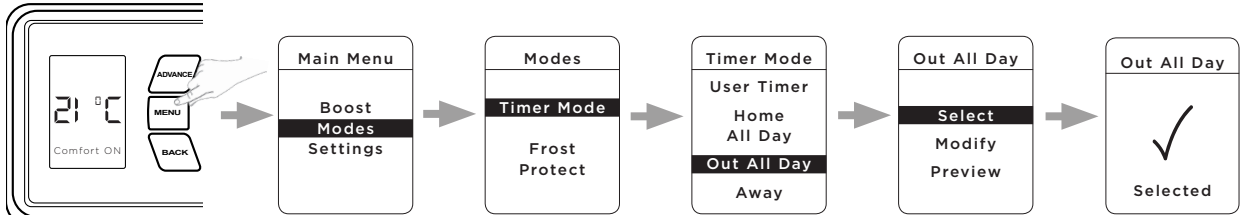
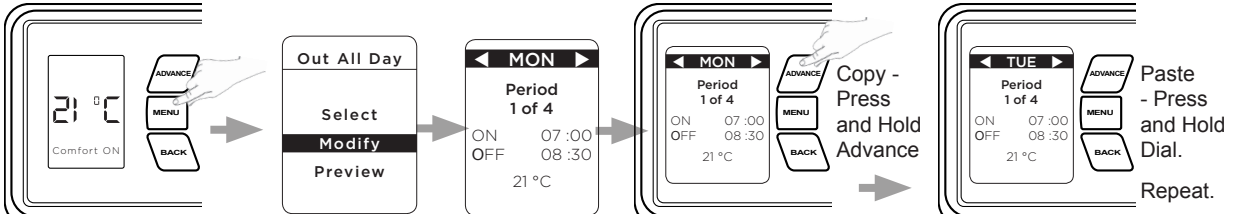
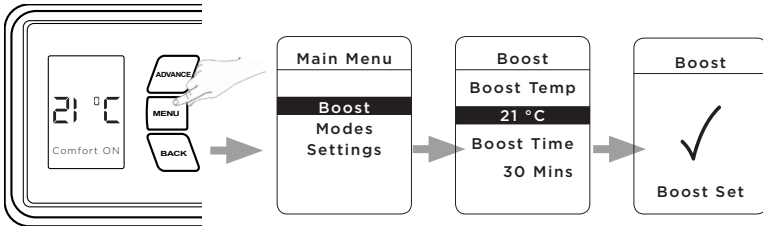
<p>1. Casing condition good, no dents or scratches.</p>	<p>2. 240V AC power available to both Peak and Off-Peak circuits.</p>	
<p>3. For Single Supply installations, set the heater Standalone Charge Times according to End User electricity tariff's Off-Peak rate times.</p> <p>A. Enter '<b>Advance Setup</b>': Press and hold <b>Advance/Menu</b> buttons at the same time for 5 seconds.</p> <p>B. Select '<b>Charging</b>' menu.</p> <p>C. Select '<b>Charge Times</b>' sub-menu</p> <p>D. Factory default times are 00:00 - 00:00. In this case the heater takes the charge whenever the Off-Peak supply available and the Run time been calculated.</p> <p>E. Set the Charge Times according to End User electricity tariff's Off-Peak rate times.</p> 		
<p>4. Check date and time is correct. Set Daylight savings time if appropriate (see wiring section)</p> 		
<p>5. Select Timer Mode (as per customer requirements).</p> 		
<p>6. Set Comfort Times (as per customer requirements).</p> 		
<p>7. Fan and Boost Test (NOTE - DISABLE BOOST WHEN TEST IS FINISHED).</p> 		



Customer Helpline: 0344 879 3588  
aftersales@dimplex.co.uk  
www.dimplex.co.uk

Glen Dimplex Heating & Ventilation  
Millbrook House, Grange Drive, Hedge End, Southampton, SO30 2DF

---

© Glen Dimplex. All rights reserved. Material contained in this publication may not be reproduced in whole or in part, without prior permission in writing of Glen Dimplex.

**CE** This product complies with the European Safety Standards EN60335-2-30 and the European Standard Electromagnetic Compatibility (EMC) EN55014, EN60555-2 and EN60555-3. These cover the essential requirements of EEC Directives 2006/95/EC and 2004/108/EC