

BRAND: Carson

STYLE: 5Lt Pendant

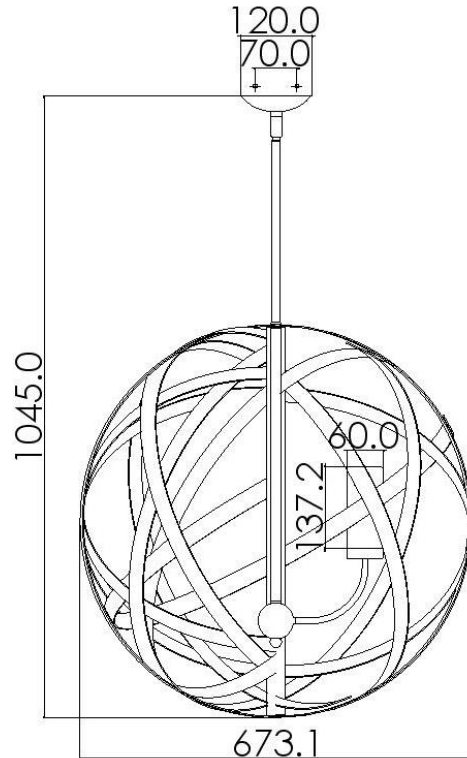

1. Item Code	HK/CARSON/5P	23. Maximum Drop	1506
2. Drawing No.	HK 29705VI Carson 5P	24. Adjustable?	Yes – Height Adjustable
3. Tested?	No	25. Shade/Glass Material	Clear Seedy Glass
4. Final Sign-Off Sample Done?	No	26. Shade Width (Mm)	60
5. Category	Outdoor	27. Shade Height (Mm)	137.2
6. Type	Pendant	28. Shade Depth (Mm)	60
7. Finish	Vintage Iron	29. Size Of Back-Plate/Ceiling Rose (Mm)	120 x 120
8. Ip Rating	IP44	30. Main Material	Steel
9. Class	I	31. Power Cable Colour	Brown
10. Voltage	240v	32. Power Cable Length (Mm)	3048
11. Wattage (1)	5 x Max 40w	33. Chain Length (Mm)	N/A
12. Wattage (2)	N/A	34. Rod Length (Mm)	2 x 304mm, 1 x 152mm
13. Lamp Holder Type (1)	5 X E14	35. Pir	No
14. Lamp Holder Type (2)	N/A	36. Switch Type And Location	N/A
15. No. Of Lamps	5	37. Connection Method	IP44 Terminal Block
16. Lamp Supplied	No	38. Plug Type	N/A
17. Dimmable?	Dependent On Lamp	39. Plug Colour	N/A
18. Lumen Output & Colour Temp	N/A	40. Product Weight (Kg)	5.9
19. Overall Width/Diameter (Mm)	673.1	41. Carton Dimensions (Mm)	TBC
20. Overall Height (Mm)	1045 (As Shown)	42. Carton Weight (Kg)	TBC
21. Overall Depth (Mm)	673.1	43. Notes 1	
22. Minimum Drop	TBC	44. Notes 2	