

Polycarbonate Chemical Resistance Table

Key:

- ▲ Resistant
- Limited resistance
- Not resistant

REAGENT	CONCENTRATION	RESISTANCE
Acetic Acid, aqueous	40	■
Acetic acid, aqueous	5	▲
Acetone		■
Ammonia, aqueous	10	■
Benzene		■
Beverages, alcoholic		▲
Bitumen		Not tested
Bleaching lye, aqueous		■
Boric Acid	10	▲
Butanol		■
Butter		●
Butyric acid		■
Calcium chloride, aqueous	10	▲
Carbon tetrachloride		■
Chlorine gas		●
Chlorine, aqueous solution		■
Chloroform		■
Citric acid, aqueous	10	▲
Coconut oil		▲
Diesel fuel		●
Edible fats		▲
Edible oils		▲
Ethanol	96	▲
Ethylene acetate		■
Ethylene ether		■
Formaldehyde, aqueous	30	▲
Formic acid, aqueous	40	●
Freon, liquid		▲
Frigen, liquid		▲
Fruit juices		▲
Fuel oil (heating)		●
Gas liquor		Not tested
Glycerine		▲
Glycol		▲
Glycantine, aqueous	40	Not tested
Hexane		▲
Hydrochloric acid, aqueous	2	■
Hydrofluoric acid, aqueous	40	▲
Hydrogen peroxide, aqueous	10	▲
Ink		▲
Iodine tincture, alcoholic		■

REAGENT	CONCENTRATION	RESISTANCE
Kerosene		■
Lactic acid, aqueous	10	▲
Lavender oil		Not tested
Linseed oil		Not tested
Machine oils		▲
Mercury		▲
Methanol		■
Methylene chloride		■
Milk		▲
Mineral oils		▲
Nitric acid, aqueous	2	▲
Oleic acid		▲
Ozone		▲
Paraffin oil		▲
Peppermint oil		Not tested
Perfumes		■
Petrol (gasoline)		●
Phenol, aqueous		■
Phosphoric acid, aqueous	10	■
Potassium hydroxide solution, aqueous	5	■
Potassium hydroxide solution, aqueous	50	■
Rose oil		●
Salt solution, household, aqueous	10	▲
Silicon oils		▲
Soap solution, aqueous		▲
Soda solution, aqueous	10	▲
Sodium hydroxide solution, aqueous	10	■
Sodium, aqueous	10	Not tested
Sulphur		▲
Sulphuric acid, aqueous	10	▲
Tallow		▲
Tar		▲
Tetrachloroethene		■
Toluene		■
Trichlorethane		■
Vaseline		▲
Water		▲
Water, hot (80°C)		●
Wax, melted		Not tested
Xylene		■

technical hotline +44 (0)1268 563720

ingress protected IP66 | wiring devices

13 Amp Socket Outlets

Standards and approvals

Socket outlets comply with BS 1363 Part 2: 1995.

All products allow compliance with BS 7671: 2008 when correctly installed.

Technical specification

Electrical

Voltage rating:
250V a.c.

Current rating:
13A per socket outlet

Terminal capacity:
Live, neutral & earth
3 x 2.5mm²
3 x 4mm²
2 x 6mm² (standard)

Physical

Ambient operating temperature:
0°C to +40°C

IP rating:
IP66

Max. installation altitude:
2000 metres



Description

A range of socket outlets specifically designed for use outdoors or in areas heavily exposed to dust and/or splashing water. Constructed from extremely robust polycarbonate, the range is sealed to IP66 against dust, water and is impact resistant and will completely protect virtually any 13 amp plug* including moulded plugs, allowing safe connection to any appliance.

*When in doubt, please use an MK 13A plug or Duraplug.

Boxes

Rear entry back boxes are supplied for surface mounted situations or flush mounting when used with Flush Mounting Bezels (K56502, 1 gang / K56503, 2 gang). These boxes must also be used

if cable or conduit enters the enclosure from the rear.

IP66 Protection

Each digit in the IP (Ingress Protection) rating denotes resistance to dust and water. The Masterseal Plus IP66 rating breakdown is as follows:

IP66		
Ingress protection	Solid protection: Dust tight No ingress of dust, complete protection against contact	Liquid Protection: Powerful jets of water against the enclosure from any direction shall have no harmful effects

Features

- IP66 protected to BS EN60529: 1992
- Ideal for gardens, workshops, industry, commercial, public areas, farm buildings, ponds, pools etc
- Easy to install: fixed gasket, captive backed out terminal screws, clearly marked top access angled terminals, push fit knockouts and conduit entries, rear drill holes
- Patented gel seal provides durable water and dust tight seal for improved protection
- Sealed when in use with virtually any standard 13 AMP plug, including those with moulded plug tops
- Improved catch eases opening and closing during use
- Manufactured from recycled polycarbonate for impact protection and environmental protection
- 3 pin operated safety shutter on socket outlets
- 3mm minimum switch contact gap
- Additional electrical safety from neutral 'make first, break last' feature
- Moulded 'on' indicator flash on switches will not rub off
- Printed terminal markings on grey rear mouldings for clearer identification
- Double pole switching
- Switch contacts with silver contacts on both surface for good continuity
- Products are available in grey, black and white

Dimensions (mm)

1 gang / 2 gang with fixing dimensions

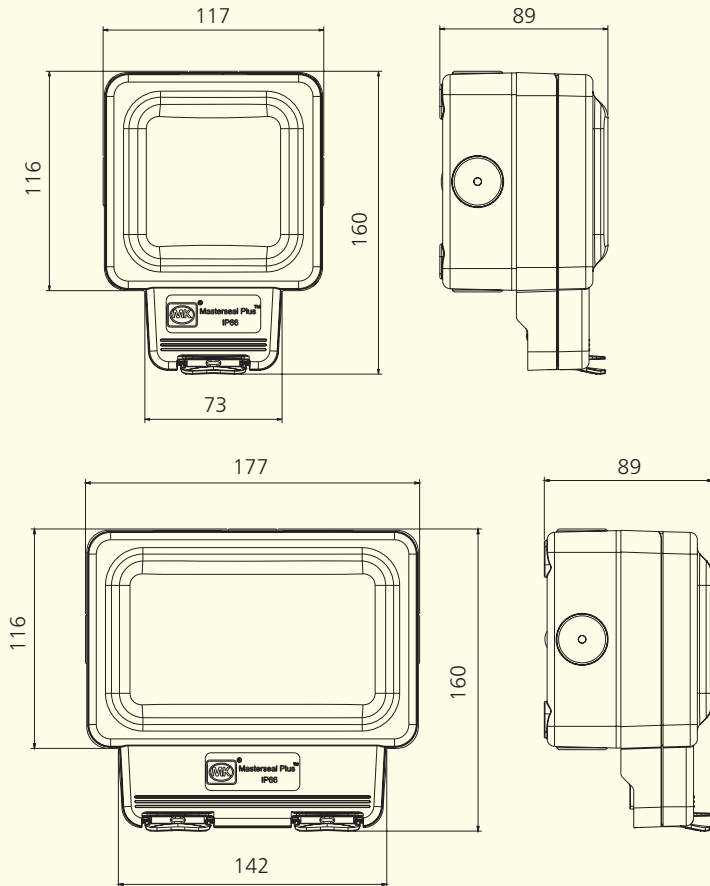

Flush Mounting Bezels

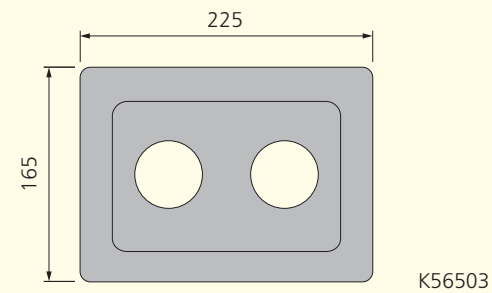
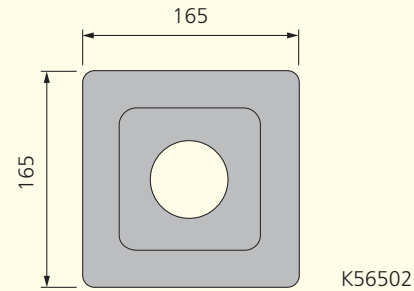

Flush Mounting Bezel Cut-outs

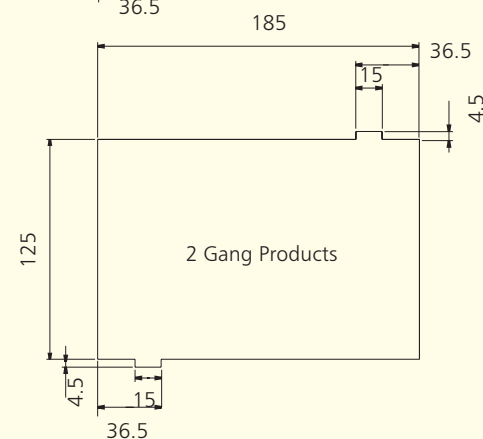
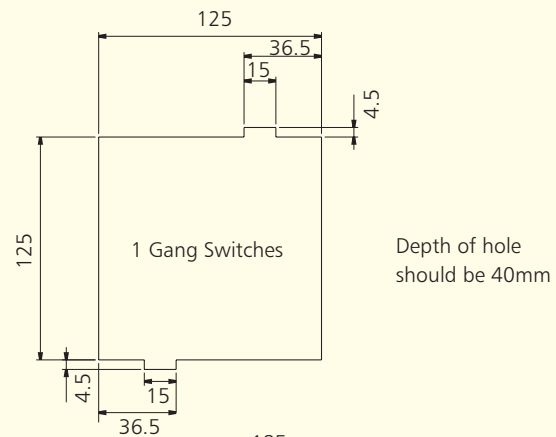

Timer Socket Outlet

Standards and approvals

Socket outlet complies with BS 1363 Part 2: 1995.

Enclosure conforms to BS EN 60529 IP66

Timer module complies with IEC 60730-1
IEC 60730-2-7, EN 55014 -1: 2000, EN 55022,
EN 61000-3-2, EN 61000-4-2, EN 61000-4-4,
EN 61000-4-5, EN 61000-4-6, EN 61000-4-11



Technical specification

Electrical

Supply Voltage 230V a.c.
Supply frequency 50Hz
Current rating for socket outlet (RESISTIVE) 13A

Terminal capacity

Supply Line, Neutral and Earth 3 x 2.5mm²
3 x 4 mm²
2 x 6 mm²

Physical

Ambient operating temperature range: 0°C to +40°C
IP rating: IP66
Max. installation altitude: 2000 metres

Features

- Single 13A rated socket outlet switched via the Single Pole timer module
- Weekly Electronic Timer
- 24 hour clock
- Multi-function Liquid Crystal Display (LCD)
- 6 ON/OFF programmes per day
- Individual day selection as well as 4 block day selections
- Supplied with a LOOP terminal in the back box, which has 5 entries for cables
- Override button to switch the load ON/OFF directly, bypassing the timer
- Patented gel seal provides durable water and dust tight seal for improved protection
- Sealed when in use with virtually any standard 13 AMP plug, including those with moulded plug tops
- Improved catch eases opening and closing during use
- Manufactured from recycled polycarbonate for impact protection and environmental protection
- 3 pin operated safety shutter on socket outlets
- Products are available in grey, black and white

Description

This socket outlet, switched by a single pole timer module is specifically designed for use outdoors or in areas heavily exposed to dust and/or splashing water. Constructed from extremely robust polycarbonate, the product is sealed to IP66 against dust and water, and is impact resistant. The product ensures a very high degree of protection for virtually any 13A plug* to BS 1363, allowing safe connection to electrical appliances, which can be switched on and off at pre-determined times.

Timer module

The product employs an electronic timer module, which switches the Supply Line to the socket outlet, via a single pole relay. 6 ON/OFF cycles per day can be programmed via the buttons on the face of the timer module. Days in the week can be set individually or set to repeat in 4 separate blocks as follows:

1. Monday to Friday
2. Saturday and Sunday
3. Monday to Saturday
4. Monday to Sunday

An Override button is available to switch the load ON/OFF directly, bypassing the timer.

Dimensions (mm)

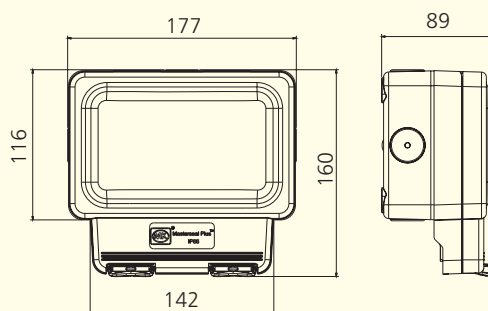

Boxes

Rear entry back box is supplied for surface mounted situations or flush mounting when used with Flush Mounting Bezel (K56503). These boxes must also be used if cable or conduit enters the enclosure from the rear.

IP66 Protection

Each digit in the IP (Ingress Protection) rating denotes resistance to dust and water. The Masterseal Plus IP66 rating breakdown is as follows:

* When in doubt, please use an MK 13A plug

IP66		
Ingress protection	Solid protection: Dust tight No ingress of dust, complete protection against contact	Liquid Protection: Powerful jets of water against the enclosure from any direction shall have no harmful effects

Flush Mounting Bezel

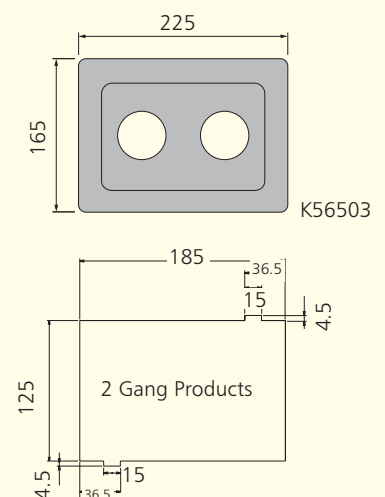

Sentrysocket

Compliance with EC Directives, Standards and approvals

All Sentrysockets comply with the following EC Directives and are CE marked:

Low Voltage Directive Electromagnetic Compatibility Directive (89/336/EEC)

Sentrysocket RCD Single Sockets also comply with the requirements of the following standards:

BS 7288: 1990

BS EN 50082-1: 1992

Sentrysocket RCD Double Sockets also comply with the requirements of the following standards:

BS 7288: 1990

BS EN 61543: 1996



Technical specification

Electrical

Rated Voltage:
240V a.c.

Current rating:
13A resistive

Rated tripping current:
30mA

Terminal capacity:
3 x 4mm²

Physical

Ambient operating temperature:
0°C to +40°C

IP rating:
IP66

Max. installation altitude:
2000 metres

Features

- Suitable for most residential, commercial and light industrial applications
- Active and passive control circuit applications
- Comply fully with current Wiring Regulations if installed correctly
- Double pole switching
- Flexible and versatile in use
- Ideal for use with equipment subject to wet weather or high humidity
- They are a.c. and pulsating d.c. fault current sensitive

Description

Sentrysocket provides a high level of protection for portable equipment when used in damp environments or outdoors.

Active control circuits

Incorporate a 'Re-set' mechanism and are mains failure sensitive, ie they will function under all the normal conditions expected of an RCD, but will also trip in the event of a power cut or a sudden, dramatic reduction in mains voltage. This makes them ideal for use where it would be hazardous for equipment to suddenly energise after return of mains power, such as use with rotating machinery and heat developing apparatus.

Passive control circuit

Incorporates a 'Stay-set' mechanism and is mains failure proof, ie it will function under all the normal conditions expected of an RCD and will not trip in the event of a power cut. This makes it suitable for use with freezers or in inaccessible or unmanned locations.

Dimensions (mm)

Single and double Sentrysockets are identical in size and shape. The following dimensions apply

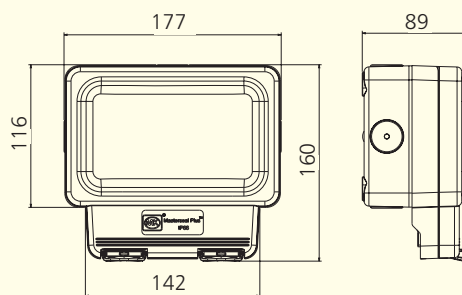

Masterseal Plus Sentrysocket is suitable for surface mounting only.

Fixing Dimensions

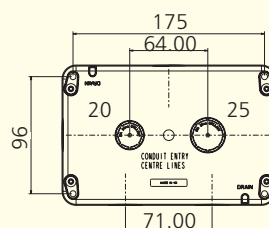

16A 2P+E Socket Outlet (Non UK)

Standards and approvals

Complies with IEC 60884-1: 2006

Technical specification

Electrical

Voltage rating:
250V a.c.

Current rating:
16A

Terminal capacity:
Live, neutral & earth
4 x 1.5mm²
2 x 2.5mm²
1 x 4mm²

Physical

Ambient operating temperature:
0°C to +40°C
(not to exceed an average of more than 25°C in any
24 hour period)

IP rating:
IP66

Max. installation altitude:
2000 metres



Masterseal 16A 2P + E German socket outlet is suitable for surface mounting only.

Dimensions (mm)

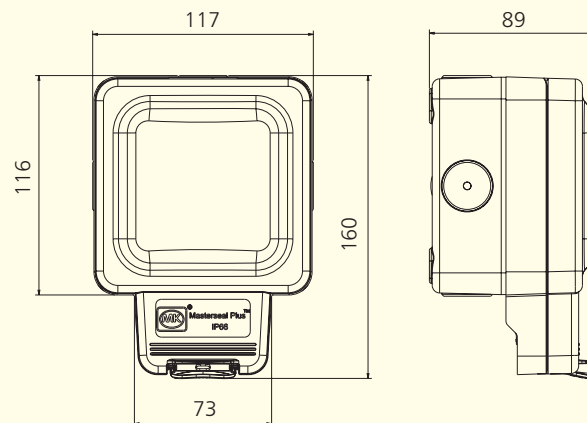

IP66		
Ingress protection	Solid protection: Dust tight No ingress of dust, complete protection against contact	Liquid Protection: Powerful jets of water against the enclosure from any direction shall have no harmful effects

Features

- IP66 protected to BS EN60529: 1992
- Patented gel seal provides durable water and dust tight seal for improved protection
- Sealed when in use with virtually any plug with a right-angled cable exit, including those with moulded plug tops
- Improved catch eases opening and closing during use
- Manufactured from recycled polycarbonate for impact protection and environmental protection
- Products are available in grey, black and white

Fixing dimensions

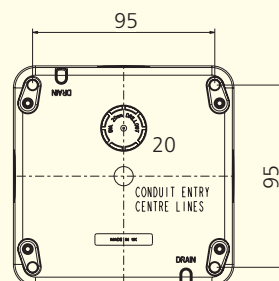

Connection Units

Standards and approvals

All Masterseal Plus Connection Units comply with BS 1363 Part 4: 1995. All units are fitted with a 13A fuse link to BS 1362.

Technical specification

Electrical

Voltage rating:
250V a.c.

Current rating:
Connection units – 13 amp

Terminal capacity:

Supply terminal: 2 x 6mm² stranded
3 x 4mm²
3 x 2.5mm²
3 x 1.5mm²

Load terminals: 1 x 1.5mm²

Physical

Ambient operating temperature:
–5°C to +40°C (not to exceed an average of more than 25°C in any 24 hour period)

IP rating:
IP66

Max. installation altitude:
2000 metres

Features

- IP66 protected to BS EN60529: 1992
- Ideal for gardens, workshops, industry, commercial, public areas, farm buildings, ponds, pools etc
- Easy to install: fixed gasket, captive backed out terminal screws, clearly marked top access angled terminals, push fit knockouts and conduit entries, rear drill holes
- Patented gel seal provides durable water and dust tight seal for improved protection
- Improved catch eases opening and closing during use
- Manufactured from recycled polycarbonate for impact protection and environmental protection
- Screw fitted fuse carrier
- Fuse carrier lockable in open position
- Captive fuse carrier
- 3mm minimum switch contact gap
- Double pole switching
- Moulded 'on' indicator flash on switches will not rub off



Description

Masterseal Plus connection units are specifically designed for use outdoors or in areas heavily exposed to dust and/or splashing water. Constructed from extremely robust polycarbonate, the range is sealed to IP66 against dust, water and is impact resistant and will completely protect and provide a safe connection to any appliance.

IP66 Protection

Each digit in the IP (Ingress Protection code) rating denotes resistance to dust and water. The Masterseal IP66 rating breakdown as is follows:

Impact Resistance

IP66		
Ingress protection	Solid protection: Dust tight No ingress of dust, complete protection against contact	Liquid Protection: Powerful jets of water against the enclosure from any direction shall have no harmful effects

Dimensions (mm)

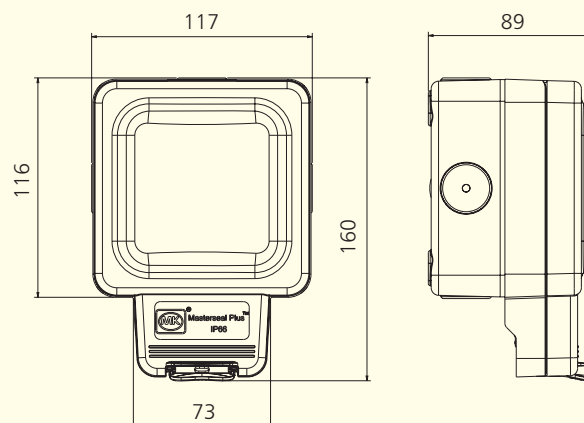

Installation

Masterseal Plus connection units can be wall or bench mounted. Do not use on a trailing lead.

All Masterseal Plus products have an impact resistance equivalent to a 500g object falling from a height of 40cm.

Boxes

Rear entry back boxes are supplied for 'tamper proof' surface mounted situations or flush mounting when used with Flush Mounting Bezels (K56502). These boxes must also be used if cable or conduit enters the enclosure from the rear.

technical hotline +44 (0)1268 563720

ingress protected IP66 | wiring devices

Switches

Standards and approvals

Switches and enclosures comply with BS EN 60669-1: 1999 and are IP66 for BS EN 60529: 1992.

20A Switch modules comply with BS EN 60669-1: 1999.

10A Switch modules comply with BS EN 60669-1: 1999.

All products comply with or allow compliance with BS 7671: 2008.

Technical specification

Electrical

Voltage rating:
250V a.c., 50 Hz

Current rating:
10 or 20 amps – no derating when used on fluorescent or inductive loads.

Load type:
No restriction

Physical

Ambient operating temperature:
0°C to +40°C

IP rating:
IP66
(Grid Plus enclosures are IP56)

Max. installation altitude:
2000 metres

Features

- IP66 protected to BS EN60529: 1992
- Ideal for gardens, workshops, industry, commercial, public areas, farm buildings, ponds, pools etc
- Easy to install: fixed gasket, captive backed out terminal screws, clearly marked top access angled terminals, push fit knockouts and conduit entries, rear drill holes
- Improved catch eases opening and closing during use
- Manufactured from recycled polycarbonate for impact protection and environmental protection
- Large, easy to use rocker switches
- Wide range of switch modules and accessories make Masterseal versatile
- Switch modules snap into position



Description

A range of switches and enclosures specifically designed for use outdoors or in areas heavily exposed to dust and/or splashing water. Constructed from extremely robust polycarbonate, the range is sealed to IP66 against dust, water and is impact resistant. Masterseal is easy to install and the large rocker switches and clip in modules make it easy to use, even when wearing heavy gloves.

IP66 Protection*

Each digit in the IP (Ingress Protection) rating denotes resistance to dust and water. The Masterseal IP66 rating breakdown is as follows:

IP66		
Ingress protection	Solid protection: Dust tight No ingress of dust, complete protection against contact	Liquid Protection: Powerful jets of water against the enclosure from any direction shall have no harmful effects

Dimensions (mm)

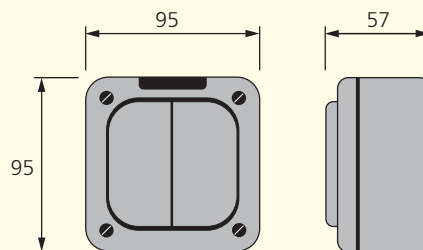

Fixing dimensions

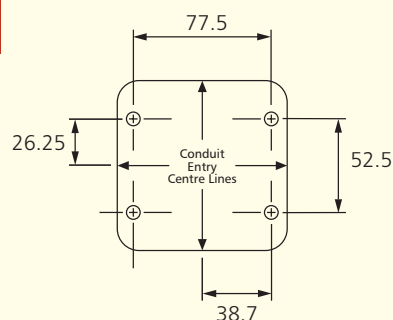

Boxes

Rear entry back boxes are supplied for surface mounted situations or flush mounting when used with Flush Mounting Bezels (56502). These boxes must also be used if cable or conduit enters the enclosure from the rear.

* Grid Plus enclosures are IP56

Flush Mounting Bezel

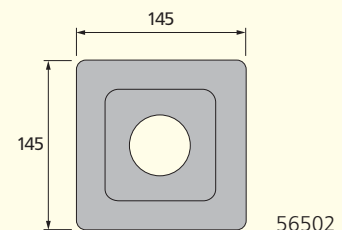

Flush Mounting Frame

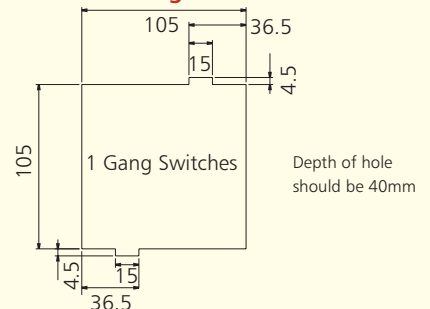

Grid Plus Enclosures



Customer Configurable Grid – K56414

- 1 Up to two wiring device modules may be selected from the MK Grid Plus modular range and fitted to the configurable grid enclosure.
- 2 If a TV outlet is to be fitted in combination with a mains voltage device, then it is essential that the cabling and modules are isolated from each other.
- 3 Grid modules are assembled into the front face of the front plate and clip firmly into position.
- 4 Two bezel mouldings are supplied. Select the appropriate bezel depending on whether one or two modules are fitted, locate in position and secure with the two screws provided as shown in Figure 1.

Figure 1

Fixing dimensions

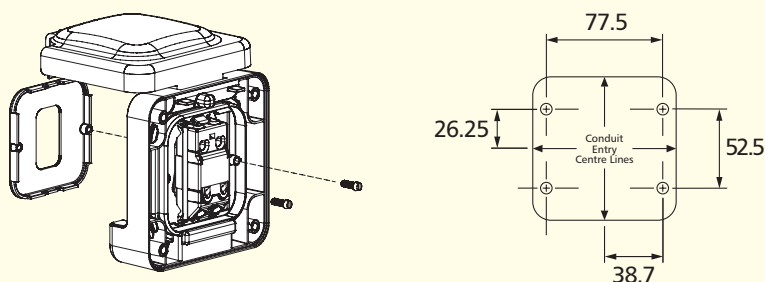

technical hotline +44 (0)1268 563720

ingress protected IP66 | wiring devices

Euro Enclosure and Telephone and Data Modules

Standards and approvals

Telephone sockets K5820 and K5821 comply with the following:
BS 6312: 2.2, OFTEL Approval NS/G/23/L/100005.

K5844/K5845/K5845s comply with:
ISO/IEC 11801, EN 50173, TIA 568, and EN 41003.

K5887 complies with FCC68 and EN 41003.



Technical specification

Installation tools required IDC Connectors (telephone & RJ45 outlets)

Electrical

Cable types:
Telephone: CW1311, CW1293, CW1308, CW1316

No. of cables per termination:
Telephone: 2
RJ11/12: 1
RJ45: 1

Termination type: IDC

Physical

Temperature range:
Ambient air 0°C to +40°C

IP rating: IP66 (enclosure)

Max. installation altitude: 2000 metres

Description

A range of Euro telephone, data and blank modules and weatherproof enclosure. Enclosure accommodates 2 modules providing care is used to ensure that the cables are correctly routed through the outlet.

Features

- IP66 data and telecoms protection
- Meet all relevant BS, OFTEL and cabling standards
- Interchangeable modules clip into enclosure
- Can be specified for all applications

Installation (Telephone socket modules)

Product performance, systems compatibility

Master Sockets: For use as the first socket outlet on a direct exchange. They contain the required surge protector (for line protection against electrical surges) and ringing capacitor.

Secondary Sockets: for use as extension sockets when connected on the same line as a Master Socket.

MODULE DIMENSIONS (mm)

25 x 50

Installation tools required IDC Connectors (telephone & RJ45 outlets)

MK insertion tool List No. 400NAT.
Wire pull-out force: 10.5 Newtons when installed correctly.

Wiring regulation restrictions

Domestic Installations: The total REN (Ring Equivalent Number) value of all telephone equipment connected on a line must not exceed 4.

FOR EURO MODULE WIRING DIAGRAMS, PLEASE REFER TO LOGIC PLUS TECHNICAL SECTION, Pages 446-448

IP66		
Ingress protection	Solid protection: Dust tight No ingress of dust, complete protection against contact	Liquid Protection: Powerful jets of water against the enclosure from any direction shall have no harmful effects

Installation

Notes:

1. The enclosure is made from polycarbonate which is a highly durable material, and ideal for most environments. However, if installing in areas where creosote, some chemicals, synthetic oils and harsh cleaners are used, seek advice from MK Technical Sales Service Department.

2. The enclosure must be mounted on a flat, vertical surface that is free from grease, dirt and loose material.

3. If the conduit cable entry is from the top or sides the lower drain hole in the mounting box must be drilled out using a 5mm diameter drill bit. This will allow any condensation formed in the conduit system to drain out of the unit.

Note: opening the drain hole will reduce the IP rating; therefore ensure that jetted water is not directed at the unit.

4. The drain hole should not be drilled out if the enclosure is to be installed in an excessively dusty environment. If the drain hole is not drilled out, only the bottom cable entry must be used.

5. If conduit is used for bottom cable entry, a 5 mm diameter drain hole needs to be drilled in the lowest point of the conduit run.

6. If wiring directly to the enclosure without conduit and the installation is outdoors, ensure that a cable specified for outside use is used.

7. Please note; the colour codes used for rigid cabling in the UK since April 2004 and in all other areas of the EU, are as follows;

BROWN = terminals marked 'L'

BLUE = terminals marked 'N'

GREEN / YELLOW = terminals marked .

The colour codes used prior to April 2004 were;

RED = terminals marked 'L'

BLACK = terminals marked 'N'

GREEN / YELLOW = terminals marked .

8. PVC Cable Entry (see Service Items) must only be used at the bottom cable entry of the enclosure.

Instructions:

CAUTION

Do not allow paint or wood preservative to come into contact with the product. The product can be safely mounted on painted surfaces or surfaces treated with wood preservative when the paint or wood preservative is completely dry.

1. Read the safety instructions.
2. Mark the position of the fixing holes for the mounting box.
3. Drill holes and fit wall plugs suitable for a No. 8 wood screw.
4. Prior to fitting the mounting box to the wall, drill out the drain hole if required (see Installation Note 3). File out the complete drain hole profile. Take care not to damage the small internal wall.
5. Carefully remove the cable entry blanks, or drill out the rear cable entry, as required and fit conduit entry (see Service Items).
6. Secure the mounting box to wall with four No. 8 wood screws. Position drain hole at bottom left hand corner.
7. Align and install conduit or cable entry as required.
8. Seal the conduit and conduit entry with a non setting conduit sealant such as Egaweld™ Plus. Refer to Figure 4.

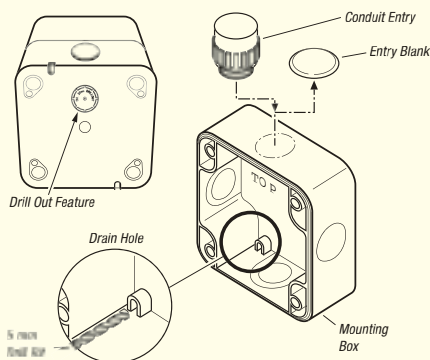

9. For instructions on how to wire the front plate of telephone and data products see the instruction leaflets supplied with the appropriate module.

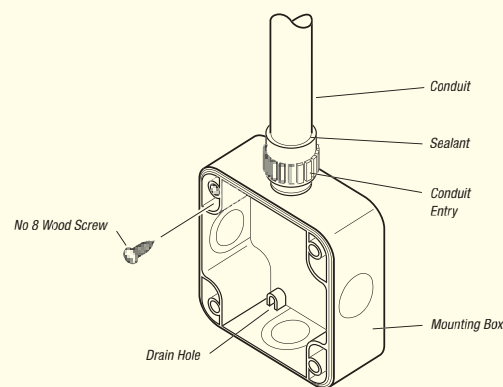

Figure 4

10. Before wiring and fitting the front plate, position the seal on the front plate. Ensure the holes are aligned and seal is aligned with the ribs on the mounting box and the cables are threaded through the seal and screws are fully tightened.

11. Wire and fit the front plate. Ensure the seal is correctly located and the cables are not trapped or pinched.

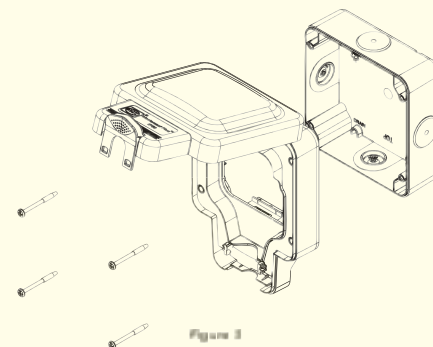

Figure 5

WHEN INSTALLING CONNECTION UNITS USING THE FRONT FLEXIBLE

CABLE CLAMP

1. Strip back the outer sheath on the appliance flexible LOAD cable and trim wires to 55mm in length. Do not trim the insulation on the three individual cables for the moment.
 2. When using cables of 10mm or more in diameter, it is necessary to prestress the cable clamp before attempting to load the cable.
 3. To pre-stress the clamp insert a flat bladed screwdriver into the cord grip as shown in fig. 6a and flex the clamping jaw open until it touches the grey base moulding fig. 6b. Then remove the screwdriver.
- IMPORTANT: The clamp must not be re-used for cables below 6mm diameter after pre-stressing.
4. Cables below 10mm diameter do not need the cable clamp pre-stressed and the installation from this point is the same for all products.
 5. To assist pushing the load cable through the front of the product, ease the clamping jaw pressure by holding the product securely in one hand and pushing the tab firmly with your thumb in the direction shown in fig. 7a.
 6. Continue pushing the cable through the clamp until the outer sheath reaches the cable stops. See fig. 7b. The jaws must clamp on the outer sheath.
 7. Carefully strip back the insulation on all three cables to expose 10mm of the conductor.
 8. Ensure all conductors are connected to the appropriate terminals.

Terminal screws must be securely tightened. Pull on each cable to ensure that the terminal screw has securely fixed the conductor.

Notes:

Testing:

Test the completed installation in accordance with the latest edition of the IEE wiring regulations (BS 7671).

Service and Maintenance:

CLEANING

1. The exterior of the product must only be cleaned with a solution of mild detergent (e.g. washing up liquid) and warm water.

CABLE SEAL CAPSULE REPLACEMENT

1. Note the orientation of the cable seal capsules in the lid and front plate.
2. Carefully remove the two cable seal capsules with a flat bladed screwdriver and discard. Refer to Figure 8.
3. Install the new cable seal capsules orientated as noted on removal.

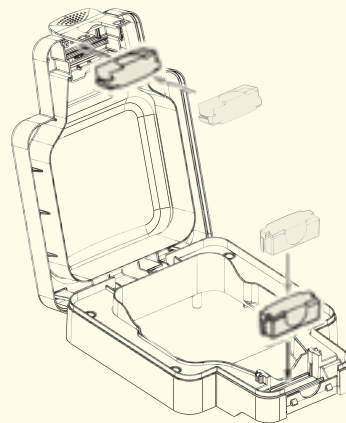

Figure 8

Pre-stressing the front cable clamp for cables greater than 10mm in diameter

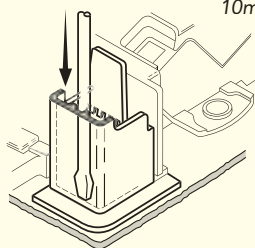

Figure 6a

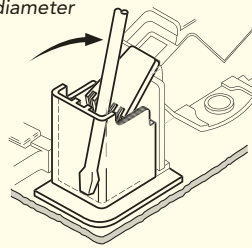

Figure 6b

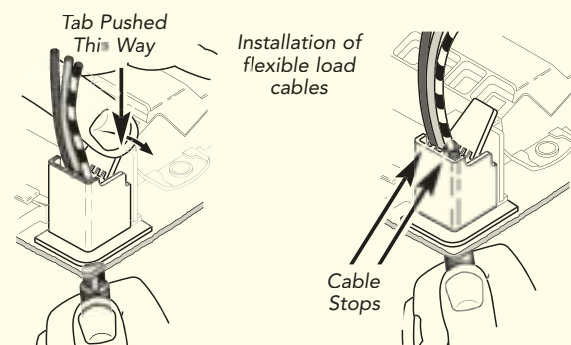

Figure 7a

Figure 7b