

**TRITON**

## *T90xr pumped electric shower*



## **Installation and operating instructions**

INSTALLERS PLEASE NOTE THESE INSTRUCTIONS ARE TO BE LEFT WITH THE USER

<b>CONTENTS</b>	<b>Page</b>
Important safety information	1
Introduction	2
Specifications	2
Advice to users	2
Main components	3
Electrical requirements	4
Water requirements	6
Siting of the shower	7
Fitting the shower to the wall	9
Plumbing connections	11
Electrical connections	12
Commissioning	13
Operating the shower	16
Operating functions	18
Instructions for installers and service engineers only	19
Spare parts	20
Fault finding	21 - 22
Guarantee, service policy, etc.	rear cover

To check the product suitability for commercial and multiple installations, please contact Triton's specification advisory service before installation.

Telephone: 0870 067 3767

Facsimile: 0870 067 3334

E mail: [technical@tritonshowers.co.uk](mailto:technical@tritonshowers.co.uk)

**PLEASE READ THIS IMPORTANT SAFETY INFORMATION**

- ◆ Products manufactured by Triton are safe and without risk provided they are installed, used and maintained in good working order in accordance with our instructions and recommendations.
- ◆ DO NOT connect this shower directly to the mains water supply.
- ◆ **WARNING: DO NOT operate shower if frozen, or suspected of being frozen. It must thaw out before using.**
- ◆ DO NOT operate the unit if the shower head or spray hose becomes damaged.
- ◆ DO NOT restrict flow out of shower by placing shower head in direct contact with your body.
- ◆ DO NOT operate the shower if water ceases to flow during use or if water has entered inside the unit because of an incorrectly fitted cover.
- ◆ **WARNING: If restarting the shower immediately after stopping, be aware that a slug of hot water will be expelled for the first few seconds.**

**1 GENERAL**

- 1.1** Isolate the electrical and water supplies before removing the cover.
- 1.2** Read all of these instructions and retain them for later use.
- 1.3** DO NOT take risks with plumbing or electrical equipment.
- 1.4** Isolate electrical and water supplies BEFORE proceeding with the installation.
- 1.5** The unit must be mounted onto the finished wall surface (on top of the tiles). DO NOT tile up to unit after fixing to wall.
- 1.6** Contact Customer Service (*see back page*), if any of the following occur:
  - a)** If it is intended to operate the shower at pressures above the maximum or below the minimum stated.
  - b)** If the unit shows a distinct change in performance.
  - c)** If the shower is frozen.
- 1.7** If it is intended to operate the shower in areas of hard water (above 200 ppm temporary hardness), a scale inhibitor may have to be fitted. For advice on the Triton Scale Inhibitor, contact Triton Customer Service.
- 1.8** The shower head must be cleaned regularly with descalent to remove scale and debris, otherwise restrictions to the flow on the outlet of the unit will result in higher temperatures and could also cause the Pressure Relief Device in the unit to operate.
- 1.9** This product is not suitable for mounting into steam rooms or steam cubicles.

**2 PLUMBING**

- 2.1** The plumbing installation must comply with Water Regulations, Building Regulations or any particular regulations as specified by Local Water Company or Water Undertakers and should be in accordance with BS 6700.
- 2.2** The supply pipe must be flushed to clear debris before connecting to the shower unit.
- 2.3** DO NOT solder pipes or fittings within 300 mm

of the shower unit, as heat can transfer along the pipework and damage components.

- 2.4** DO NOT fit any form of outlet flow control as the outlet acts as a vent for the heater can.
- 2.5** DO NOT use excessive force when making connections to the flexible hose or shower head, finger tight is sufficient.
- 2.6** All plumbing connections MUST be completed BEFORE making the electrical connections.

**3 ELECTRICAL**

- 3.1** The installation must comply with BS 7671 'Requirements for electrical installations' (IEE wiring regulations), Building Regulations or any particular regulations as specified by the local Electrical Supply Company.
- 3.2** This appliance MUST be earthed.
- 3.3** In accordance with 'The Plugs and Sockets etc. (Safety) Regulations 1994', this appliance is intended to be permanently connected to the fixed wiring of the electrical mains system.
- 3.4** Make sure all electrical connections are tight to prevent overheating.
- 3.5** Fuses do not give personal protection against electric shock.
- 3.6** To enhance electrical safety a 30mA residual current device (RCD) should be installed in all UK electric and pumped shower circuits. This may be part of the consumer unit or a separate unit.
- 3.7** Switch off immediately at isolating switch if water ceases to flow during use.
- 3.8** Other electrical equipment i.e. extractor fans, pumps must not be connected to the circuits within the unit.

**3.9** Switch off at isolating switch when not in use. This is a safety procedure recommended with all electrical appliances.

- 3.10** As with all electrical appliances it is recommended to have the shower and installation checked at least every two years by a competent electrician to make sure there is no deterioration due to age and usage.

### INTRODUCTION

This book contains all the necessary fitting and operating instructions for your Triton pumped electric shower. Take time to read this book thoroughly and familiarise yourself with all instructions before installing. Please keep it for future reference.

The shower installation must be carried out in the sequence of this instruction book.

Do not attempt any electrical or plumbing work necessary to install this product unless you have good practical experience and adequate understanding of the IEE regulations and water regulations

Care taken during the installation will provide a long, trouble-free life from your shower.

### SPECIFICATIONS

#### Electrical

Nominal power rating at 240V	Nominal power rating at 230V
8.5kW – (40A MCB rating)	7.9kW – (40A MCB rating)
9.5kW – (40A MCB rating)	8.7kW – (40A MCB rating)

Pump motor rating 120 Watt – single phase.

This product is rated at: 15 minutes on / 45 minutes off.
--

#### Water

Inlet connection – 15mm diameter

Outlet connection – ½" BSP male thread

#### Entry Points

Water – top, bottom, back

Cable – top, bottom, back

#### Materials

Backplate, cover, controls, showerhead – ABS

Sprayplate – Acetal

Elements – Minerally insulated corrosion resistant metal sheathing

#### Dimensions (mm)

Height – 268, Width – 330, Depth – 104

#### Standards and Approvals

Splashproof rating IPX4

Complies with the requirements of current British and European safety standards for household and similar electrical appliances.

Complies with requirements of the British Electrotechnical Approvals Board (BEAB).

Meets with Compliance with European Community Directives (CE).

### ADVICE TO USERS

The following points will help you understand how the shower operates:

- a.** The electric heating elements operate at a constant rate at your chosen power setting. It is the rate of the water passing through the heater unit which determines the shower temperature at any given setting. (The slower the flow the hotter the water becomes, and the faster the flow the cooler the water.)
- b.** During winter, mains water supply will be cooler than in summer. Therefore, the temperature of the shower will vary between seasons on any one setting of the temperature control, e.g. if you have chosen setting number 6 as your preferred shower temperature in the summer, you will have to increase that number during winter by adjusting the temperature control clockwise (which in effect slows the water flow).
- c.** If for any reason there is a sudden rise in water temperature, the unit has thermal cut-out devices built-in (see items 3 and 4 under 'Fault Finding').
- d.** Switch off immediately at the isolating switch if water ceases to flow. Press the Start/Stop button and contact Customer Service for advice.

**If ever the water becomes too hot and you cannot obtain cooler water, first check that the sprayplate in the showerhead has not become blocked.**

DO NOT place items such as soap or shampoo bottles on top of the unit. Liquid could seep through the joint between the cover and backplate, and possibly damage the sealing rubber.

Replacement parts can be ordered from Customer Service. See 'spare parts' for details and part numbers.

**MAIN COMPONENTS**

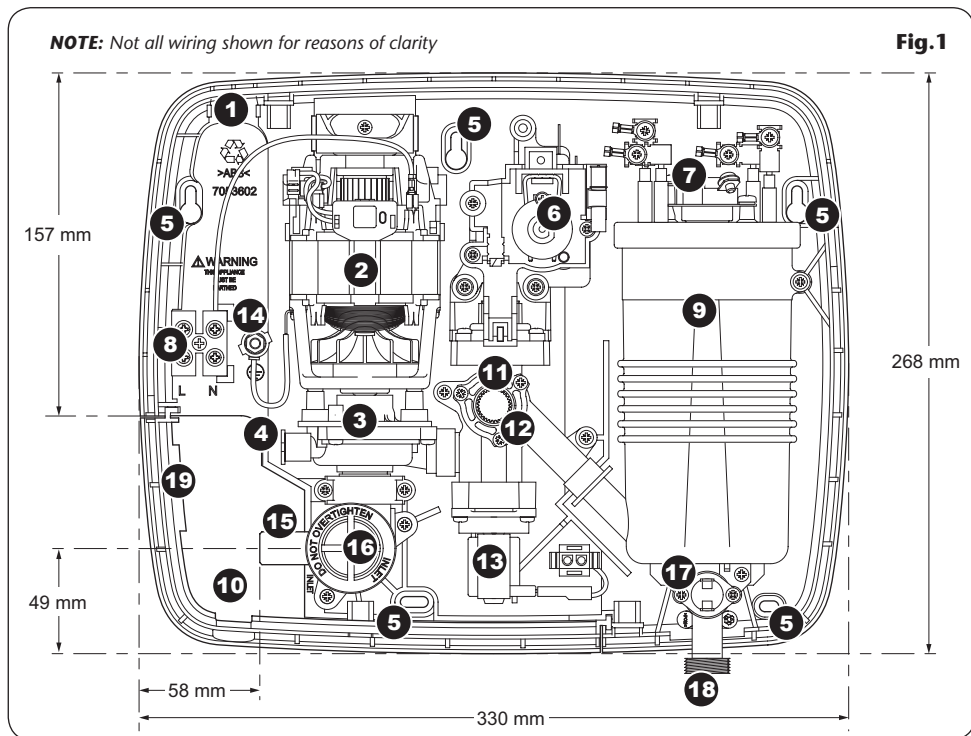

**Inside unit (fig.1)**

- 1. Top pipe / cable entry
- 2. Motor assembly
- 3. Pump assembly
- 4. Bleed screw
- 5. Wall screw fixing
- 6. Power selector assembly
- 7. Thermal cut-out (main)
- 8. Terminal block
- 9. Can and element assembly
- 10. Area for bottom and back pipe/cable entry
- 11. Pressure switch
- 12. Temperature valve
- 13. Solenoid valve
- 14. Earth connection
- 15. Inlet pipe

- 16. Filter
- 17. Thermal cut-out (outlet)
- 18. Outlet pipe
- 19. Trimplate

**Other items**

- Screw fixing kit
- Instructions, guarantee, etc.

**IMPORTANT:** When first installed the unit will be empty. It is essential the unit should contain water before the elements are switched on. It is vital that the commissioning procedure is followed. Failure to carry out this operation will result in damage to the unit and will invalidate the guarantee.

## ELECTRICAL REQUIREMENTS

**WARNING!**  
**THIS APPLIANCE MUST BE EARTHED**

The installation, supply cable and circuit protection must conform with BS 7671 (IEE wiring regulations) and be sufficient for the amperage required.

The following notes are for guidance only:

- 1 The shower must only be connected to a 230-240V ac supply. If you are installing a shower with a kilowatt rating above 9kW, it is advisable to contact the local electricity supply company.
- 1.1 The electrical rating of the shower is shown on the rating label (**Fig.3**) within the unit.



**Fig.2**

**Fig.3** Schematic of installation circuit

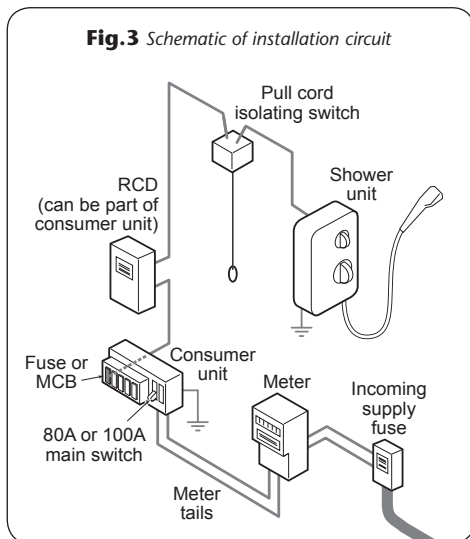

- 2 Before making any sort of electrical connection within the installation make sure that no terminal is live. If in any doubt, switch off the whole installation at the mains supply and remove the correct fuse.
- 3 The shower must be connected to its own independent electrical circuit. IT MUST NOT be connected to a ring main, spur, socket outlet, lighting circuit or cooker circuit.
- 3.1 The electrical supply must be adequate for the loading of the unit and existing circuits.
- 4 Check your consumer unit (main fuse box) has a main switch rating of 80A or above and that it has a spare fuse way which will take the fuse or Miniature Circuit Breaker (MCB) necessary for the shower (**Fig.4**).
- 4.1 If your consumer unit has a rating below 80A or if there is no spare fuse way, then the installation will not be straightforward and may require a new consumer unit serving the house or just the shower.
- 4.2 You will need to contact the local electricity company. They will check the supply and carry out what is necessary.
- 5 For close circuit protection DO NOT use a rewirable fuse. Instead use a suitably rated Miniature Circuit Breaker (MCB) or cartridge fuse (**see Table A**).
- 5.1 A 30mA residual current device (RCD) must be installed in all UK electric and pumped shower circuits. This may be part of the consumer unit or a separate unit.

**Table A**

unit rating	CIRCUIT PROTECTION	
	MCB	cartridge fuse
7.0kW	30/32A	30A
7.5kW	32A	35A
8.0kW	40A	35A
8.5kW	40A	45A
9.0kW	40A	45A
9.5kW	40/45A	45A
10.5kW	45A	45A

- 6 A 45 amp double pole isolating switch with a minimum contact gap of 3 mm in both poles must be incorporated in the circuit.
- 6.1 It must have a mechanical indicator showing when the switch is in the OFF position, and the wiring must be connected to the switch without the use of a plug or socket outlet.
- 6.2 The switch must be accessible and clearly identifiable, but out of reach of a person using a fixed bath or shower, except for the cord of a cord operated switch, and should be placed so that it is not possible to touch the switch body while standing in a bath or shower cubicle. It should be readily accessible to switch off after using the shower.
- 7 Where shower cubicles are located in any rooms other than bathrooms, all socket outlets in those rooms must be protected by a 30mA RCD.
- 8 The current carrying capacity of the cable must be at least that of the shower circuit protection (see Table B).
- 8.1 To obtain full advantage of the power provided by the shower, use the shortest cable route possible from the consumer unit to the shower.
- 8.2 It is also necessary to satisfy the disconnection time and thermal constraints which means that for any given combination of current demand, voltage drop and cable size, there is a maximum permissible circuit length.
- 9 The shower circuit should be separated from other circuits by at least twice the diameter of the cable or conduit.
- 9.1 The current rating will be reduced if the cabling is bunched with others, surrounded by thermal loft or wall insulation or placed in areas where the ambient temperature is above 30°C. Under these conditions, derating factors apply and it is necessary to select a larger cable size.
- 9.2 In the majority of installations, the cable will unavoidably be placed in one or more of the above conditions. This being so, it is strongly recommended to use a minimum of 10mm cabling throughout the shower installation.
- 9.3 In any event, it is essential that individual site conditions are assessed by a competent electrician in order to determine the correct cable size and permissible circuit length.

**Table B**

<b>Twin and earth PVC insulated cable Current carrying capacity</b>		
<b>Installed in an insulated wall</b>	<b>In conduit trunking</b>	<b>Clipped direct or buried in a non-insulated wall</b>
6 mm <sup>2</sup> 32A	6 mm <sup>2</sup> 38A	6 mm <sup>2</sup> 46A
10 mm <sup>2</sup> 43A	10 mm <sup>2</sup> 52A	10 mm <sup>2</sup> 63A
16 mm <sup>2</sup> 57A	16 mm <sup>2</sup> 69A	16 mm <sup>2</sup> 85A
<b>Note: Cable selection is dependent on derating factors</b>		

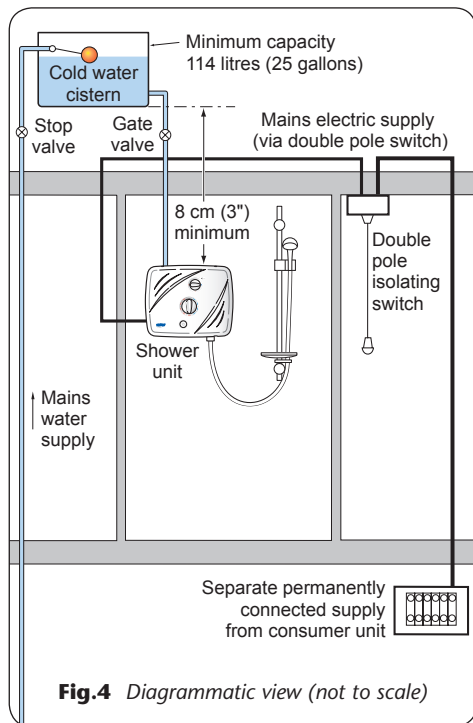

**Fig.4** Diagrammatic view (not to scale)

## WATER REQUIREMENTS

### WARNING!

**Under no circumstances must this shower be connected directly to the mains water supply.**

The installation must be in accordance with the Water Regulations/Bylaws.

To ensure activation of the heating elements, the shower must be connected to a cold water supply which is gravity fed from a static cold water storage cistern with a minimum capacity of 114 litres (25 gallons).

There must be a maximum head of water of 10 metres and a minimum head of 8 cm as measured between the bottom of the cistern and the top of the shower unit. There must be no other cold water draw-offs between the cistern and the unit and the pipe must not supply water to any other tap or fitting at a lower level.

**Note:** The supply pipe from the cistern should be on the opposite side to the float operated valve to prevent air being drawn into the pipe when the cistern is filling.

If it is intended to operate the shower in hard water areas (above 200 ppm temporary hardness) a scale inhibitor should be fitted.

**Fig.4** shows a typical system layout.

**DO NOT use jointing compounds on any pipe fittings for the installation.**



## SITING OF THE SHOWER

**IMPORTANT:** If installing onto a tiled wall always mount the unit on the surface of the tiles. NEVER tile up to the unit.

Refer to **fig.5** for correct siting of the shower.

Position the unit where it will NOT be in direct contact with water from the showerhead. Position the shower unit vertically.

Allow enough room between the ceiling and the shower to access the cover top screws.

**Note:** Water regulations require the showerhead be 'constrained by a fixed or sliding attachment so that it can only discharge water at a point not less than 25 mm above the spill-over level of the relevant bath, shower tray or other fixed appliance'. The use of the supplied soap dish will in most cases meet this requirement, but if the showerhead can be placed within a bath, basin or shower tray, then a double check valve, or similar, must be fitted in the supply pipework to prevent back-flow.

Allow enough room between the ceiling and the shower to access the cover top screws.

### Pressure relief safety device

A pressure relief device (PRD) is designed into the shower unit which complies with European standards. The PRD provides a level of appliance protection should an excessive build up of pressure occur within the shower.

**DO NOT** operate the shower with a damaged or kinked shower hose, or a blocked showerhead which can cause the PRD to operate.

When commissioning, the showerhead must be removed from the flexible hose. Failure to follow this procedure may also result in causing the PRD to operate.

Make sure the shower is positioned over a bath or shower tray because if the PRD operates, then water will eject from the bottom of the unit.

Should this happen, turn off the electricity and water supplies to the shower at the isolating switch and stopvalve. Contact Customer Service for advice on replacing the PRD.

**WARNING!**  
The shower must not be positioned where it will be subjected to freezing conditions.

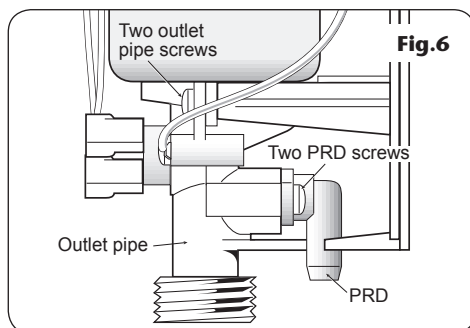
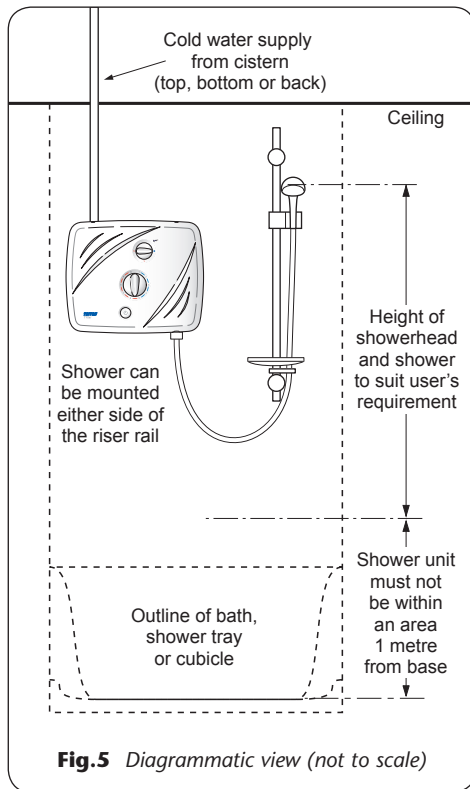
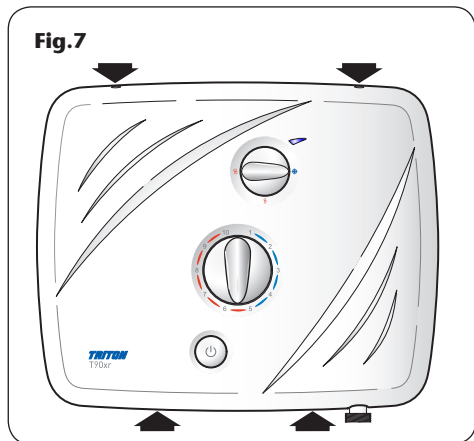

Fig.7



The PRD is situated behind the outlet pipe (**fig.6**). To access the PRD, FIRST SWITCH OFF THE ELECTRICITY SUPPLY, unscrew the hose then remove the cover. Remove the two screws holding the outlet pipe to the base of the can. Carefully pull away from the can and then unscrew the two screws holding the PRD to the outlet pipe.

**CAUTION:** Do not attempt to replace the PRD unless competent to do so.

**Note:** Before replacing the cover, it is strongly advised to prime the unit (see 'commissioning').

Fig.8

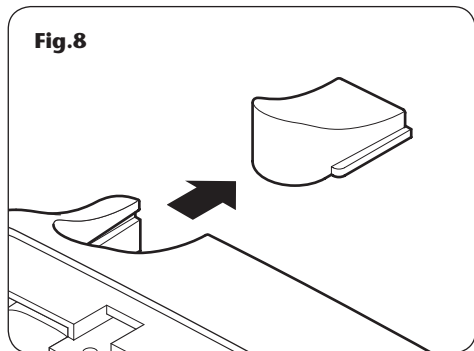

## FITTING THE SHOWER TO THE WALL

**Note:** The control knobs are an integral part of the cover – DO NOT attempt to remove them.

**IMPORTANT:** The unit must be mounted on a flat surface which covers the full width and length of the backplate. It is important that the wall surface is flat otherwise difficulty may be encountered when fitting the cover and subsequent operation of the unit may be impaired.

Unscrew the two top and two bottom retaining screws (**fig.7**) and lift the cover from backplate.

If a top entry is required for the water pipe, then remove the top insert from the backplate (**fig.8**).

If a bottom entry is required for the cold water pipe, then a hole will need to be cut out of the trimplate (**fig.9**).

If entry is from the back, the nut of the compression fitting will be partially behind the surface of the wall (**fig.10**). This area must be left clear when plastering over the pipework to make the nut accessible for future adjustments.

**IMPORTANT:** Using a suitable sealant, always seal around the incoming pipework to prevent water entering the wall.

**Note:** Deviations from the designated entry points will invalidate product approvals.

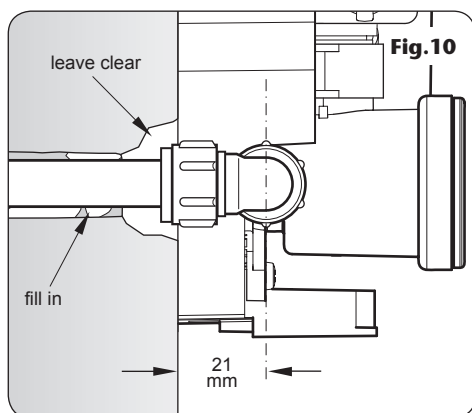
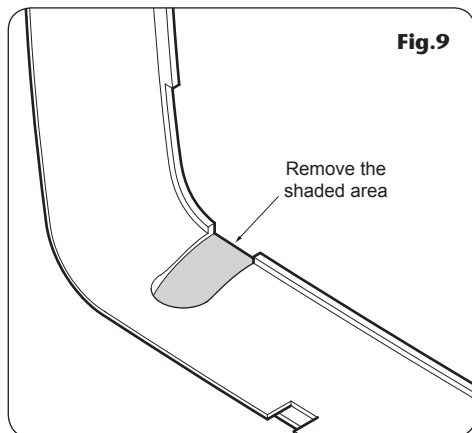

**Fig.11**

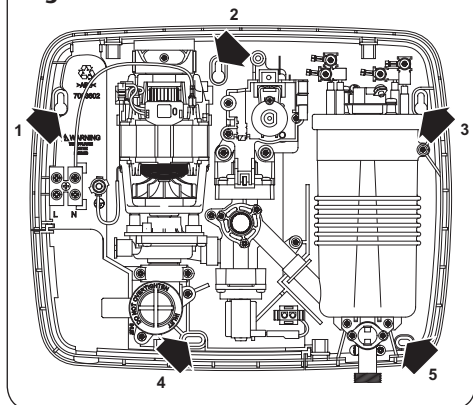

After choosing the site for the shower, use the backplate as a template (**fig.11**) and mark the four fixing holes 1, 3, 4 and 5.

**Note:** If fixing to an installation with a top water entry point, mark the four fixing holes 2, 3, 4 and 5.

Drill and plug to suit the fixing screws supplied. *(The wall plugs provided are suitable for most brick walls – use an appropriate masonry drill, but if the wall is plasterboard or a soft building block, use suitable wall plugs and an appropriate drill bit.)*

Screw the two upper fixing screws into position leaving the base of the screw heads protruding 6 mm out from the wall.

Hook the backplate over the top screws and fit the lower fixing screw into position.

DO NOT fully tighten the screws at this stage, as the fixing holes are elongated to allow for out of square adjustment after the plumbing connections have been completed.

**Note:** A temporary factory fitted locking screw is fitted to the power selector spindle (**fig.16**). This is to make sure the spindle is held in Cold while the commissioning procedure is carried out.

**DO NOT remove the locking screw before this procedure is completed.**

## PLUMBING CONNECTIONS

### *Plumbing to be carried out before wiring*

DO NOT use jointing compounds on any pipe fittings for the installation.

DO NOT solder fittings near the shower unit as heat can transfer along the pipework and can damage components.

**Note:** An additional gate valve or fullway lever valve must be fitted in the water supply to the shower as an independent means of isolating the water supply should maintenance or servicing be necessary.

### *Procedure*

Turn off water supply either at the mains stopvalve or the isolating stopvalve to the cistern. Drain the cistern.

**IMPORTANT:** The pipework must be brought direct from the cold water storage cistern with no other cold water draw-offs between the shower and the cistern.

**IMPORTANT:** Before completing the connection of the water supply to the inlet of the shower, flush out the pipework to remove all swarf and system debris. This can be achieved by connecting a hose to the pipework and turning on the water supply long enough to clear the debris to waste.

Connect the water supply to the inlet of the shower via 15 mm copper, stainless steel or plastic pipe using a 15 mm x 15 mm elbow compression fitting. Do not use excessive force when making these connections.

Although the pipework connection to the shower is via 15 mm diameter pipework, on long runs use 22 mm diameter piping as far as possible to avoid restricting the flow to the shower.

Make sure that the backplate of the unit is flat on the wall and positioned squarely. Tighten the fixing screws.

Turn on the water supply and check for leaks in the pipework connection to the shower.

**Note:** At this stage no water can flow through the unit.

Locate the trimplate to the two guides on the backplate and slide into position.

### **WARNING!**

**The outlet of the shower acts as a vent and MUST NOT be connected to anything other than the hose and showerhead supplied.**

Fig.12

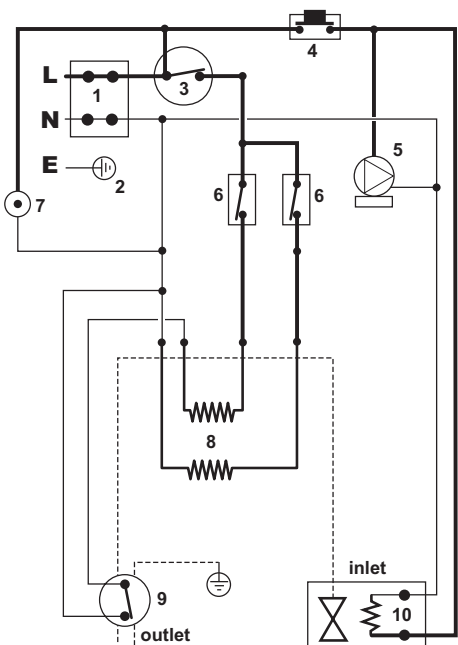

- |                           |                           |
|---------------------------|---------------------------|
| 1. Terminal block         | 6. Selector microswitches |
| 2. Earth post             | 7. Neon indicator         |
| 3. Thermal cut-out (main) | 8. Elements               |
| 4. Start/Stop button      | 9. Thermal cut-out        |
| 5. Pump and motor assy.   | 10. Solenoid valve        |

## ELECTRICAL CONNECTIONS

SWITCH OFF THE ELECTRICITY SUPPLY AT THE MAINS.

Fig.12 shows a schematic wiring diagram.

The cable entry points are shown in fig.1.

The cable can be surface clipped, hidden or via 20 mm conduit.

**Note:** Conduit entry can only be from rear. Route the cable into the shower unit and connect to the terminal block (fig.13) as follows:

Earth cable to terminal marked **E** ⊕

Neutral cable to terminal marked **N**

Live cable to terminal marked **L**

**IMPORTANT:** Fully tighten the terminal block screws and make sure that no cable insulation is trapped under the screws. Loose connections can result in cable overheating.

**Note:** The supply cable earth conductor must be sleeved. The outer sheath of the supply cable must be stripped back to the minimum.

The supply cable must be secured either by routing through conduit or in trunking or by embedding in the wall, in accordance with current IEE regulations.

The use of connections within the unit, or other points in the shower circuit, to supply power to other equipment i.e. extractor fans, pumps etc. will invalidate the guarantee.

**DO NOT** switch on the electricity supply until the cover has been fitted.

**Note:** The elements on UK models are to 240V specification and will give a lower kW rating if the voltage supply is below 240V.

Fig.13

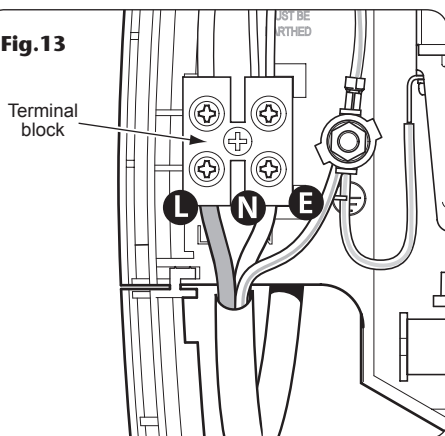

## COMMISSIONING

### WARNING!

**Do not switch on the electricity supply until the commissioning procedure has been completed and the cover has been fitted. Failure to do so could cause the pump to run dry and invalidate the guarantee.**

The first operation of the shower is intended to flush out any remaining unit debris, and to ensure the heater unit contains water before the elements are switched on.

This operation must be carried out with the flexible hose screwed to the outlet but without the showerhead attached. Make sure the outlet of the flexible hose is directed to waste and power selector set to the Cold position.

To check that the temperature control is correctly positioned on the stabilising valve, temporarily place the cover in position so that the splines engage then rotate the temperature control fully anti-clockwise.

Remove the cover and position the temperature control so that it points towards '1' (**fig.14**).

Position the power selector to the Cold position (**fig.15**).

DO NOT remove the locking screw fitted to the power selector spindle (**fig.16**) – it can be removed only when the commissioning procedure has been completed.

Make sure the water supply is still turned on to the shower.

Open the bleed screw on the pump unit (**fig.17**) by rotating one revolution. When water flows from the opening, this indicates that any trapped air is vented and that the pump unit is primed. The bleed valve must now be closed by rotating in the opposite direction.

Offer the cover to the backplate unit. Make sure the power selector is still at the Cold position and the temperature control is at '1'.

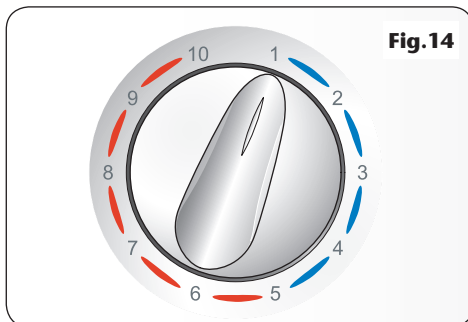

Fig.14

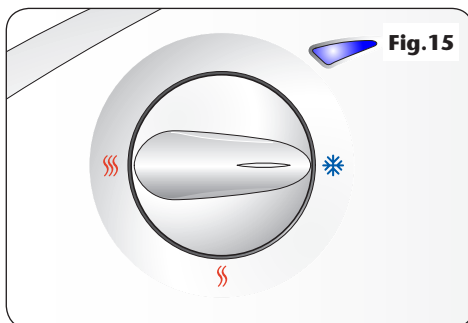

Fig.15

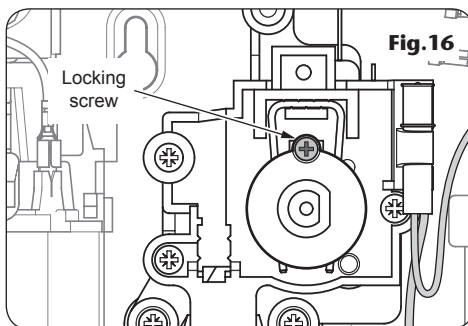

Fig.16

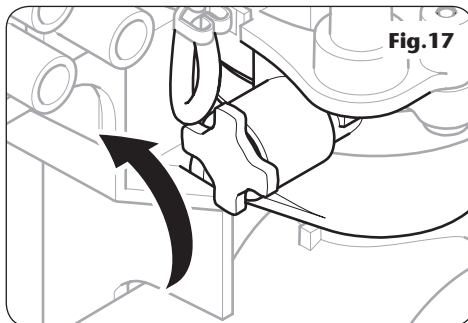

Fig.17

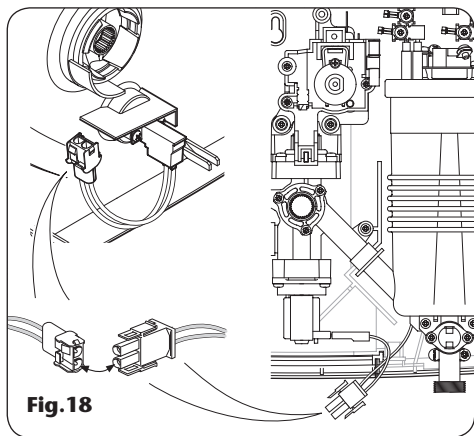

Fig. 18

**Note:** Make sure the Start/Stop button is not depressed in the cover which indicates 'START'. The button should be flush with the cover, otherwise water will flow as soon as the electricity is switched on.

Attached to the Stop/Start switch inside the cover is a two wire lead. The socket on the end of this lead must be connected to the plug that is situated at the bottom of the right-hand side of the backplate unit (**fig.18**).

**Note:** The plug and socket can only fit one way. Take care to ensure the flexible drip shield around the solenoid is positioned correctly (**fig.19**).

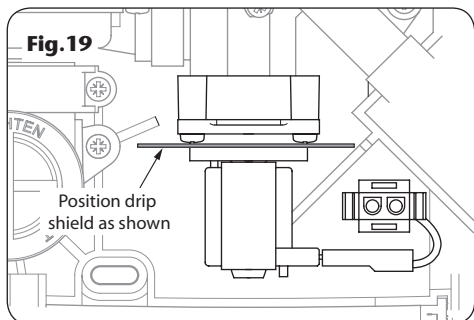

Fig. 19

Replace the cover squarely to the backplate and guide into position so that the controls locate correctly into the spindles while at the same time, making sure the wires are not trapped.

Should any difficulty arise, recheck the points above.

Secure the cover temporarily in position with two retaining screws. **DO NOT OVERTIGHTEN.** Switch on the mains electric supply to the shower at the isolating switch.

Press the Start/Stop button (**fig.20**). The power indicator will light and the pump starts to operate.

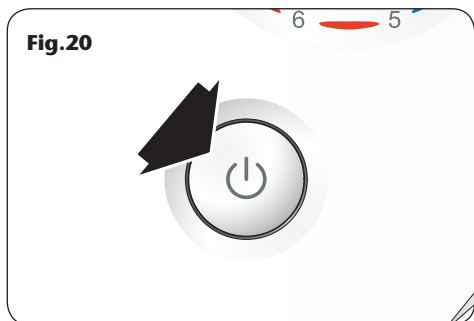

Fig. 20

It will take about thirty seconds for a smooth flow of water to be obtained while air and any debris is being flushed from the shower.

When a smooth flow of water is obtained, rotate the temperature control from '1' to '10' several times (**fig.21**) to release any trapped air within the unit.

Once flushing out has been completed, stop the water flow by pressing the Start/Stop button.

**SWITCH OFF THE ELECTRICITY SUPPLY TO THE SHOWER AT THE ISOLATING SWITCH.**

Unscrew the cover retaining screws again and lift the cover from the backplate.

Remove the locking screw from the power selector spindle (**fig.16**) and store for future use. Make sure the selector spindle is left in the same attitude.



Replace the cover as described above and permanently secure with the four retaining screws.

**IMPORTANT:** Take care to ensure that the four screws securing the cover are fully tightened – failure to do so may affect compliance with the IPX4 test. **DO NOT OVERTIGHTEN.**

Switch the mains electric supply back on to the shower at the isolating switch. Once the showerhead and riser rail are fitted, the shower is ready for normal use.

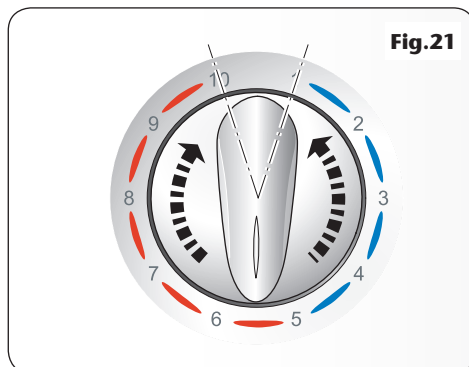

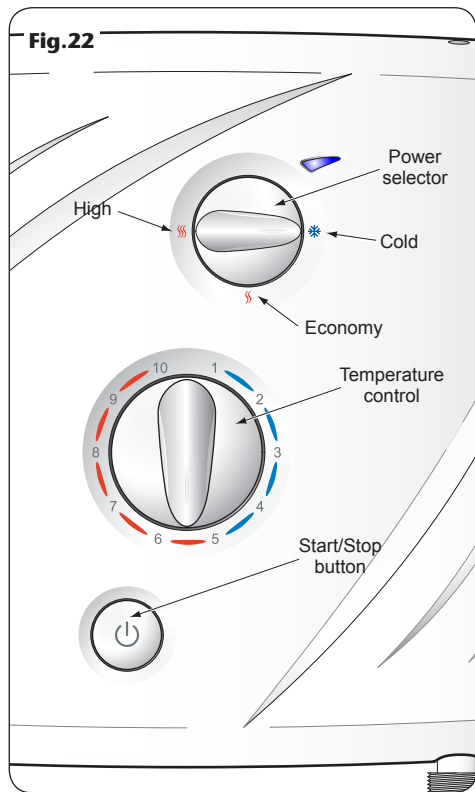

**Note:** In normal use, it is in order to leave the water supply permanently on to the shower unit, but as with most electrical appliances, **the unit must be switched off at the isolating switch when not in use.**

## OPERATING THE SHOWER

### WARNING!

**Before normal operation of the shower, it is essential that the commissioning procedure has been completed correctly.**

Press the Start/Stop button. This switches off the pump and the water flow will cease.

### To use the power selector

The power selector (**fig.22**) has three settings: COLD, ECONOMY and HIGH.

The blue symbol ❄️ is COLD water only. Adjusting the temperature control at this setting will only increase or decrease the force of the

### WARNING!

**If restarting immediately after stopping, be aware that a slug of hot water will be expelled for the first few seconds.**

water from the showerhead. It will not alter the water temperature.

The red symbol 🌀 is the ECONOMY setting for using less energy during warmer months and any temperature adjustment at this setting is via the temperature control.

The red symbol 🌀 is the HIGH power setting which allows the highest flow achievable for your preferred temperature. Temperature adjustment at this setting is via the temperature control.

### **To adjust the shower temperature**

The shower temperature is altered by increasing or decreasing the flow rate of the water through the shower via the temperature control.

After obtaining your preferred shower temperature, the number can be remembered as the normal setting and should only need to be altered to compensate for seasonal changes in ambient water temperatures.

### **To decrease the shower temperature**

Turn the temperature control anti-clockwise towards the lower numbers; this will increase the water flow.

### **To increase the shower temperature**

Turn the temperature control clockwise towards the higher numbers; this will decrease the water flow.

**Note:** It is advisable to be certain that the showering temperature is satisfactory by testing with your hand before stepping under the showerhead.

There will always be a time delay of a few seconds between selecting a flow rate and the water reaching the stable temperature for that flow rate.

**CAUTION:** It is recommended that persons who may have difficulty understanding or operating the shower controls should not be left unattended while showering. Special consideration should be given to young children and the less able bodied.

#### **WARNING!**

**After any servicing of mains water supply, always flush out the pipework to remove any debris.**

**Always make sure the unit is started on COLD in order to purge any air in the pipework.**

#### **WARNING!**

**This appliance is not intended for use by young children or infirm persons unless they have been adequately supervised by a responsible person to ensure that they can use the appliance safely.**

**Young children should be supervised to ensure that they do not play with the appliance.**

**WARNING!**

**DO NOT use abrasive or aggressive cleaning products when cleaning the shower as they may damage the unit.**

**OPERATING FUNCTIONS****Power on indicator (fig.23)**

The power neon will light when the electrical supply to the unit is switched on. This indicates that power is on to the pump and power selector.

**Low water pressure cut-out**

Should the water pressure fall below the minimum required to operate the shower, power will be switched off to the heating elements preventing any maintained temperature rises.

**Overheat cut-out**

During normal operation if an overheat temperature is sensed, power to the elements will be reduced. Water will continue to flow. When the temperature has cooled enough, power to the elements will be automatically restored to the setting at the time of interruption.

**Safety cut-out**

The unit is fitted with a non-resettable over-temperature safety device. In the event of abnormal operation which could cause unsafe temperatures within the unit, the device will disconnect the heating elements. It will require a visit from a qualified engineer to determine the nature of the fault and replace the safety device, once the unit has been repaired.

**CLEANING**

Triton Plc recommends that all products are cleaned using warm, soapy water.

DO NOT use abrasive or aggressive chemical cleaning products as this may affect the product surface finish and invalidate your guarantee.

## INSTRUCTIONS FOR INSTALLERS AND SERVICE ENGINEERS ONLY

### CLEANING THE FILTER

It is recommended that the filter is periodically cleaned in order to maintain the performance of the shower. It is essential that this operation is carried out by a competent person.

#### SWITCH OFF THE ELECTRICITY SUPPLY AT THE MAINS.

Remove the cover and disconnect the plug.

**Note:** Should debris be trapped on the shut off seat inside the valve, water will continue to flow out as the filter is removed. It is advisable to switch off the incoming water supply before removing the filter.

DO NOT rely on the filter shut off valve when carrying out repairs or service to other areas of the shower unit.

Unscrew the filter (**fig.24**) by turning anti-clockwise. Remove the unit complete with the filter and wash under running water. Make sure all debris is removed.

Replace by pushing the unit back into its housing until the threads engage and then turn fully clockwise until tight. DO NOT OVERTIGHTEN.

Before replacing the cover, it is strongly advised to prime the unit by opening the bleed screw until water drains from it.

Close the bleed screw and connect the plug to the cover. Replace the cover and secure with the fixing screws.

Switch on the electric supply and start the shower on the COLD SETTING ONLY and with the temperature control rotated fully anti-clockwise.

When a smooth flow of water is obtained, the shower can then be used in the normal manner.

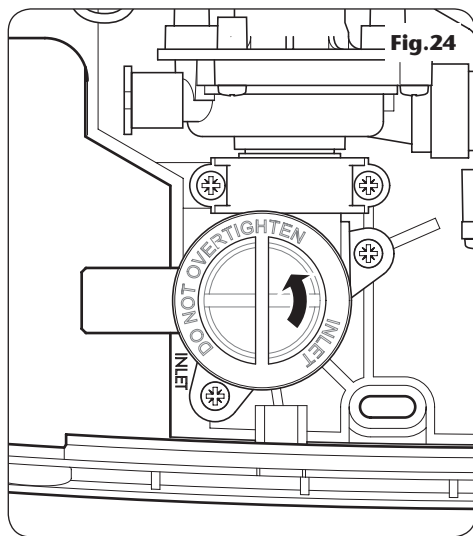

# T90xr pumped electric shower

## SPARE PARTS

*Triton only supply spare parts for this model as illustrated. NO component of any assembly can be supplied separately.*

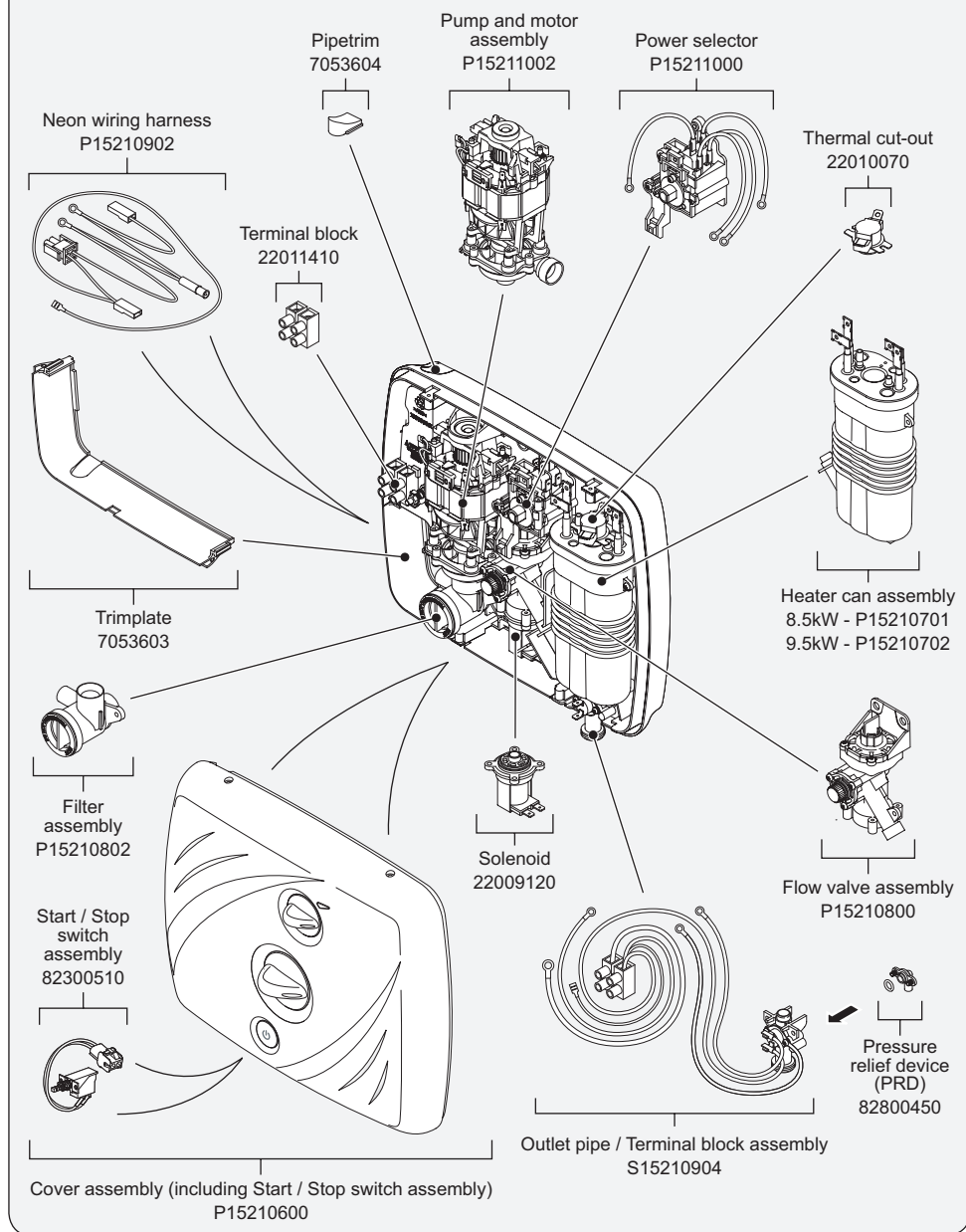

## FAULT FINDING

**IMPORTANT:** Switch OFF the electricity at the mains supply and remove the circuit fuse before attempting any fault finding inside the unit.

<b>Problem/Symptom</b>	<b>Cause</b>	<b>Action/Cure</b>
<b>1</b> Shower inoperable, no water flow when the start/stop button is pressed.	<b>1.1</b> Interrupted power supply.	<b>1.1.1</b> Check if a general power cut. Check other appliances and if necessary, contact the local Electricity Supply Company. <b>1.1.2</b> If the power neon does not illuminate when the Start/Stop button is pressed, check the consumer unit fuse or circuit breaker or isolating switch. If blown or faulty, renew or reset as applicable. If it fails again, consult a competent electrician.
	<b>1.2</b> Plug not connected to socket inside the cover.	<b>1.2.1</b> Remove the cover and make sure the plug and socket are firmly connected.
	<b>1.3</b> Solenoid valve malfunction.	<b>1.3.1</b> Have solenoid checked by a competent electrician or contact Customer Service.
	<b>1.4</b> Pump motor faulty.	<b>1.4.1</b> If the power neon is lit when the Start/Stop button is pressed, have the pump checked by a competent person or contact Customer Service.
<b>2</b> Water too hot.	<b>2.1</b> Not enough water flowing through the shower.	<b>2.1.1</b> Increase flow rate via temperature control. <b>2.1.2</b> Blocked showerhead – clean or replace blocked sprayplate in showerhead.
	<b>2.2</b> Increase in ambient water temperature.	<b>2.2.1</b> Switch to reduced power setting and readjust flow rate (via temperature control) to give the required temperature.
<b>3</b> Water temperature cycling hot/cool at intervals.	<b>3.1</b> Heater cycling on outlet thermal cut-out.	<b>3.1.1</b> See 'Water too hot' causes 2.1 and 2.2 and their appropriate action/cures. If it continues, contact Customer Service.
<b>4</b> Water too cool or cold.	<b>4.1</b> Too much flow.	<b>4.1.1</b> Reduce flow rate via temperature control.
	<b>4.2</b> Reduction in the ambient water temperature.	<b>4.2.1</b> Switch to full power setting and readjust the flow rate using the temperature control to give the required temperature.
	<b>4.3</b> Electrical malfunction or safety cut-out has operated.	<b>4.3.1</b> Have the shower unit checked by a competent electrician or contact Customer Service.

## FAULT FINDING

<b>Problem/Symptom</b>	<b>Cause</b>	<b>Action/Cure</b>
<b>5</b> During use, the water flow ceases abruptly.	<b>5.1</b> Interrupted power supply.	<b>5.1.1</b> See 1.1.1 and 1.1.2.
	<b>5.2</b> Solenoid valve malfunction (pump still operates).	<b>5.2.1</b> Switch off immediately. Have solenoid checked by a competent electrician or contact Customer Service.
	<b>5.3</b> Pump motor faulty.	<b>5.3.1</b> See 1.5.1.
<b>6</b> Shower performance drops, indicated by a gradual reduction in water flow.	<b>6.1</b> Water starvation to the unit.	<b>6.1.1</b> Check the filter is not blocked. First, isolate the electricity supply and then remove the cover.
		<b>6.1.2</b> Check the cold water cistern is full.
		<b>6.1.3</b> Make sure the water supply pipe is not blocked or air locked.
		<b>6.1.4</b> Check there is no simultaneous demand from the cistern during showering.
		<b>6.1.5</b> Reprime the unit without electricity switched on to the unit (see 'commissioning').
<b>7</b> Pressure relief device has operated (water ejected from the PRD tube)	<b>7.1</b> Blocked showerhead.	<b>7.1.1</b> Clean or replace blocked showerhead and then fit a new PRD.
	<b>7.2</b> Twisted/blocked flexible shower hose.	<b>7.2.1</b> Check for free passage through the hose. Replace the hose if necessary and then fit a new PRD.
	<b>7.3</b> Showerhead not removed while commissioning.	<b>7.3.1</b> Fit a new PRD. Commission the unit with showerhead removed.
<b>8</b> Shower fails to shut off when STOP button is pressed.	<b>8.1</b> START/STOP button failure.	<b>8.1.1</b> Isolate from electricity supply and call Triton customer services.

**Note:** Identify cause of operation before fitting new PRD unit. When fitting a new PRD, follow the commissioning procedure.

**It is advised all electrical maintenance/repairs to the shower should be carried out by a suitably qualified person.**









## Service Policy

In the event of a complaint occurring, the following procedure should be followed:

- 1 Telephone Customer Service on: 0870 067 3333 (0845 762 6591 in Scotland and in Northern Ireland), having available the model number and power rating of the product, together with the date of purchase.
- 2 Triton Customer Service will be able to confirm whether the fault can be rectified by either the provision of a replacement part or a site visit from a qualified Triton service engineer.
- 3 If a service call is required the unit must be fully installed for the call to be booked and the date confirmed. In order to speed up your request, please have your postcode available when booking a service call.
- 4 It is essential that you or an appointed representative (who must be a person of 18 years of age or more) is present during the service engineer's visit and receipt of purchase is shown.
- 5 A charge will be made in the event of an aborted service call by you but not by us, or where a call under the terms of guarantee has been booked and the failure is not product related (i.e. scaling and furring, incorrect water pressure, pressure relief device operation, electrical installation faults).
- 6 If the product is no longer covered by the guarantee, a charge will be made for the site visit and for any parts supplied.
- 7 Service charges are based on the account being settled when work is complete, the engineer will then request payment for the invoice. If this is not made to the service engineer or settled within ten working days, an administration charge will be added.

## Replacement Parts Policy

**Availability:** It is the policy of Triton to maintain availability of parts for the current range of products for supply after the guarantee has expired. Stocks of spare parts will be maintained for the duration of the product's manufacture and for a period of five years thereafter.

In the event of a spare part not being available a substitute part will be supplied.

**Payment:** The following payment methods can be used to obtain spare parts:

- 1 By post, pre-payment of pro forma invoice by cheque or money order.
- 2 By telephone, quoting credit card (MasterCard or Visa) details.
- 3 By website order, [www.tritonshowers.co.uk](http://www.tritonshowers.co.uk)

## TRITON STANDARD GUARANTEE

Triton guarantee this product against all mechanical and electrical defects arising from faulty workmanship or materials for a period of one year for domestic use only, from the date of purchase, provided that it has been installed by a competent person in full accordance with the fitting instructions.

Any part found to be defective during this guarantee period we undertake to repair or replace at our option without charge so long as it has been properly maintained and operated in accordance with the operating instructions, and has not been subject to misuse or damage.

This product must not be taken apart, modified or repaired except by a person authorised by Triton. This guarantee applies only to products installed within the United Kingdom and does not apply to products used commercially. This guarantee does not affect your statutory rights.

### What is not covered:

- 1 Breakdown due to: *a)* use other than domestic use by you or your resident family; *b)* wilful act or neglect; *c)* any malfunction resulting from the incorrect use or quality of electricity, gas or water or incorrect setting of controls; *d)* faulty installation.
- 2 Repair costs for damage caused by foreign objects or substances.
- 3 Total loss of the product due to non-availability of parts.
- 4 Compensation for loss of use of the product or consequential loss of any kind.
- 5 Call out charges where no fault has been found with the appliance.
- 6 The cost of repair or replacement of pressure relief devices, showerheads, hoses, riser rails and/or wall brackets, isolating switches, electrical cable, fuses and/or circuit breakers or any other accessories installed at the same time.
- 7 The cost of routine maintenance, adjustments, overhaul modifications or loss or damage arising therefrom, including the cost of repairing damage, breakdown, malfunction caused by corrosion, furring, pipe scaling, limescale, system debris or frost.

**Customer Service:** ☎ 0870 067 3333

**Scottish and Northern Ireland  
Customer Service:** ☎ 0845 762 6591

**Trade Installer Hotline:** ☎ 0870 067 3767  
Fax: 0870 067 3334

[www.tritonshowers.co.uk](http://www.tritonshowers.co.uk)

**E mail:** [technical@tritonshowers.co.uk](mailto:technical@tritonshowers.co.uk)

Triton Showers  
Triton Road  
Nuneaton  
Warwickshire CV11 4NR

*Triton is a division of Norcross Group (Holdings) Limited*

**Extended Warranty AVAILABLE NOW. Call 0870 067 3333 for more details.**