

Section 2
Installation

2.1 *Before Installation*

Please read the following notes concerning installation and connection before installing the system and terminal equipment.

Safety Installation Instructions

When installing telephone wiring, basic safety precautions should always be followed to reduce the risk of fire, electric shock and injury to persons, including the following:

1. Never install telephone wiring during a lightning storm.
2. Never install telephone ports in wet locations unless the port is specifically designed for wet locations.
3. Never touch uninsulated telephone wires or terminals unless the telephone line has been disconnected at the network interface.
4. Use caution when installing or modifying telephone lines.

Installation Precautions

This system is designed for wall mounting only. Avoid installing in the following places. (Doing so may result in malfunction, noise, or discolouration.)

1. In direct sunlight and hot, cold, or humid places. (Temperature range: 0 °C – 40 °C)
2. Sulphuric gases produced in areas where there are thermal springs, etc. may damage the equipment or contacts.
3. Places in which shocks or vibrations are frequent or strong.
4. Dusty places, or places where water or oil may come into contact with the system.
5. Near high-frequency generating devices such as sewing machines or electric welders.
6. On or near computers, telexes, or other office equipment, as well as microwave ovens or air conditioners. (It is preferable not to install the system in the same room with the above equipment.)
7. Install at least 1.8 m away from radios and televisions. (Both the system and Panasonic proprietary telephones)
8. Do not obstruct area around the system (for reasons of maintenance and inspection — be especially careful to allow space for cooling above and at the sides of the system).

Wiring Precautions

Be sure to follow these instructions when wiring the unit:

1. Do not wire the telephone cable in parallel with an AC power source, computer, telex, etc. If the cables are run near those wires, shield the cables with metal tubing or use shielded cables and ground the shields.
2. If cables are run on the floor, use protectors to prevent the wires from being stepped on. Avoid wiring under carpets.
3. Avoid using the same power supply outlet for computers, telexes, and other office equipment. Otherwise, the system operation may be interrupted by the induction noise from such equipment.

2.1 Before Installation

4. Please use one pair telephone wire for extension connection of (telephone) equipment such as single line telephones, data terminals, answering machines, computers, voice processing systems, etc., except Panasonic proprietary telephones (e.g. KX-T7130).
5. Unplug the system during wiring. After all of the wiring is completed, plug in the system.
6. Mis-wiring may cause the system to operate improperly. Refer to Section 6.1 “While Installing” and Section 6.2 “While Connecting”.
7. If an extension does not operate properly, disconnect the telephone from the extension line and then connect again, or turn off the Power Switch of the system and then on again.
8. The system is equipped with a 3-wire grounding type plug. This is a safety feature. If you are unable to insert the plug into the outlet, contact your electrician to replace your obsolete outlet. Do not defeat the purpose of the grounding-type plug.
9. Exchange lines should be installed with lightning protectors. For details, refer to Section 2.7 “Exchange Line Connection”, Installing Lightning Protectors.

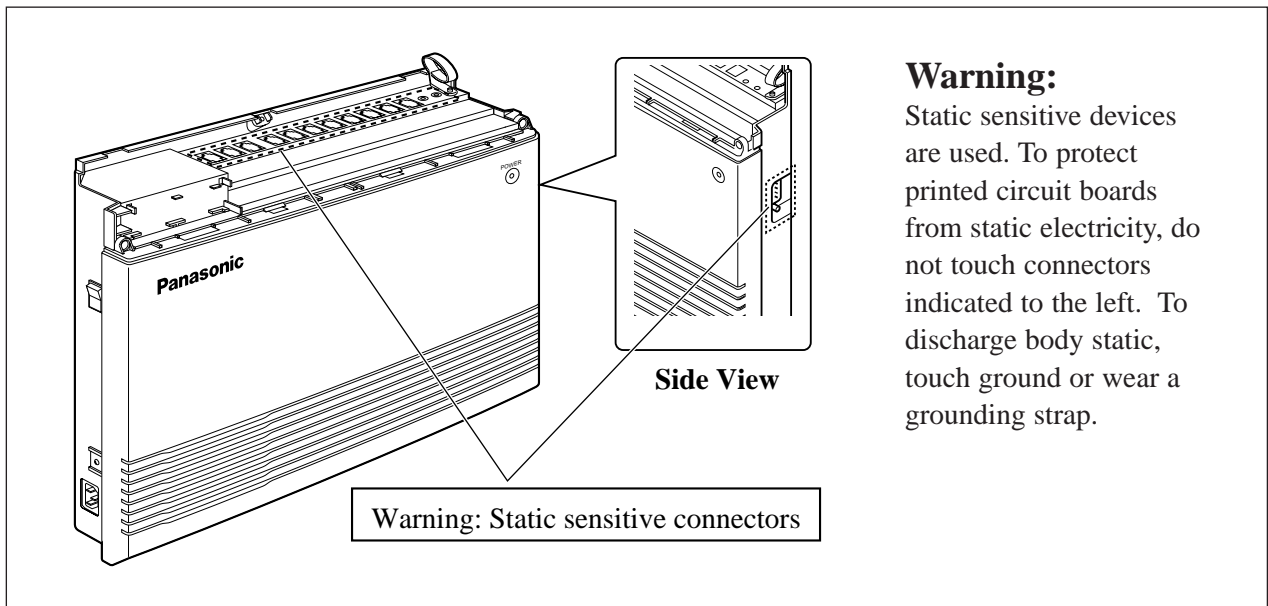

2.2 Unpacking

Unpack the box and check the items below.

| | | | |
|---|---|---|---|
| Main Unit | 1 | Music Source Connector Order No. PQJP1E1Z | 1 |
| AC Cord Order No. PSWAT206E | 1 | Installation Manual Order No. PSQX1708Y | 1 |
| Telephone Line Cords (2-conductor wiring) Order No. PSJA1066Z | 3 | Operating Instructions Order No. PSQX1709Y | 1 |
| Telephone Line Cords (4-conductor wiring) Order No. PQJA151Z | 8 | Operating Instructions for the Caller ID Card Order No. PSQX1744Y | 1 |
| Screws (Wall Mounting) Order No. PQHE5004Z | 3 | SLT User Guide Order No. PSQX1753Z | 2 |
| Washers (Wall Mounting) Order No. XWG35FY | 3 | System Clear Leaflet Order No. PSQW1412Y | 1 |
| Pager Connector Order No. PQJP1E1Z | 1 | Feature Number Leaflet Order No. PSQW1472Y | 1 |

Optional Cards (For your reference)

| KX-TA62460 | | KX-TA62474 | | KX-TA62477 | |
|---|---|--|---|--|---|
| Screws Order No. XYN3+F12FN | 1 | Screws Order No. XYN3+F8 | 2 | Extension Bolts Order No. PSHE1051Z | 2 |
| Terminal Boxes Order No. PQJS1T30Z | 2 | Extension Connectors Order No. PSJP36A67Z | 2 | Extension Connectors Order No. PSJP36A67Z | 2 |
| Telephone Line Cords (4-conductor wiring) Order No. PQJA48W | 2 | | | Spacer Order No. PSHR1172Z | 1 |

2.3 Names and Locations

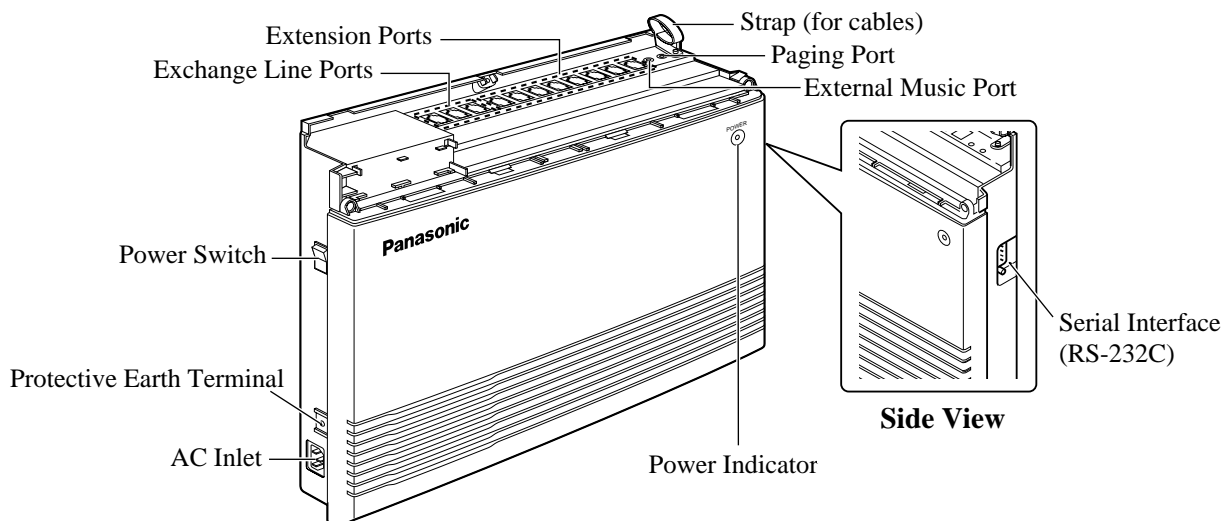

2.4 *Wall Mounting*

This set is designed for wall mounting only. The wall where the main unit is to be mounted must be able to support the weight of the main unit. If screws other than the ones supplied are used, use screws with the same diameter as the ones enclosed.

Mounting on a Wooden Wall

1. Place the template (on the last page) on the wall to mark the screw positions.

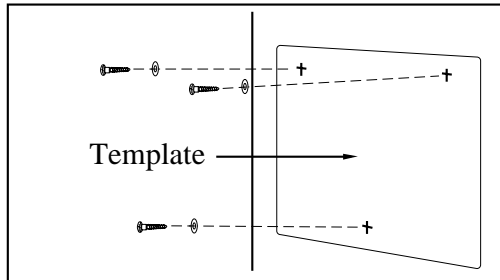

2. Install the screws (included) into the wall.

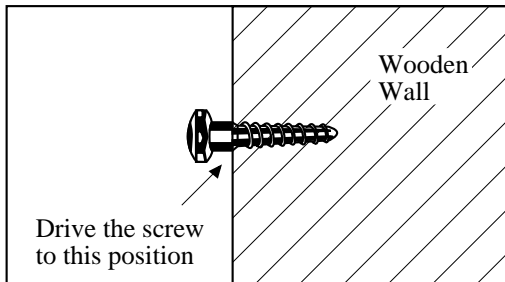

3. Hook the main unit on the screw heads.

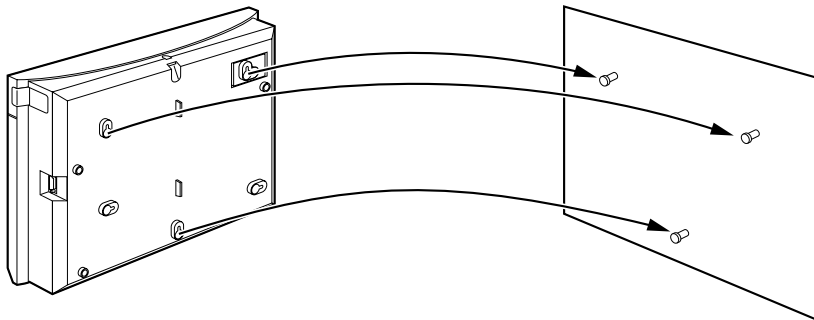

2.5 Frame Ground Connection

IMPORTANT!!!

Connect the frame of the main unit to the ground.

1. Loosen the screw.
2. Insert the grounding wire (user-supplied).
3. Tighten the screw.
4. Connect the grounding wire to the ground.

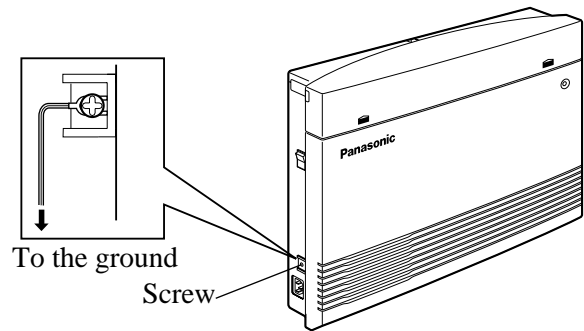

2.6 Opening the Top Front Cover

1. Loosen the screw.
2. Remove the top front cover.

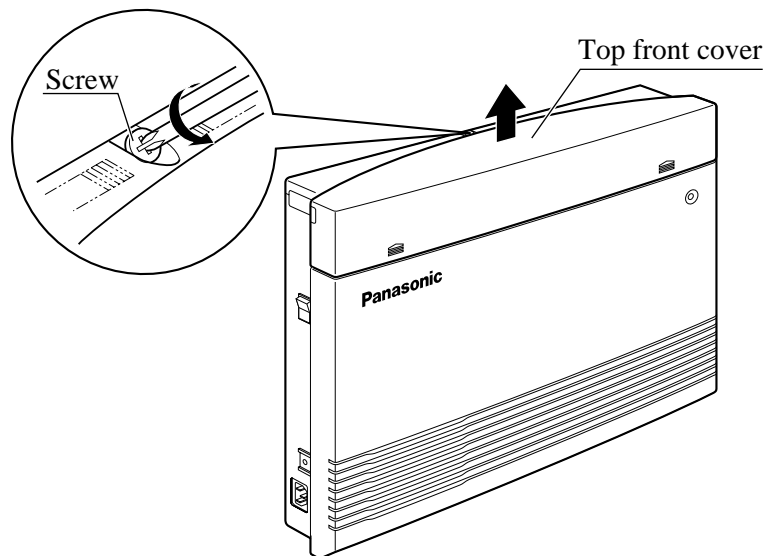

- ! • The screw cannot be removed from the cover.

2.5 Frame Ground Connection

IMPORTANT!!!

Connect the frame of the main unit to the ground.

1. Loosen the screw.
2. Insert the grounding wire (user-supplied).
3. Tighten the screw.
4. Connect the grounding wire to the ground.

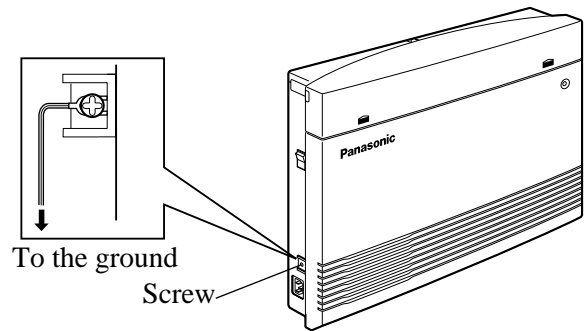

2.6 Opening the Top Front Cover

1. Loosen the screw.
2. Remove the top front cover.

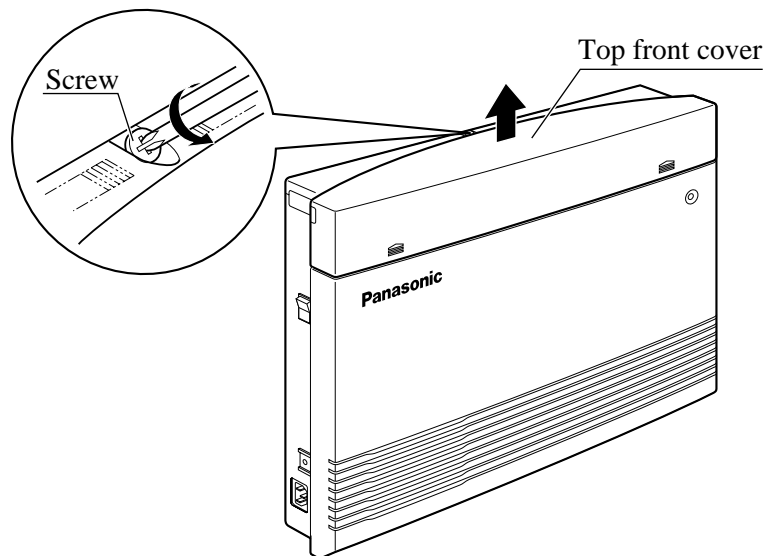

- !**
- The screw cannot be removed from the cover.

2.19 *Securing the Cords*

1. Wrap the strap around all of the cords.

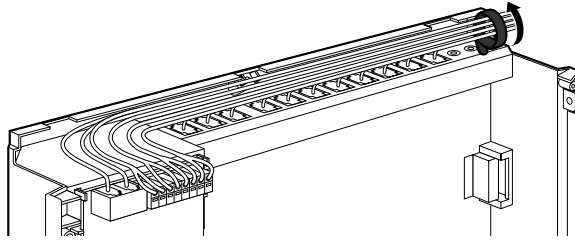

- To remove the rivet, use a screw driver as shown below.

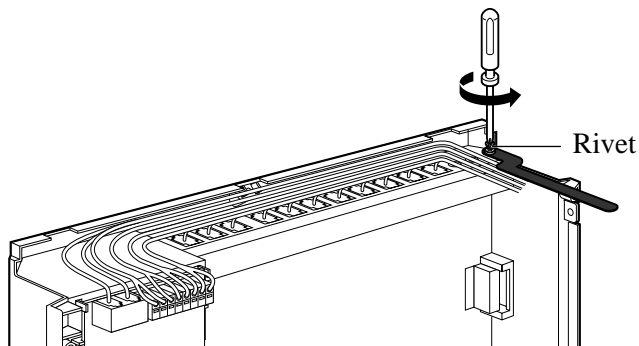

2.20 *Closing the Front Cover*

1. Replace the covers and tighten the screws.
2. Tie together all of the connected cords and attach them to the wall so that the cords cannot be pulled out of the system.

